

GSI®

Ceramic elements italian made

Product Catalogue

N°17
Product
Catalogue

Ceramic Elements. Italian Made.

IT I prodotti presenti in questo volume sono progettati e realizzati in Italia secondo i più alti standard qualitativi, nella tutela dell'ambiente, dei diritti e della salute dei lavoratori.

EN The products in this catalogue are designed and produced in Italy according to the highest quality standards, the environmental protection and of course according to the rights and health of employees.

DE Die Produkte in diesem Katalog wurden in Italien unter Achtung der höchsten Qualitätsanforderungen, des Umweltschutzes und selbstverständlich der Rechte und der Gesundheit der Mitarbeiter entworfen und hergestellt.

Indice generale/General index/Inhaltsverzeichnis

Introduzione/ Introduction/Einleitung

p.4

Plus & Features

p.24

Abaco

p.38

Color Elements

p.60

Introduzione / Introduction / Einleitung p.61
Abaco / Product index / Produktverzeichnis p.62
Disegni tecnici / Technical drawings /
Technische Zeichnungen p.105

Nubes

p.114

Introduzione / Introduction / Einleitung p.115
Abaco / Product index / Produktverzeichnis p.116
Disegni tecnici / Technical drawings /
Technische Zeichnungen p.147

Kube X

p.156

Introduzione / Introduction / Einleitung p.157
Abaco / Product index / Produktverzeichnis p.158
Disegni tecnici / Technical drawings /
Technische Zeichnungen p.193

Norm

p.202

Introduzione / Introduction / Einleitung p.203
Abaco / Product index / Produktverzeichnis p.204
Disegni tecnici / Technical drawings /
Technische Zeichnungen p.229

Pura

p.236

Introduzione / Introduction / Einleitung p.237
Abaco / Product index / Produktverzeichnis p.238
Disegni tecnici / Technical drawings /
Technische Zeichnungen p.275

Modo

p.286

Introduzione / Introduction / Einleitung p.287
Abaco / Product index / Produktverzeichnis p.288
Disegni tecnici / Technical drawings /
Technische Zeichnungen p.297

Classic

p.300

Introduzione / Introduction / Einleitung p.301
Abaco / Product index / Produktverzeichnis p.302
Disegni tecnici / Technical drawings /
Technische Zeichnungen p.323

City

p.330

Introduzione / Introduction / Einleitung p.331
Abaco / Product index / Produktverzeichnis p.332
Disegni tecnici / Technical drawings /
Technische Zeichnungen p.349

Community

p.352

Introduzione / Introduction / Einleitung p.353
Abaco / Product index / Produktverzeichnis p.354
Disegni tecnici / Technical drawings /
Technische Zeichnungen p.369

Shower trays

p.374

Introduzione / Introduction / Einleitung p.375
Abaco / Product index / Produktverzeichnis p.376
Disegni tecnici / Technical drawings /
Technische Zeichnungen p.387

Compstone

p.394

Introduzione / Introduction / Einleitung p.375
Abaco / Product index / Produktverzeichnis p.377
Disegni tecnici / Technical drawings /
Technische Zeichnungen p.397



IT Questo territorio ricco di storia, culla dell'antica civiltà falisca, dominato dalla maestosità solitaria del monte Soratte, ha sempre affascinato poeti, pittori, eremiti. Un paesaggio dolce e aspro: Gallese, Lazio.

EN The local surroundings are rich in history, the cradle of the ancient Faliscan civilization, over which Monte Soratte looms in solitary majesty. It is a region that fascinated poets, painters and hermits with its countryside, both harsh and mild: Gallese, Lazio.

DE Die geschichtsträchtige Gegend des nördlichen Latium, Wiege der antiken Zivilisation der Falisker, beherrscht von der majestätischen Einsamkeit des Monte Soratte, zieht seit jeher Dichter an, Maler, Einsiedler. Eine Landschaft, gleichzeitig süß und rau: Gallese, Lazio.

>
Piatto in ceramica dipinta. Età Etrusca, Museo Nazionale Archeologico, Tarquinia /
Plate in painted ceramic. Etruscan Age, National Archaeological Museum, Tarquinia /
Bemalte Keramikschale. Etruskisch, Archäologisches Museum, Tarquinia



IT **Terra e acqua sono gli elementi che da sempre, dosati e mescolati con sapiente perizia, coesistono armonicamente nella forma dei manufatti.**

Sono millenni che qui, nel nostro territorio, si produce la ceramica: con la terra e l'acqua, suggellate dal fuoco.

EN **Blended and dosed with great skill, water and earth coexist harmonically in the forms of manufactures. Here in our countryside ceramics have been produced for millennia: with earth and water sealed by fire.**

DE **Land und Wasser sind die Elemente, die, wohldosiert und klug gemischt, schon immer harmonisch in den Formen der Manufakturwaren nebeneinander existiert haben. Seit Jahrtausenden wird hier, in unserer Gegend, Keramik hergestellt, werden Land und Wasser durch Feuer versiegelt.**



<
Giovanni Volpato
erma con i ritratti di Anton Raphael Mengs e José Nicolás de Azara, 1785-1798. Collezione Federico Zeri /
herma with portraits by Anton Raphael Mengs and José Nicolás de Azara, 1785-1798. Collection Federico Zeri /
Doppelherme mit den Portraits von Anton Raphael Mengs und José Nicolás de Azara, 1785-1798. Sammlung Federico Zeri



<
Operai del secondo dopoguerra impegnati nel settore ceramico. Civita Castellana, Italia /
Workers engaged in the ceramic industry in the post-world war two period. Civita Castellana, Italy /
Arbeiter der Keramikbranche in der Nachkriegszeit Civita Castellana, Italien



IT La nostra azienda ha sede nell'affascinante campagna laziale, in un paesaggio di straordinaria bellezza che va tutelato. È anche per questo che in GSI tradizione, passione, tecnologia, rispetto delle persone e dell'ambiente, sono valori da sempre naturalmente congiunti.

EN GSI has its headquarters in the enchanting Lazio countryside, a place of outstanding beauty, and one that needs to be protected at all costs. For our company, tradition, passion, technology, respect for people and the environment have always been naturally coinciding values.

DE Unsere Betrieb liegt inmitten der faszinierenden und schützenswerten landschaftlichen Schönheit der Region Latium. Auch deshalb gelten bei GSI Tradition, Einsatzfreude, Technologie und Achtung der Person und der Umwelt als Werte, die seit jeher untrennbar miteinander verbunden sind.

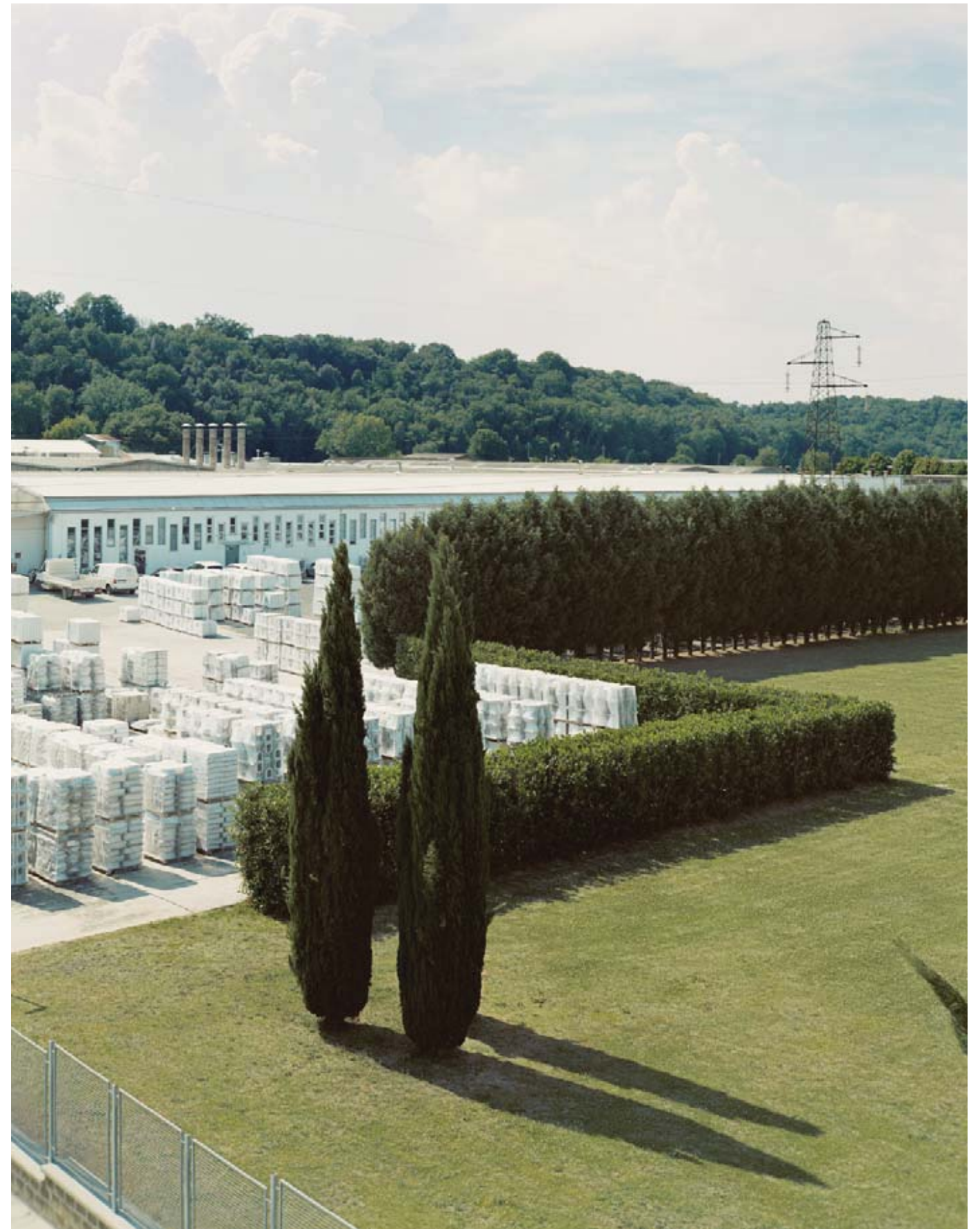

IT Una tradizione resiste nel tempo solo se si è capaci di rinnovarla di continuo. Ecco perché GSI ha deciso di valorizzare le proprie maestranze, mettendo a disposizione della loro competenza e abilità i macchinari più avanzati tra quelli oggi disponibili nel settore ceramico. Andare oltre con la tradizione, con l'unico scopo di realizzare il prodotto migliore possibile.

EN A tradition survives over time only if it is constantly able to renew itself. This is why GSI has decided to make the best use of our staff, entrusting the most advanced equipment available in the ceramics sector to their knowledge and skills. To continue to move forward but with tradition behind us while creating the best possible product.

DE Eine Tradition übersteht die Zeit nur, wenn Sie in der Lage ist, sich beständig zu erneuern. Aus diesem Grund hat GSI beschlossen, nicht nur die Kompetenz und Fähigkeiten der eigenen Belegschaft zu nutzen, sondern ihr auch die modernsten Maschinen zur Verfügung zu stellen, die heute in der Keramikbranche verwendet werden. Die Tradition begleitet uns dabei aus dem alleinigen Grund, ein noch besseres Produkt schaffen zu können.





IT GSI crede nell'innovazione, perché sa che una tecnologia all'avanguardia migliora la qualità del prodotto. Ma la nostra è un'azienda consapevole che senza il fattore umano, vale a dire senza il cuore, la testa, le mani di chi ogni giorno si reca in fabbrica, nessuna tecnologia sarebbe in grado di dare forma e sostanza al progetto.

EN At GSI we believe in innovation because we know that cutting-edge technology will improve our products. But we are aware that without the human factor, heads and hearts and hands of people who show up at the factory every morning, no technology can breathe form and life into a project.

DE Bei GSI setzt man auf Innovation, weil man weiß, dass Spitzentechnologie die Qualität des Produktes zur absoluten Zufriedenheit ihrer Kunden verbessert. Aber wir sind immer noch ein Unternehmen, dass sich sehr wohl darüber bewusst ist, dass ohne den Faktor Mensch, und das heißt, ohne Herz, Kopf, die Hände all derer, die sich jeden Tag ins Werk begeben, keine Technologie in der Lage wäre, einem Projekt wirklich Form und Inhalt zu geben.





IT La percentuale di oggetti GSI che non passa la fase di controllo qualità è piuttosto bassa, risultato di anni di intenso lavoro di innovazione in ciascuna fase produttiva. Ma anche gli scarti rientrano in un ciclo virtuoso di recupero: alcuni sono frantumati per poter essere utilizzati come argilla refrattaria, altri vengono smaltiti nel rispetto della sostenibilità ambientale.

EN The percentage of GSI products that do not get through the inspection phase is actually quite small; this is the result of intense efforts to innovate every phase of the production process. But even discarded pieces reenter a virtuous cycle of recovery: some are broken up to be reused as fire clay, others are glazed to meet the needs of environmental sustainability.

DE Der Prozentanteil der Objekte, die die Qualitätskontrolle nicht passieren, ist bei GSI relativ gering. Das ist das Ergebnis von jahrelanger, harter Arbeit an den Innovationen in jeder Phase der Herstellung. Gleichzeitig aber auch Teil eines positiven Kreislaufs von Rückgewinnung: Einige werden für die Verwendung als Schamotte zerkleinert andere unter Beachtung der ökologischen Nachhaltigkeit verwertet.

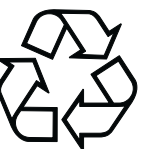



IT Partecipe ed interprete del Made in Italy nel mondo, GSI negli anni ha contribuito alla realizzazione di complessi progetti di interior coniugando funzionalità, design e artigianalità. Attitudini che hanno reso possibile la collaborazione con eccellenze internazionali dell'ospitalità come il Tiara Chateau Hotel di Parigi, il Madinat Jumeirah di Dubai, il Vip Grand di Lisbona, il Yas Marina di Abu Dhabi, l'Adler Lodge Ritten, l'Adler Hotel Alpe di Siusi, il Quellenhof Luxury Resort Lazise, il Quellenhof Luxury Resort Sudtirolo, il Falkensteiner Hotel & Spa di Jesolo, Rocco Forte Hotel Villa Igiea e molti altri.

EN Participant and interpreter of Made in Italy throughout the world, over the years GSI has contributed to the realization of complex projects of interior settings that combine functionality, design and craftsmanship. These attitudes have led to relationships with global leaders in the hospitality industry like the Tiara Chateau Hotel in Paris, the Madinat Jumeirah in Dubai, the Vip Grand in Lisbon, the Yas Marina in Abu Dhabi, the Adler Lodge Ritten, the Adler Hotel Alpe di Siusi, the Quellenhof Luxury Resort Lazise, the Quellenhof Luxury Resort Sudtirolo, the Falkensteiner Hotel & Spa in Jesolo, Rocco Forte Hotel Villa Igiea and many others.

DE Als Protagonist und Interpret des internationalen Made in Italy hat GSI in den Jahren bei der Realisierung vieler komplexer Innenrichtungsprojekte mitgewirkt und wusste dabei stets Funktionalität, Design und Kunstfertigkeit zu vereinigen. Qualitäten, die die Zusammenarbeit mit internationalen Exzellenzen im Bereich Hospitality wie dem Tiara Chateau Hotel von Paris, dem Madinat Jumeirah in Dubai, dem Vip Grand von Lissabon, dem Yas Marina von Abu Dhabi, der Adler Lodge Ritten und dem Adler Hotel Alpe in Seis, dem Quellenhof Luxury Resort Lazise, dem Quellenhof Luxury Resort Südtirol, dem Falkensteiner Hotel & Spa in Jesolo, Rocco Forte Hotel Villa Igiea und vielen weiteren großen Häusern ermöglicht haben.



IT GSI arricchisce la propria famiglia di prodotti con la gamma Color Elements: otto tinte opache ispirate alla natura accompagnano selezionati prodotti delle collezioni Nubes, Pura e Kube X. I sanitari della collezione presentano la speciale finitura Dual Glaze+, che combina la smaltatura opaca all'esterno con quella lucida Extraglaze® Antibacterial nelle parti idrauliche a contatto con l'acqua, evitando macchie ed antigenici residui calcarei.

EN GSI has enriched its family of products with Color Elements: eight matt shades inspired by nature accompany select products in the Nubes, Pura and Kube X collections. This collection's sanitaryware has the special Dual Glaze+ finish, combining an external matt glaze with a glossy Extraglaze® Antibacterial for hydraulic components staying in contact with water. This helps to avoid stains and unhygienic lime deposits.

DE GSI bereichert die firmeneigene Produktfamilie mit der Color Elements Palette: acht matte Farben, die sich an der Natur inspirieren begleiten ausgewählte Produkte der Kollektionen Nubes, Pura und Kube X. Die Sanitärobjekte der Kollektion bieten das ganz besondere Finish Dual Glaze+, bei dem die matte Glasur der Außenseite mit der Glanzglasur Extraglaze® Antibacterial an den in Kontakt mit Wasser befindlichen Teilen kombiniert wird, wodurch Flecken und unhygienische Kalkablagerungen vermieden werden.

IT Un buon progetto può definirsi tale solo se estetica e design sono supportati da igiene, sicurezza, durevolezza e affidabilità. Per garantire tutti questi aspetti GSI Ceramica ha sviluppato una serie di innovazioni tecnologiche da un elevato standard funzionale: numerosi Plus brevettati, in dotazione sulla quasi totalità delle collezioni disponibili.

EN A good project can be considered as successful only if aesthetics and design are backed up by the right levels of hygiene, safety, durability and reliability. To ensure compliance with quality levels regarding these aspects, GSI Ceramica has developed a number of technological innovations and quality patented products, which have been added to practically all its collections.

DE Ein gutes Projekt kann nur dann als solches definiert werden, wenn Ästhetik und Design durch Hygiene, Sicherheit, Dauerhaftigkeit und Zuverlässigkeit gestützt werden. Zur Gewährleistung all dieser Aspekte hat GSI Ceramica eine Reihe technologischer Innovationen ausgehend von einem hohen Funktionsstandard entwickelt: zahlreiche patentierte Plus-Funktionen, mit denen fast alle erhältlichen Kollektionen ausgerüstet sind.

1. Extraglaze® Antibacterial
2. Swirlflush®
3. Dual Glaze+
4. Save Water
5. Soft Close
6. Quick Release
7. Silent
8. 400 Kg Tested

Plus & Features

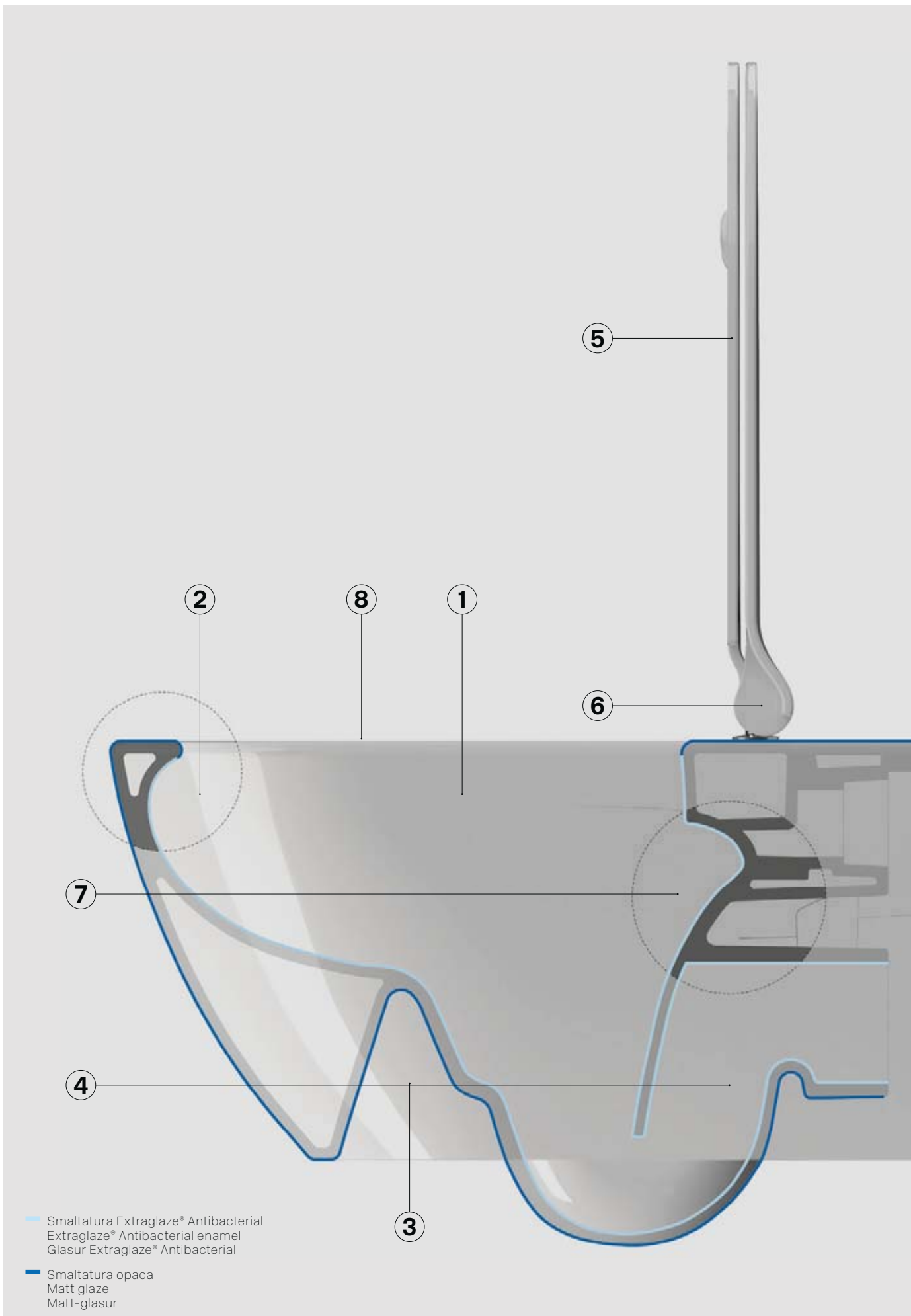

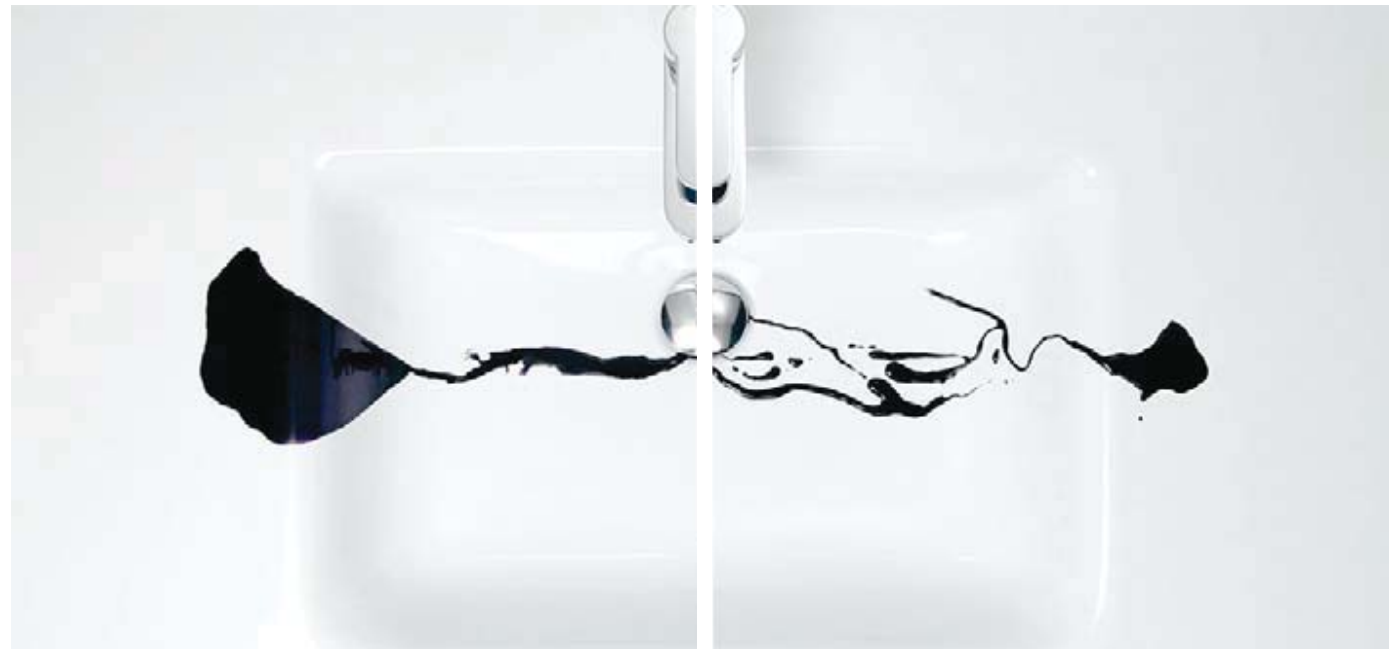

Smalto tradizionale
Traditional glaze
Traditionelle Schmelz

Extraglaze®
Antibacterial

Smalto tradizionale
Traditional glaze
Traditionelle Schmelz

Ceramica
Ceramics
Keramik

Extraglaze®
Antibacterial

Ceramica
Ceramics
Keramik

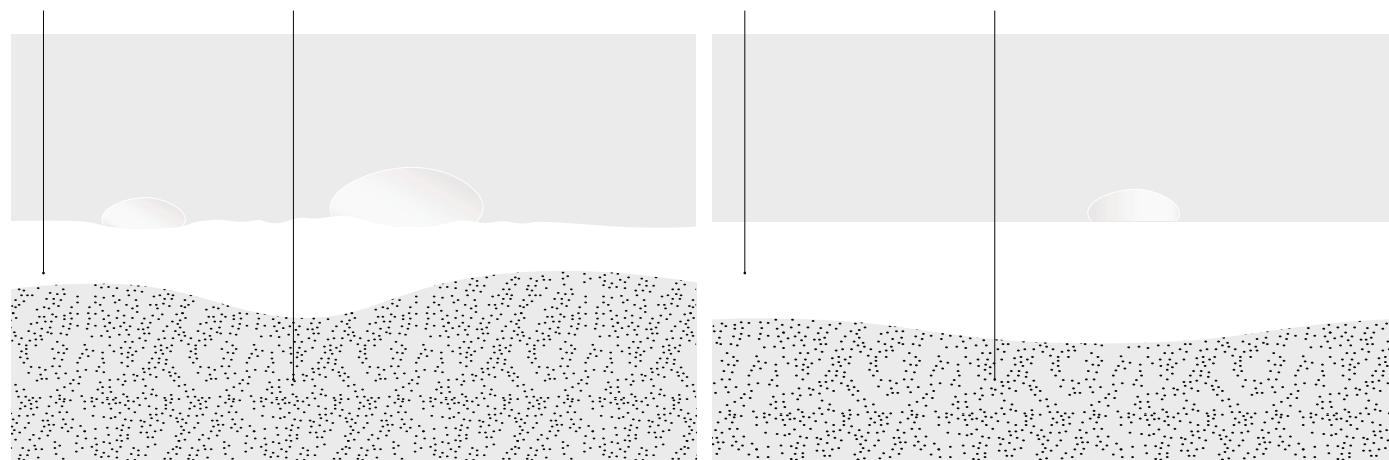

1. Extraglaze® Antibacterial

IT GSI implementa igiene e brillantezza con lo smalto Extraglaze® Antibacterial, la speciale formula arricchita con ioni di Argento e Titanio che assicura un'azione antibatterica certificata ISO 22196. I prodotti trattati con Extraglaze® Antibacterial sono più resistenti agli agenti chimici, e grazie all'estrema levigatezza e brillantezza, sono protetti da calcare e batteri e rimangono pulite più a lungo.

EN GSI provides hygiene and shininess with the Extraglaze® Antibacterial glaze, the special formula enriched with silver and titanium ions that ensures ISO 22196 certified antibacterial action. The products treated with the Extraglaze® Antibacterial are more resistant to chemicals, and thanks to the extreme smoothness and brightness, they are protected from bacteria and limestone and stay clean longer.

DE GSI bietet Hygiene und Glanz mit der Extraglaze® Antibacterial - Glasur, der speziellen Formel, die mit Silber- und Titan Ionen angereichert ist und eine nach ISO 22196 zertifizierte antibakterielle Wirkung gewährleistet. Auf diese Weise ist die Glasur ein Bestandteil der Keramik und dauerhaft wirksam. Die mit Extraglaze® Antibacterial -Glasur behandelten Produkte sind resistenter gegen Chemikalien und dank der glatten.



IT Igiene totale. Testato e certificato per una protezione antibatterica assicurata al 99,99%.

EN Total Hygiene. Tested and certified for guaranteed 99.99% antibacterial action.

DE Maximale Hygiene. Geprüft und zertifiziert für eine garantierte antibakterielle Wirkung von 99,99%.



IT Maggiore Brillantezza. Protegge dal calcare e conserva la brillantezza originaria della ceramica più a lungo.

EN Greater Shininess. Protects from limescale and preserves the ceramic's original shininess for much longer.

DE Größerer Glanz. Schützt vor Kalkablagerungen und erhält den ursprünglichen Glanz der Keramik.



IT Pulizia rapida. La speciale azione antibatterica consente una pulizia più facile e rapida per l'igiene ordinaria.

EN Quick Cleaning. Special antibacterial action makes cleaning easier and faster for normal hygiene.

DE Schnelle Reinigung. Eine spezielle antibakterielle Wirkung erleichtert und beschleunigt die Reinigung für eine maximale Hygiene.



IT Rispetto per l'ambiente. La levigatezza delle superfici rende necessaria una minor quantità di prodotti per la pulizia.

EN Respect for the Environment. Surface smoothness means a smaller quantity of the product is needed for cleaning.

DE Respekt für die Umwelt und Nachhaltigkeit. Oberflächenglätte bedeutet, dass eine geringere Menge an Reinigungsmittel benötigt wird.



2. Swirlflush®

IT Silenzioso, igienico, pulito. La caratteristica più evidente del rivoluzionario ed esclusivo sistema brevettato Swirlflush® è l'assenza della tradizionale bordatura, la brida, all'interno della quale, in un normale wc, circola l'acqua al momento dello scarico. La conformazione del sistema di scarico Swirlflush® l'unico brevettato con un solo foro direziona l'acqua sulle superfici ceramiche in maniera uniforme assicurando una pulizia ottimale migliorando le performance di scarico e riducendo al minimo il rumore (solo 64 db invece dei 72 di un wc standard).

EN Silent, hygienic, clean. The main characteristic of the revolutionary and exclusive Swirlflush® patented system is the absence of the traditional edge, the rim inside which, in a standard WC water circulates when flushing. The special shape of the Swirlflush® flushing system, the only one patented with a single hole, steers flush water evenly on ceramic surfaces, ensuring perfect cleansing, better draining, and minimising noise (only 64 db instead of 72 of a standard wc).

DE Leise, hygienisch, sauber. Das offensichtlichste Merkmal des revolutionären Patentsystems Swirlflush® ist das Fehlen des traditionellen Spülrands, in dessen Inneren bei einem normalen WC das Wasser beim Spülvorgang strömt. Die Gestaltung des Swirlflush® das einzige WC mit einem Wasserausgang Spülsystems richtet den Wasserstrahl gleichmäßig auf die Keramikoberflächen und sichert dadurch optimale Reinigung und die Verbesserung der Spüleistung bei gleichzeitiger Dämpfung des Spülgeräusches (nur 64 dB gegenüber den 72 einer Standardtoilette).

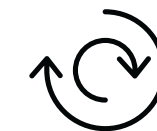

IT Silenziosità. Il nuovo sistema di risciacquo garantisce estrema silenziosità durante la fase di scarico.

EN Noise. The new rinse system minimizes noise during flushing.

DE Leise. Das neue Spülsystem sorgt für einen besonders leisen Spülvorgang ohne lästige Geräusche.



IT Pulizia rapida. Il design Swirlflush®, non presentando parti nascoste, facilita le normali operazioni di pulizia del sanitario.

EN Quick Cleaning. The Swirlflush® design has no hidden parts, and thus routine cleaning operations are made easier

DE Schnelle Reinigung. Das Design von Swirlflush® keine verborgenen oder schwer erreichbaren Teile beinhaltet, werden ferner die normalen Reinigungsvorgänge des WCs erleichtert.



IT Igiene totale. L'assenza della brida, la tradizionale bordatura dove in un normale wc scorre l'acqua, evita la formazione di calcare e il deposito di batteri.

EN Total Hygiene. This WC does not have a rim, the edge beneath which water flows in a traditional normal lavatory. This prevents the formation of limescale and the depositing of bacteria.

DE Maximale Hygiene. Das Fehlen des traditionellen Spülrands, unter dem für gewöhnlich das Wasser ins WC strömt, vermeidet die Ansammlung von Kalkablagerungen und Bakterien.



IT Rispetto per l'ambiente. La conformazione delle parti ceramiche a contatto con l'acqua consente le funzioni di scarico con un ridotto consumo di acqua.

EN Respect for the Environment. This lavatory flushes using less water thanks to the particular shape of ceramic parts making contact with water.

DE Respekt für die Umwelt und Nachhaltigkeit. Die Gestaltung der in Wasserkontakt stehenden Keramikteile ermöglicht eine Spülfunktion mit reduziertem Wasserverbrauch.



3. Dual Glaze+

IT Estetica e igiene non sono antagonisti, al contrario: il trattamento Dual Glaze+, studiato per un'igiene ottimale, combina la raffinata smaltatura opaca dell'esterno con quella interna lucida Extraglaze® Antibacterial nelle parti idrauliche a contatto con l'acqua. Si evitano così macchie ed antigienici residui calcarei, frequenti conseguenze della tipica porosità del prodotto in ceramica con un'unica finitura opaca.

EN Aesthetics and hygiene needn't exclude each other, on the contrary: the Dual Glaze+ treatment, specially designed for total hygiene, combines the elegant opaque finishing on the outside with the shiny, easily washable Extraglaze® Antibacterial glazing on the inside where parts come into contact with water. DualGlaze+ is designed to prevent unhygienic lime deposits, a frequent phenomenon due to the porous nature of ceramic products having a single matt finish.

DE Ästhetik und Hygiene schließen einander nicht aus, im Gegenteil: die Dual Glaze+ Behandlung, die zur Optimierung der Hygiene entwickelt wurde, kombiniert die raffinierte matte Glasur der Außenseite mit der Glanzglasur Extraglaze® Antibacterial an den in Kontakt mit Wasser befindlichen Teilen. Auf diese Weise werden Fleckenbildung und unhygienische Kalkablagerungen vermieden, die oftmals Folge jener typischen Porosität von Keramikprodukten mit einheitlich matt glasierter Oberfläche sind.

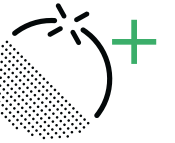

IT Igiene totale. Testato e certificato per una protezione antibatterica assicurata al 99,99%.

EN Total Hygiene. Tested and certified for guaranteed 99.99% antibacterial action.

DE Maximale Hygiene. Geprüft und zertifiziert für eine garantierte antibakterielle Wirkung von 99,99%.



IT Pulizia rapida. La speciale azione antibatterica consente una pulizia più facile e rapida per l'igiene ordinaria.

EN Quick Cleaning. Special antibacterial action makes cleaning easier and faster for normal hygiene.

DE Schnelle Reinigung. Eine spezielle antibakterielle Wirkung erleichtert und beschleunigt die Reinigung für eine maximale Hygiene.



IT Maggiore Brillantezza. Protegge dal calcare e conserva la brillantezza originaria della ceramica più a lungo.

EN Greater Shininess. Protects from limescale and preserves the ceramic's original shininess for much longer.

DE Größerer Glanz. Schützt vor Kalkablagerungen und erhält den ursprünglichen Glanz der Keramik.



IT Rispetto per l'ambiente. La levigatezza delle superfici rende necessaria una minor quantità di prodotti per la pulizia nonché una riduzione del consumo di acqua in fase di scarico.

EN Respect for the Environment. Fewer cleaning products are needed due to the smooth surfaces, and less water is consumed when flushing.

DE Respekt für die Umwelt und Nachhaltigkeit. Die Glätte der Oberflächen sorgt für einen verringerten Bedarf an Reinigungsmitteln sowie für eine Senkung des Wasserverbrauchs beim Spülen.



4. Save Water

IT Con la volontà di preservare il bene più prezioso che ci appartiene, GSI progetta i sanitari integrando lo speciale sistema di scarico Save Water, ottenuto grazie alla particolare conformazione delle parti ceramiche a contatto con l'acqua. Il sistema Save Water consente di eseguire le funzioni di scarico con soli 4,5 lt di acqua.

EN Aiming to preserve the most valuable asset that we have, GSI designs its sanitary ware with the special flush system Save Water, thanks to the special shape of the ceramic parts directly in contact with water. The Save Water system allows you to flush with just 4,5 litres of water.

DE Zum Schutz der wertvollsten Ressource des Menschen stattet GSI die gesamte Sanitärkeramik mit dem besonderen Spülsystem Save Water aus. Das vom GSI-Designerteam entworfene System ist das Ergebnis einer kontinuierlichen technischen Entwicklung und beruht auf der besonderen Form der Keramikteile, die in direktem Kontakt mit dem Wasser sind. Dank des Save Water-Systems werden beim Spülen nur 4,5 Liter verbraucht.



9

I litri di acqua generalmente utilizzati.
Liters of water generally used.
Allgemein verbrauchte Liter Wasser.



6

I litri richiesti dalle normative europee.
Liters required by European standards.
Von den europäischen Richtlinien vorgeschriebene Liter Wasser.



4,5

I litri di acqua utilizzati da un wc GSI.
Liters of water used by a GSI wc.
Von einem GSI-WC verbrauchte Liter.





5. Soft Close

IT Il sistema Soft Close predispose il copriwater per una chiusura rallentata, questo consentirà di evitare cadute accidentali e chiusure del copriwater troppo violente. I copriwater GSI sono realizzati con resine registrate FDA e EPA in grado di ostacolare la crescita di germi e batteri grazie alle proprietà degli ioni d'argento.

EN The Soft Close system predisposes the seat and cover for a slow closing, preventing accidental falls and violent closures of the seat and cover. GSI's toilet seats are made with FDA- and EPA-registered resins that can prevent the spread of germs and bacteria thanks to the action of silver ions.

DE Das Soft Close System sorgt für gebremstes Schließen des Toilettendeckels, wodurch versehentliches Herunterfallen und schlagartiges Schließen des Deckels vermieden werden. Die WC-Sitze von GSI werden aus Kunstharzen gefertigt, die bei den amerikanischen Behörden FDA und EPA registriert und in der Lage sind, das Wachstum von Keimen und Bakterien durch die Wirkung von Silberionen zu hemmen.





6. Quick Release

IT Il sistema Quick Release permette di estrarre il copriwater in maniera semplice e senza l'impiego di utensili in modo da eseguire le operazioni di pulizia anche nelle superfici generalmente difficili da raggiungere.

EN The Quick Release system, which it allows to pull out the seat and cover in a simple way and without the use of any tool. This will make it possible to clean the toilet seat and even the wc in areas that are usually difficult to reach.

DE GSI führt einen neuen WC-Sitz mit einem innovativen Installationssystem ein. Das neue Quick Release System unterscheidet sich von anderen durch die Einfachheit, mit der der WC-Sitz ohne den Einsatz von Werkzeugen abgenommen werden kann.



Nubes

120×50
9625111
p.124



120×50
9624111
p.126



100×50
9651111
p.126



100×50
9623111
p.126



80×50
9622111
p.128



60×50*
9631111
p.128



70×40
9687111
p.130



60×40
9683111
p.130



50×40*
9682111
p.130



40×32
9684111
p.132
p.82 →



36×28
9638111
p.132



50×25**
9637011
p.134



40×23**
9636011
p.134



60×38
903611
p.136
p.84 →



50×38
903711
p.136
p.84 →



38×38
903811
p.136
p.84 →



Ø40
903911
p.138
p.84 →



Kube X

120×47
9425111
p.164



120×47
9424111
p.164



100×47
9423111
p.166



80×47
9422111
p.166



60×47**
9431111
p.166



50×47**
9430111
p.166



120×47
9452111
p.168



100×47
9451111
p.168



80×47
9456111
p.170



80×47
9457111
p.170



70×37
9455111
p.172



60×37
9454111
p.172



50×37
9447111
p.172



45×35**
9485111
p.172



50×25
9486011
p.174
p.86 →



40×23
9484011
p.174
p.86 →



*Disponibile anche in Bianco opaco /
Also available Bianco opaco /
Erhältlich in Bianco opaco

**Disponibile anche in Bianco opaco e Ardesia /
Also available Bianco opaco and Ardesia /
Erhältlich in Bianco opaco and Ardesia

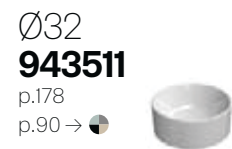
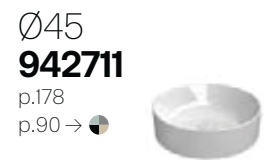

Norm



Pura

120×50
8845111
p.246



122×46
8840111
p.248



102×52
8825111
p.250



100×50
8844111
p.246



102×46
8833111
p.248



82×49
8826111
p.250



80×50
8843111
p.246



82×46
8838111
p.248



62×48
8827111
p.250



60×50
8836111
p.246



62×46
8839111
p.248



52×44
8830111
p.250



60×42
884211
p.252
p.92 →



60×37
883411
p.254
p.92 →



50×35
886011
p.254
p.92 →



Ø42
885111
p.256
p.94 →



Ø42
885511
p.256
p.94 →



Ø42 h22
885211
p.256
p.94 →



Ø32
885411
p.256
p.94 →



60×38
883711
p.258
p.96 →



50×38
884711
p.258
p.96 →



38×38
885011
p.258
p.96 →



Ø40
884611
p.258
p.96 →



55×38
724311
p.260



50×35
724711
p.260



Classic

125×54
8725111
p.310



105×54
8723111
p.310



90×50
8788111
p.312



75×50
8787111
p.312



60×46
8731111
p.312



55×38
724311
p.314



50×35
724711
p.314



City

64×48
9131111
p.336



58×45
9130111
p.336



61×52
MASIAN111
p.338



57×47
MALISEON111
p.338



57×42
MVULCN11
p.340



Community

70×55
7633011
p.358



60×55
7635011
p.358



Appoggio/ Countertop/ Aufsatzmontage

Nubes

60×38
903611

p.136
p.84 →



50×38
903711

p.136
p.84 →



38×38
903811

p.136
p.84 →



Ø40
903911

p.138
p.84 →



Kube X

60×37
945311

p.176
p.88 →



50×37
942911

p.176
p.88 →



60×37
945811

p.178
p.90 →



Ø45
942711

p.178
p.90 →



Ø40
942611

p.178
p.90 →



Ø32
943511

p.178
p.90 →



50×25
9486011

p.174
p.86 →



40×23
9484011

p.174
p.86 →



Pura

60×42
884211

p.252
p.92 →



60×37
883411

p.254
p.92 →



50×35
886011

p.254
p.92 →



Ø42
885111

p.256
p.94 →



Ø42
885511

p.256
p.94 →



Ø42 h22
885211

p.256
p.94 →



Ø32
885411

p.256
p.94 →



**Incasso/
Built-in/
Einbaumontage**

Nubes

50×25*
9637011
p.134



40×23*
9636011
p.134



Kube X

70×46
9437111
p.180



58×40
9433111
p.180



80×37
895411
p.184



60×37
895311
p.184



Pura

60×38
883711
p.258
p.96 →



50×38
884711
p.258
p.96 →



38×38
885011
p.258
p.96 →



Ø40
884611
p.258
p.96 →



City

61×52
MASIAN111
p.338



57×47
MALISEON111
p.338



**Sottopiano/
Under-counter/
Unterbaumontage**

Pura

55×38
724311
p.260



50×35
724711
p.260



City

57×42
MVULCN11
p.340



**Semincasso/
Semi-recessed/
Halbeinbau**

Kube X

55×47
9434111
p.182



*Disponibile anche in Bianco opaco e Ardesia/
Also available Bianco opaco and Ardesia/
Erhältlich in Bianco opaco und Ardesia

Nubes

55×35/F*
961511
9665111
 p.140



52×35/F*
961011
9662111
 p.142



50×35/F*
961611
9664111
 p.140



Kube X

55×36/F**
941511
9465111
 p.186



50×36/F**
941611
9464111
 p.186



46×36/F
941811
 p.188



Norm

55×36/F**
941011
9462111
 p.190



55×36/F
861511
8665111
 p.222



50×36/F
861611
8664111
 p.222



55×36
861411
8662111
 p.224



68×36
861711
 p.226



*Disponibile anche in Bianco opaco /
 Also available Bianco opaco /
 Erhältlich in Bianco opaco

**Disponibile anche in Bianco opaco e Ardesia /
 Also available Bianco opaco and Ardesia /
 Erhältlich in Bianco opaco and Ardesia

Pura

55x36/F
881511
8865111
p.262
p.98 →



50x36/F
881611
8864111
p.262
p.100 →



55x36/F
881011
8862111
p.268
p.102 →



50x36/F
882011
8869111
p.268



68x38
881711
p.272



55x36/R
882111
8865111
p.264



55x36/R
880911
8862111
p.270



55x35/F
881111
8861111
p.266



Modo

52x37/F
981611
9864111
p.292



52x37/F
981011
9862111
p.294



Classic

55x37
871211
8765111
p.316



54x37
871011
871111
8762111
p.318



70x37
871711
p.320



City

52x35/F
911511
9164111
p.342



52x35/F
911611
9164111
p.344



Community

70x36/F
761511
p.360



Community

35×31/R*
909711
 p.362



35×31/R*
909811
 p.362



30×30/R*
769511
 p.364



30×30/R*
769611
 p.364



39×31
769711
 p.366



39×31
769811
 p.366



36×25
889711
 p.366



*Disponibile anche in Bianco opaco, Cenere e Ardesia /
 Also available Bianco opaco, Cenere and Ardesia /
 Erhältlich in Bianco opaco Cenere and Ardesia

Nubes

185×90
VASAND90
 p.144



180×80**
VASAND80
 p.144



**Disponibile anche in Bianco opaco /
 Also available Bianco opaco /
 Erhältlich in Bianco opaco

120x90
439511
p.380



120x80
439811
p.382



120x70
439911
p.384

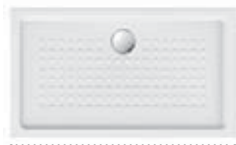

100x90
439211
p.380



100x80
438511
p.382



100x70
438911
p.384



90x90
439411
p.380



80x80
438411
p.382



90x72
438811
p.384



.....
Lato non smaltato/
Not glazed side/
Nicht Glasierte seite

210→120x120
p.394



210→110x110
p.394



210→100x100
p.394

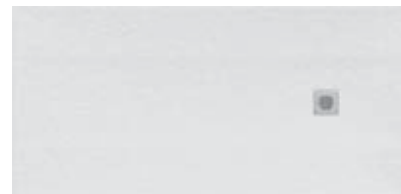

210→90x90
p.394



210→80x80
p.394



210→70x70
p.394

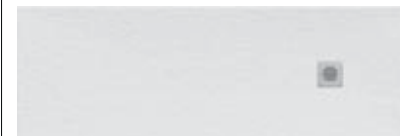



IT Matericità seducente e carattere distintivo, otto tinte matt ispirate alla natura accompagnano selezionati prodotti delle collezioni Nubes, Pura e Kube X. I wc presentano la speciale finitura Dual Glaze+, che combina la smaltatura opaca all'esterno del sanitario con quella lucida Extraglaze® Antibacterial nelle parti idrauliche a contatto con l'acqua, per garantire con un tratto esclusivo la massima igiene.

EN Seductive in their materiality and distinctive character, eight matt shades inspired by nature accompany select products in the Nubes, Pura and Kube X collections. The Wc's come with the special Dual Glaze+ finishing that combines an opaque glaze on the outside of the sanitary fixture with the shiny Extraglaze® Antibacterial glazing in the hydraulic sections in contact with water, an exclusive feature that guarantees maximum hygiene.

DE Verführerische plastische Note und große Persönlichkeit, acht der Natur entlehnte Matt-Töne prägen ausgewählte Produkte der Kollektionen Nubes, Pura und Kube X. Die WCs präsentieren sich in der Spezialausführung Dual Glaze+, d.h. sie sind an den Außenteilen mit matter Glasierung versehen, während die im Kontakt mit Wasser stehenden Teile in glänzender Extraglaze® Antibacterial-Glasur gehalten sind, um mit exklusiver Note für maximale Hygiene zu sorgen.

Color elements

Nubes

40×32
9684105
 p.82



60×38
903605
 p.84



50×38
903705
 p.84



38×38
903805
 p.84



Ø40
903905
 p.84



Kube X

50×25
9486005
 p.86



40×23
9484005
 p.86



60×37
945305
 p.88



50×37
942905
 p.88



60×37
945805
 p.90



Ø45
942705
 p.90



Ø40
942605
 p.90



Ø32
943505
 p.90



Pura

60×42
884205
 p.92



60×37
883405
 p.92



50×35
886005
 p.92



Ø42
885105
 p.94



Ø42
885505
 p.94



Ø42 h22
885205
 p.94



Ø32
885405
 p.94



60×38
883705
 p.96



50×38
884705
 p.96



38×38
885005
 p.96



Ø40
884605
 p.96



Pura

55x36/F
881505
8865105
p.98



55x36/F
881005
8862105
p.102



50x36/F
881605
8864105
p.100





Pura 60x38 Agave
Lavabo / Washbasin / Waschbecken

Compstone Agave
Piatto doccia / Shower tray / Duschwanne

Pura 55x36/F Agave
Wc e bidet / Wc and bidet / Wc und Bidet



Pura Ø42 h22 Ardesia
 Lavabo / Washbasin / Waschbecken

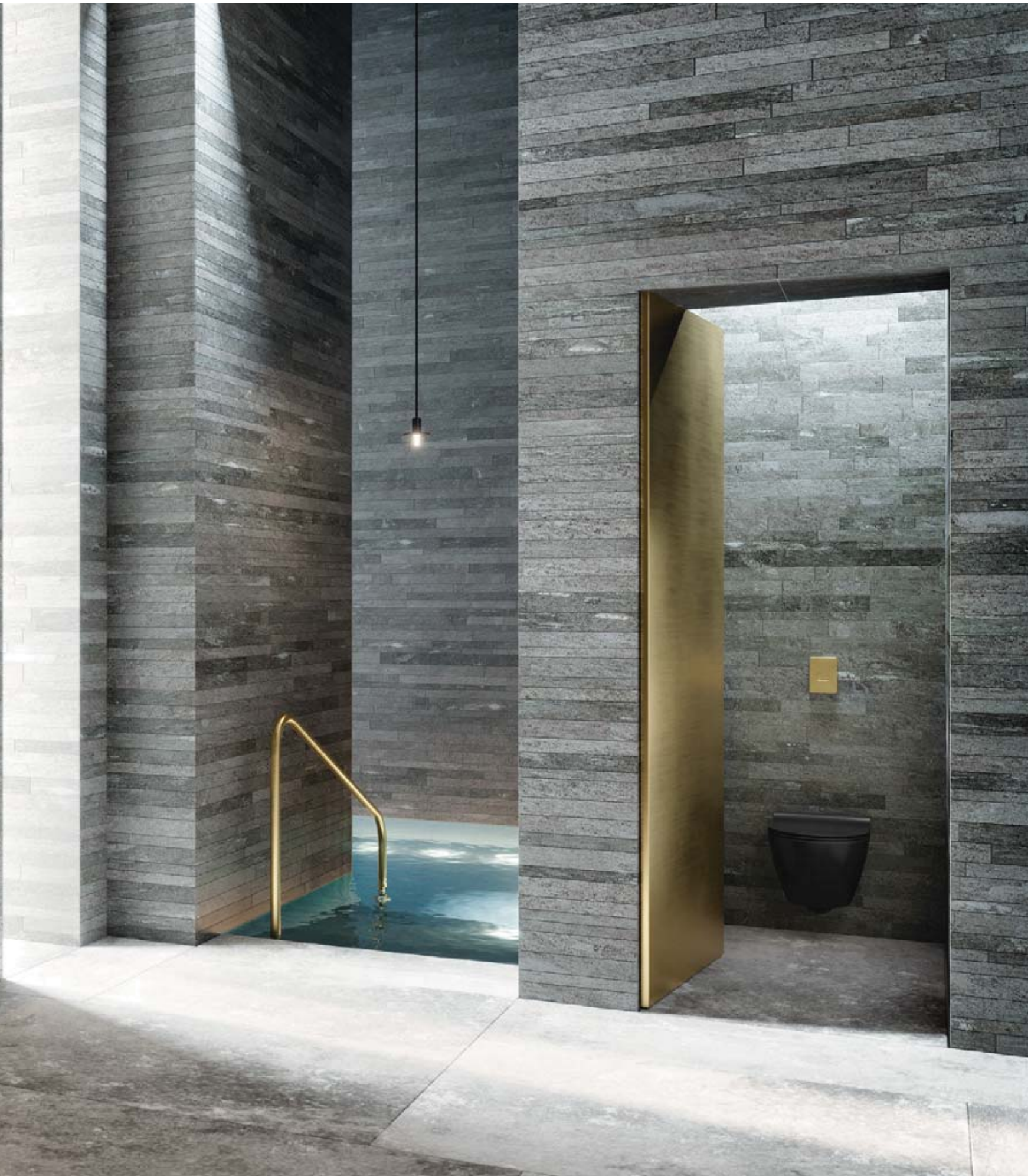

Pura 55×36/F Ardesia
 Wc



Pura Ø40 Bianco opaco
Lavabo / Washbasin / Waschbecken



Pura 60×42 Bistro
Lavabo / Washbasin / Waschbecken

Pura 50×36/F Bistro
Wc



Pura Ø42 Cenere
 Lavabo / Washbasin / Waschbecken

Pura 50×36/F Cenere
 Wc e bidet / Wc and bidet / Wc und Bidet



Pura 55x36/F Creta
 Wc e bidet / Wc and bidet / Wc und Bidet

Compstone Creta
 Piatto doccia / Shower tray / Duschwanne

Nubes 60x38 Creta
 Lavabo / Washbasin / Waschbecken

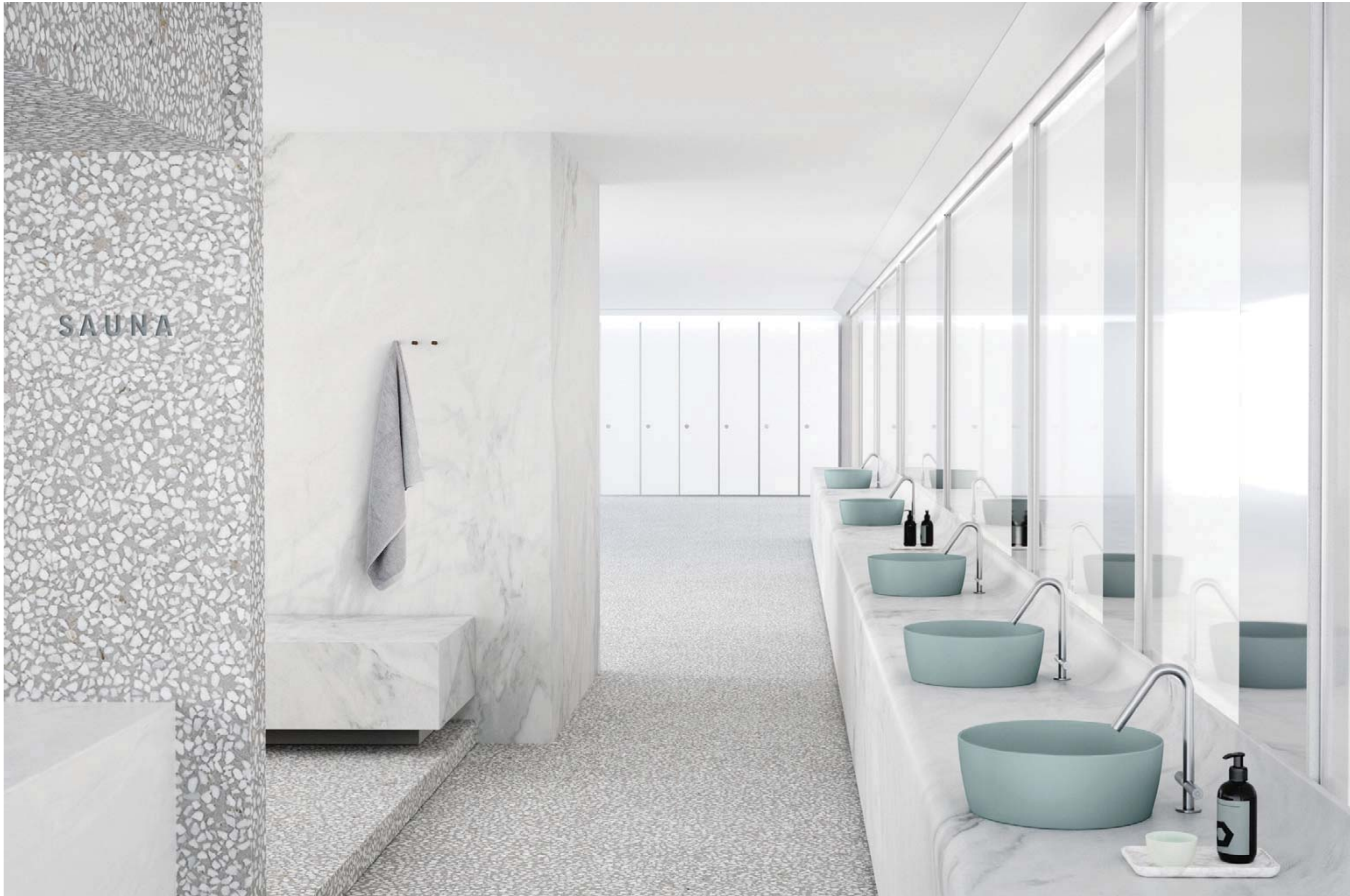

SAUNA

Nubes Ø40 Ghiaccio
Lavabo / Washbasin / Waschbecken



Compstone Tortora
Piatto doccia / Shower tray / Duschwanne

Pura 55×36/F Tortora
Wc e bidet / Wc and bidet / Wc und Bidet

Pura 60×37 Tortora
Lavabo / Washbasin / Waschbecken

82 Lavabo con foro troppopieno e monoforo per rubinetteria. Installazione a sospensione o ad incasso / Washbasin with overflow and one taphole for tap fittings. Wall-hung or built-in installation / Waschtisch mit Überlauf und Einlocharmatur. Für Wand- oder Einbaumontage

Opzione colore/Color options/Faberoption

- | | |
|-------------------------------------|--------------------------------|
| <input type="radio"/> Bianco lucido | <input type="radio"/> Creta |
| <input type="radio"/> Bianco opaco | <input type="radio"/> Ghiaccio |
| <input type="radio"/> Agave | <input type="radio"/> Tortora |
| <input type="radio"/> Ardesia | |
| <input type="radio"/> Bistro | |
| <input type="radio"/> Cenere | |

Installazione/Installation/Installation

- | |
|--|
| <input type="checkbox"/> Sospensione/Wall-hung/Wanshängend |
| <input type="checkbox"/> Incasso/Built-in/Einbaumontage |

40x32
9684105



Nubes 40x32 Tortora
Lavabo / Washbasin / Waschbecken



Nubes 38x38 Tortora
Lavabo / Washbasin / Waschbecken

Lavabo senza foro troppopieno predisposto per rubinetteria a parete o su piano.
 Installazione ad appoggio /
 Washbasin without overflow designed for wall or countertop tap fittings.
 Countertop installation /
 Waschtisch ohne Überlauf, geeignet für Wand- oder Standarmaturen.
 Aufgesetzte Installation

Opzione colore / Color options / Faberoption

- Bianco lucido ● Creta
- Bianco opaco ● Ghiaccio
- Agave ● Tortora
- Ardesia
- Bistro
- Cenere

Installazione / Installation / Installation

- ☐ Appoggio / Countertop / Aufsatzwaschbecken

60x38
903605



50x38
903705



38x38
903805



Ø40
903905



Nubes Ø40 Ghiaccio
Lavabo / Washbasin / Waschbecken

Lavabo senza foro troppopieno predisposto per rubinetteria monoforo laterale. Installazione sospesa (con fori laterali posteriori per l'aggancio a parete) o ad appoggio (con tutti i lati a vista smaltati) / Washbasin without overflow, designed for single lateral taphole. Installation wall-hung (with rear lateral holes for wall fitting) or countertop (with all visible surfaces glazed) / Waschtisch ohne Überlauf, geeignet für seitliche Hahnlochbefestigung. Wandinstallation (mit seitlichen hinten angebrachten Öffnungen für Wandaufhängung) oder Aufsatzinstallation (alle Sichtseiten glasiert)

Opzione colore/Color options/Faberoption

- | | |
|-------------------------------------|--------------------------------|
| <input type="radio"/> Bianco lucido | <input type="radio"/> Cenere |
| <input type="radio"/> Bianco opaco | <input type="radio"/> Creta |
| <input type="radio"/> Agave | <input type="radio"/> Ghiaccio |
| <input type="radio"/> Ardesia | <input type="radio"/> Tortora |
| <input type="radio"/> Bistro | |

Installazione/Installation/Installation

- Sospensione/Wall-hung/Wanshängend
- Appoggio/Countertop/Aufsatzwaschbecken

50×25
9486005



40×23
9484005



Kube X 40×23 Bianco opaco
Lavabo / Washbasin / Waschbecken

Pura 50×36/F Bianco opaco
Wc

88 Lavabo senza foro troppopieno predisposto per rubinetteria a parete o su piano.
Installazione ad appoggio /
Washbasin without overflow designed for wall or countertop tap fittings.
Installation countertop /
Waschtisch ohne Überlauf, geeignet für Wand- oder Standarmaturen.
Aufgesetzte Installation

Opzione colore / Color options / Faberoption

- | | |
|--|--------------------------------|
| <input type="radio"/> Bianco lucido | <input type="radio"/> Creta |
| <input type="radio"/> Bianco opaco | <input type="radio"/> Ghiaccio |
| <input type="radio"/> Agave | <input type="radio"/> Tortora |
| <input checked="" type="radio"/> Ardesia | |
| <input type="radio"/> Bistro | |
| <input type="radio"/> Cenere | |

Installazione / Installation / Installation

 Appoggio / Countertop / Aufsatzwaschbecken

60x37
945305



50x37
942905



Kube X 60x37 Ardesia
Lavabo / Washbasin / Waschbecken

90 Lavabo senza foro troppopieno predisposto per rubinetteria a parete o su piano.
 Installazione ad appoggio /
 Washbasin without overflow designed for wall or countertop tap fittings.
 Installation countertop /
 Waschtisch ohne Überlauf, geeignet für Wand- oder Standarmaturen.
 Aufgesetzte Installation

Opzione colore / Color options / Faberoption

- Bianco lucido
- Bianco opaco
- Agave
- Ardesia
- Bistro
- Cenere
- Creta
- Ghiaccio
- Tortora

Installazione / Installation / Installation

Appoggio / Countertop / Aufsatzwaschbecken

60x37
945805



Ø45
942705



Ø40
942605



Ø32
943505



Kube X 60x37 Creta
 Lavabo / Washbasin / Waschbecken



Pura 60x37 Tortora
Lavabo / Washbasin / Waschbecken

Lavabo senza foro troppopieno predisposto per rubinetteria a parete e su piano.
Installazione ad appoggio /
Washbasin without overflow designed for wall or countertop tap fittings.
Countertop installation /
Waschtisch ohne Überlauf, geeignet für Wand- und Standarmaturen.
Aufgesetzte Installation

Opzione colore / Color options / Faberoption

- | | |
|-------------------------------------|--------------------------------|
| <input type="radio"/> Bianco lucido | <input type="radio"/> Creta |
| <input type="radio"/> Bianco opaco | <input type="radio"/> Ghiaccio |
| <input type="radio"/> Agave | <input type="radio"/> Tortora |
| <input type="radio"/> Ardesia | |
| <input type="radio"/> Bistro | |
| <input type="radio"/> Cenere | |

Installazione / Installation / Installation

Appoggio / Countertop / Aufsatzwaschbecken

60x42
884205



60x37
883405



50x35
886005



Pura 60x42 Bistro
Lavabo / Washbasin / Waschbecken

Lavabo senza foro troppopieno predisposto per rubinetteria a parete e su piano.
 Lavabo con troppopieno nella versione Ø42 art. 885511. Installazione ad appoggio /
 Washbasin without overflow designed for wall or countertop tap fittings.
 Washbasin with overflow in the model Ø42 art. 885511. Countertop installation /
 Waschtisch ohne Überlauf, geeignet für Wand- und Standarmaturen.
 Waschtisch mit Überlauf in der Version Ø42 art. 885511. Aufgesetzte Installation

Opzione colore / Color options / Faberoption

- | | |
|-------------------------------------|--------------------------------|
| <input type="radio"/> Bianco lucido | <input type="radio"/> Creta |
| <input type="radio"/> Bianco opaco | <input type="radio"/> Ghiaccio |
| <input type="radio"/> Agave | <input type="radio"/> Tortora |
| <input type="radio"/> Ardesia | |
| <input type="radio"/> Bistro | |
| <input type="radio"/> Cenere | |

Installazione / Installation / Installation

Appoggio / Countertop / Aufsatzwaschbecken

Ø42
885105



Ø42
885505



Ø42 h22
885205



Ø32
885405

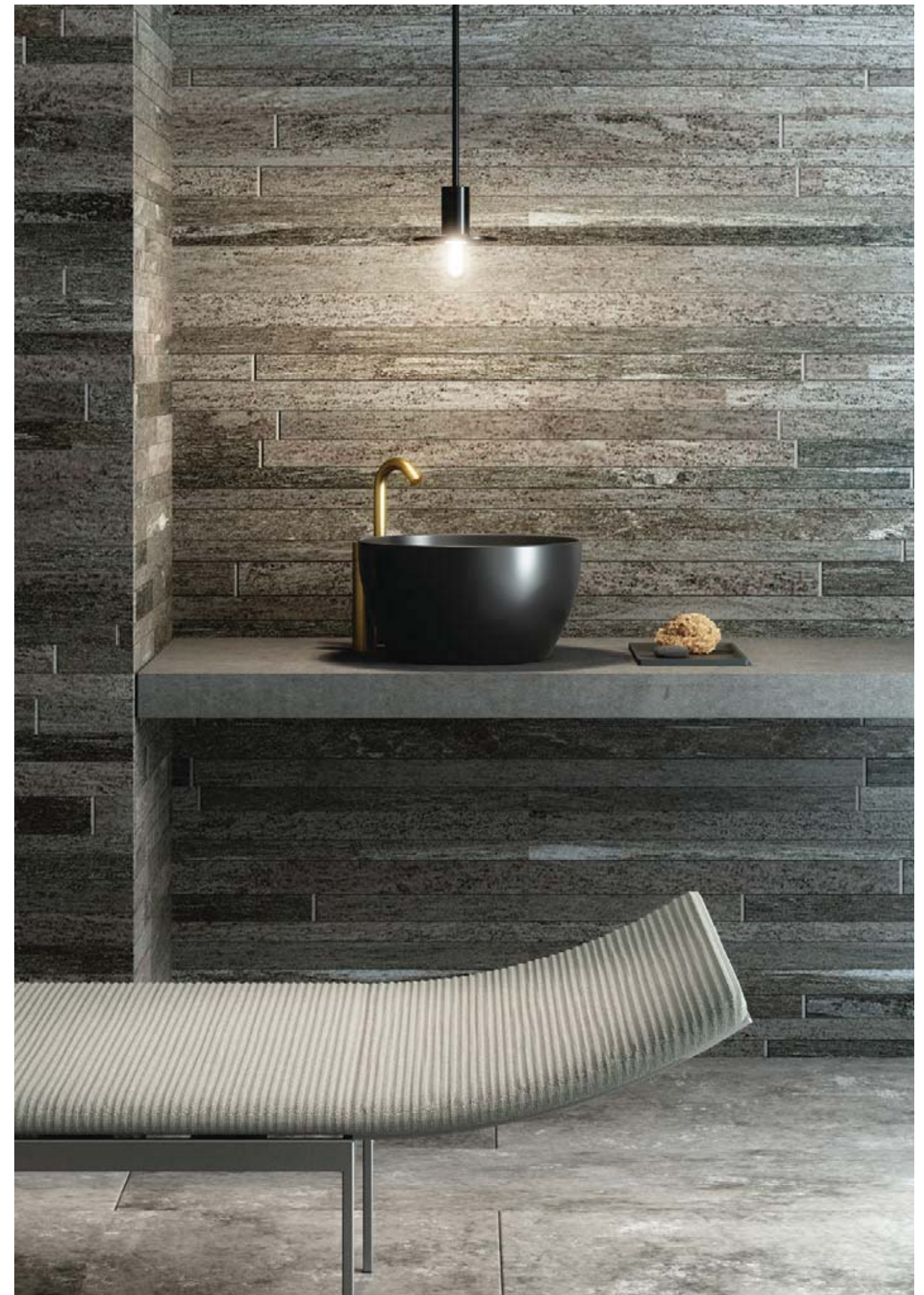

Pura Ø42 h22 Ardesia
 Lavabo / Washbasin / Waschbecken

96 Lavabo senza foro troppopieno, predisposto per rubinetteria a parete o su piano. Installazione ad appoggio o ad incasso / Washbasin without overflow designed for wall or countertop tap fittings. Countertop or built-in installation / Waschtisch ohne Überlauf, geeignet für Wand- oder Standarmaturen. Für Aufsatz- oder Einbaumontage

Opzione colore / Color options / Faberoption

- | | |
|-------------------------------------|--------------------------------|
| <input type="radio"/> Bianco lucido | <input type="radio"/> Creta |
| <input type="radio"/> Bianco opaco | <input type="radio"/> Ghiaccio |
| <input type="radio"/> Agave | <input type="radio"/> Tortora |
| <input type="radio"/> Ardesia | |
| <input type="radio"/> Bistro | |
| <input type="radio"/> Cenere | |

Installazione / Installation / Installation

- Appoggio / Countertop / Aufsatzwaschbecken
- Incasso / Built-in / Einbaumontage

60×38
883705



50×38
884705



38×38
885005



Ø40
884605



Pura Ø40 Bianco opaco
Lavabo / Washbasin / Waschbecken



Pura 55×36/F Ghiaccio
Wc e bidet / Wc and bidet / Wc und Bidet

Wc sospeso con sistema di scarico Swirflush®.
Bidet sospeso con foro troppopieno e monoforo per rubinetteria /
Wall-hung Wc with Swirflush® flushing system.
Wall-hung bidet with overflow and single taphole for tap fitting /
WC in Wandaufhängung mit Spülsystem Swirflush®.
Bidet wandhängend mit Überlauf und Hahnlochbefestigung

Opzione colore / Color options / Faberoption

- | | |
|-------------------------------------|--------------------------------|
| <input type="radio"/> Bianco lucido | <input type="radio"/> Creta |
| <input type="radio"/> Bianco opaco | <input type="radio"/> Ghiaccio |
| <input type="radio"/> Agave | <input type="radio"/> Tortora |
| <input type="radio"/> Ardesia | |
| <input type="radio"/> Bistro | |
| <input type="radio"/> Cenere | |

55×36/F
881505



55×36
8865105



quickrelease



softclose



dualglaze



Pura 55×36/F Creta
Wc e bidet / Wc and bidet / Wc und Bidet



Pura 50x36/F Ardesia
Wc

Wc sospeso con fissaggio dal basso e sistema di scarico Swirlflush®.
Bidet sospeso con foro troppopieno e monoforo per rubinetteria.
Sistema di fissaggio dal basso /
Wc with concealed fixtures and with Swirlflush® flushing system.
Wall-hung bidet with overflow and single taphole for tap fittings.
Concealed fixtures /
WC in Wandaufhängung mit verdeckter Befestigung mit Spülsystem Swirlflush®.
Bidet wandhängend mit Überlauf und Hahnlochbefestigung.
Mit verdeckter Befestigung

Opzione colore / Color options / Faberoption

- Bianco lucido
- Bianco opaco
- Agave
- Ardesia
- Bistro
- Cenere
- Creta
- Ghiaccio
- Tortora

50x36/F
881605



50x36
8864105



quickrelease



softclose



dualglaze



Pura 50x36/F Tortora
Wc e bidet / Wc and bidet / Wc und Bidet

102 Wc da terra con scarico Swirflush®. Bidet da terra con foro troppopieno e monoforo per rubinetteria / Floor standing Wc with Swirflush® flushing system. Floor standing bidet with overflow and single taphole for tap fittings / WC in Bodenmontage mit Spülsystem Swirflush®. Bidet in Bodenmontage mit Überlauf und Hahnlochbefestigung

Opzione colore / Color options / Faberoption

- Bianco lucido
- Bianco opaco
- Agave
- Ardesia
- Bistro
- Cenere
- Creta
- Ghiaccio
- Tortora

55x36/F
881005



55x36
8862105



Pura 55x36/F Agave
Wc e bidet / Wc and bidet / Wc und Bidet

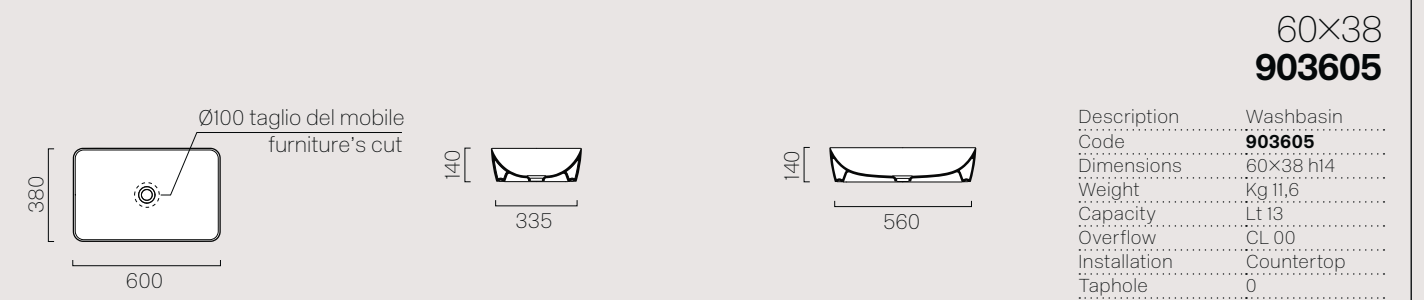
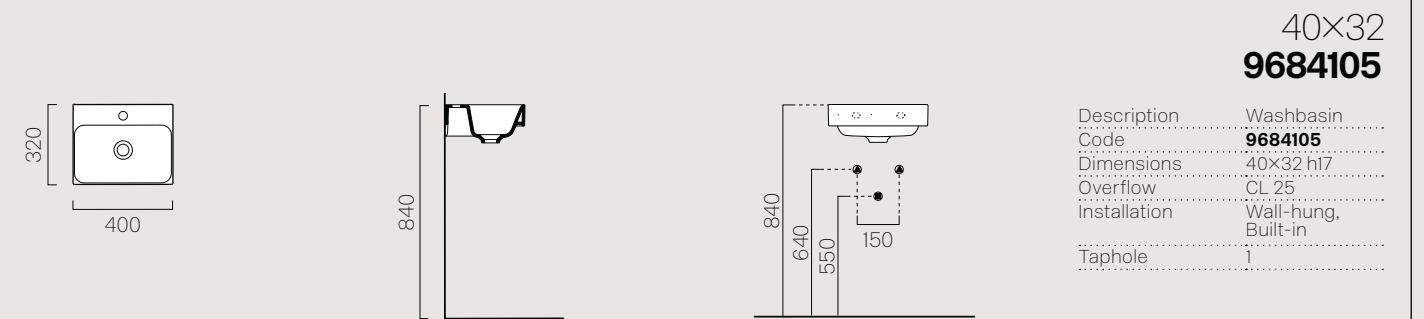

38×38 903805

Description	Washbasin
Code	903805
Dimensions	38×38 h14
Weight	Kg 8,5
Capacity	Lt 7
Overflow	CL 00
Installation	Countertop
Taphole	0

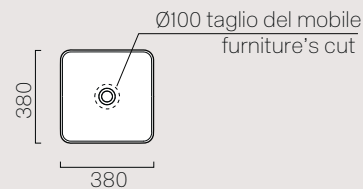

Ø40 903905

Description	Washbasin
Code	903905
Dimensions	Ø40 h14
Weight	Kg 7,7
Capacity	Lt 6
Overflow	CL 00
Installation	Countertop
Taphole	0



50×25 9486005

Description	Washbasin
Code	9486005
Dimensions	50×25 h13
Weight	Kg 9,1
Capacity	Lt 4
Overflow	CL 00
Installation	Wall-hung, Countertop
Taphole	0 (1)

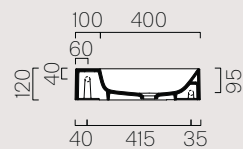
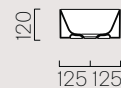
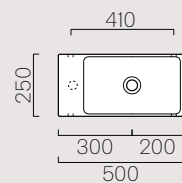

40×23 9484005

Description	Washbasin
Code	9484005
Dimensions	40×23 h11,5
Weight	Kg 7,4
Capacity	Lt 2,5
Overflow	CL 00
Installation	Wall-hung, Countertop
Taphole	0 (1)

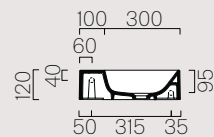
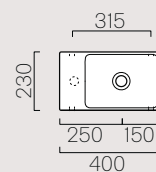

60×37 945305

Description	Washbasin
Code	945305
Dimensions	60×37 h13
Weight	Kg 14,2
Capacity	Lt 9
Overflow	CL 00
Installation	Countertop
Taphole	0

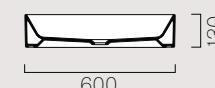
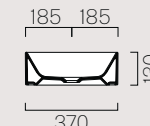
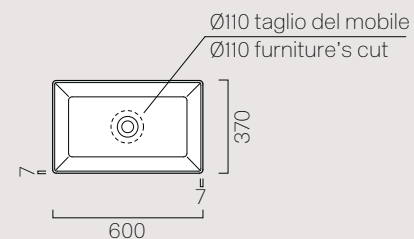

50×37 942905

Description	Washbasin
Code	942905
Dimensions	50×37 h13
Weight	Kg 11,5
Capacity	Lt 7
Overflow	CL 00
Installation	Countertop
Taphole	0

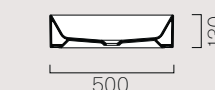
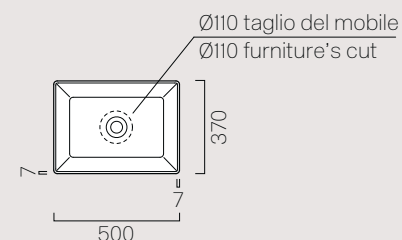

60×37 945805

Description	Washbasin
Code	945805
Dimensions	60×37 h13
Weight	Kg 11,2
Overflow	CL 00
Installation	Countertop
Taphole	0

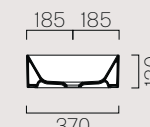
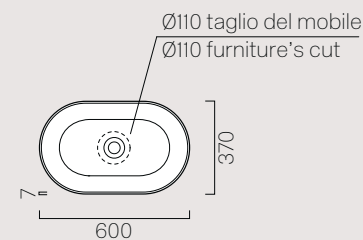

Ø45 942705

Description	Washbasin
Code	942705
Dimensions	Ø45
Overflow	CL 00
Installation	Countertop
Taphole	0

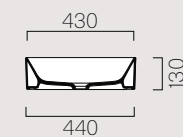
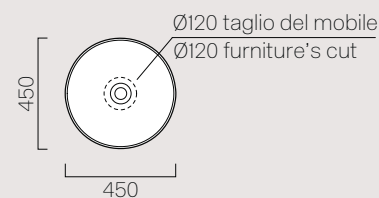

Ø40 942605

Description	Washbasin
Code	942605
Dimensions	Ø40
Overflow	CL 00
Installation	Countertop
Taphole	0

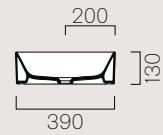
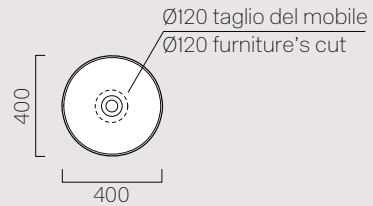

Ø32 943505

Description	Washbasin
Code	943505
Dimensions	Ø32
Weight	Kg 5,5
Capacity	Lt 3
Overflow	CL 00
Installation	Countertop
Taphole	0

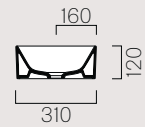
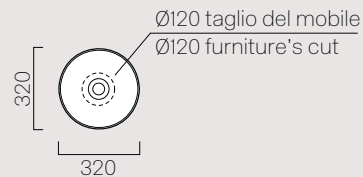

60×42 884205

Description	Washbasin
Code	884205
Dimensions	60×42
Weight	Kg 9,9
Capacity	Lt 10
Overflow	CL 00
Installation	Countertop
Taphole	0

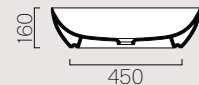
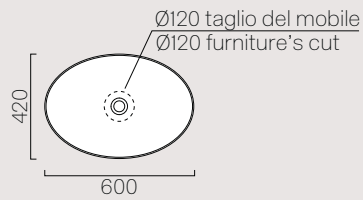

60×37 883405

Description	Washbasin
Code	883405
Dimensions	60×37
Weight	Kg 11
Capacity	Lt 9
Overflow	CL 00
Installation	Countertop
Taphole	0

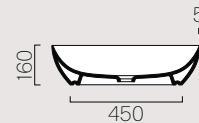
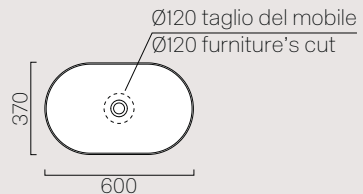

50×35 886005

Description	Washbasin
Code	886005
Dimensions	50×35
Weight	Kg 7,9
Capacity	Lt 5
Overflow	CL 00
Installation	Countertop
Taphole	0

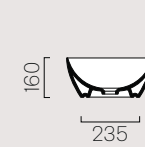
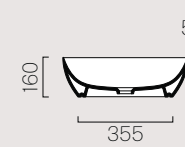
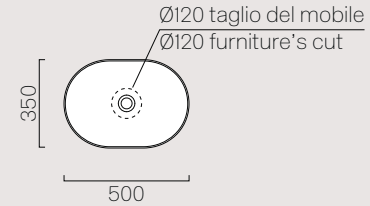

Ø42 885105

Description	Washbasin
Code	885105
Dimensions	Ø42
Weight	Kg 7,8
Capacity	Lt 7
Overflow	CL 00
Installation	Countertop
Taphole	0

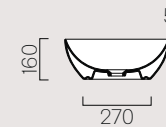
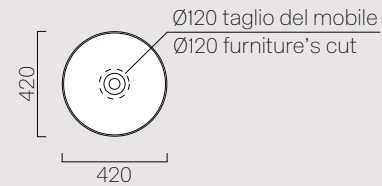

Ø42 885505

Description	Washbasin
Code	885505
Dimensions	Ø42
Weight	Kg 7,8
Capacity	Lt 7
Overflow	CL 00
Installation	Countertop
Taphole	0

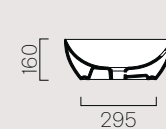
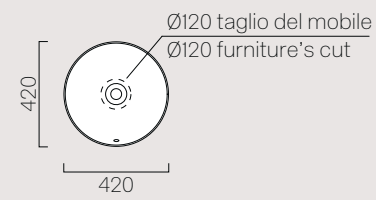

Ø42 h22 885205

Description	Washbasin
Code	885205
Dimensions	Ø42
Weight	Kg 10
Capacity	Lt 11
Overflow	CL 00
Installation	Countertop
Taphole	0

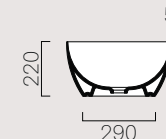
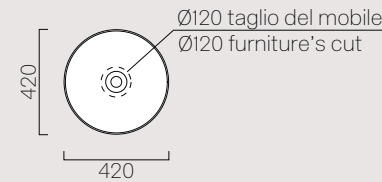

Ø32 885405

Description	Washbasin
Code	885405
Dimensions	Ø32
Overflow	CL 00
Installation	Countertop
Taphole	0



Ø40 884605

Description	Washbasin
Code	884605
Dimensions	Ø40 h14
Weight	Kg 7,5
Capacity	Lt 5
Overflow	CL 00
Installation	Built-in, Countertop
Taphole	0



60×38 883705

Description	Washbasin
Code	883705
Dimensions	60×38 h14
Weight	Kg 12,8
Capacity	Lt 9
Overflow	CL 00
Installation	Built-in, Countertop
Taphole	0

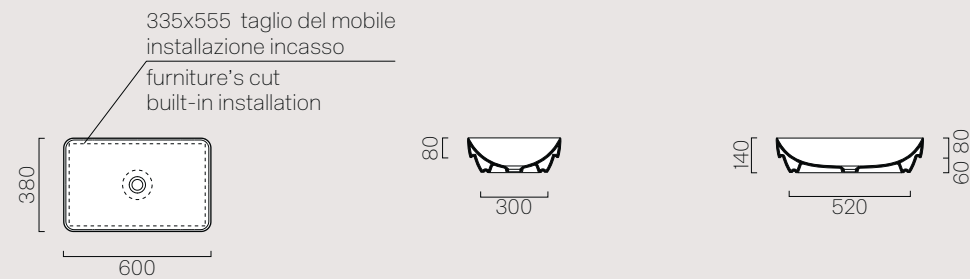

Wc e Bidet/Wc and Bidet/Wc und bidet

50×38 884705

Description	Washbasin
Code	884705
Dimensions	50×38 h14
Weight	Kg 10,1
Capacity	Lt 7
Overflow	CL 00
Installation	Built-in, Countertop
Taphole	0

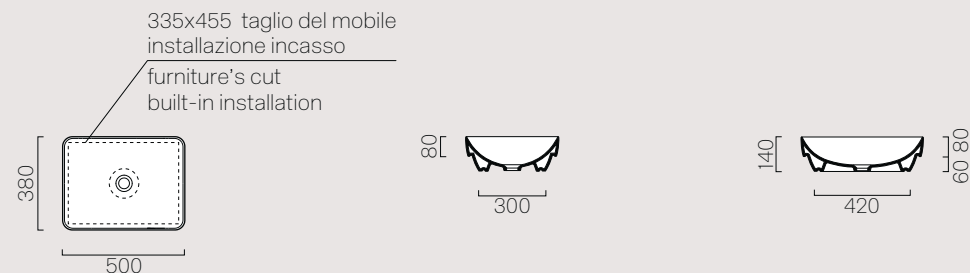

55×36/F 881505

Description	Wc
Code	881505
Dimensions	55×36
Weight	Kg 18,5
Flush system	Swiriflush®
Installation	Wall-hung

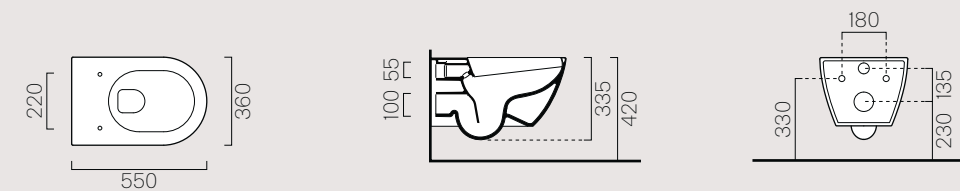

Non è consigliato l'impiego di cassette di scarico esterne o impianti dotati di rubinetto flussometro /
We do not recommend the use of external flushing cisterns or systems endowed with flushometer valves /
Empfohlen wird die Verwendung eines externen Spülkastens oder einer Selbstschlussarmatur

38×38 885005

Description	Washbasin
Code	885005
Dimensions	38×38 h14
Weight	Kg 8,7
Capacity	Lt 5
Overflow	CL 00
Installation	Built-in, Countertop
Taphole	0



55×36 8865105

Description	Bidet
Code	8865105
Dimensions	55×36
Weight	Kg 17
Overflow	CL 25
Installation	Wall-hung
Taphole	1

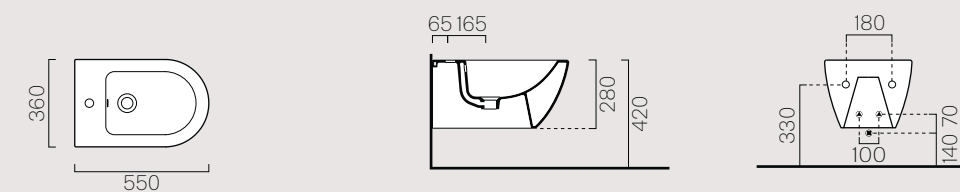

50x36/F
881605

Description	Wc
Code	881605
Dimensions	50x36
Weight	Kg 22,8
Flush system	Swirlflush®
Installation	Wall-hung

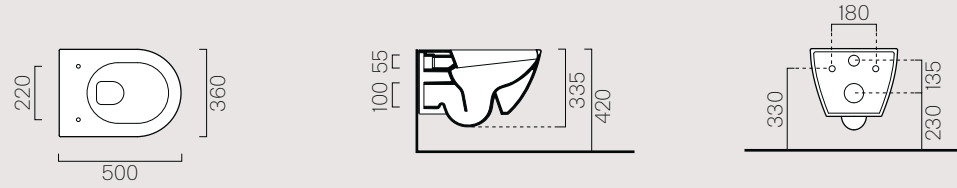

Non è consigliato l'impiego di cassette di scarico esterne o impianti dotati di rubinetto flussometro /
We do not recommend the use of external flushing cisterns or systems endowed with flushometer valves /
Empfohlen wird die Verwendung eines externen Spülkastens oder einer Selbstschlussarmatur

55x36
8862105

Description	Bidet
Code	8862105
Dimensions	55x36
Weight	Kg 23,1
Overflow	CL 25
Installation	Floor standing
Taphole	1

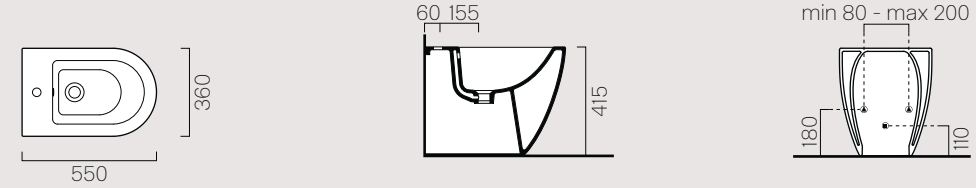

50x36
8864105

Description	Bidet
Code	8864105
Dimensions	50x36
Weight	Kg 16,3
Overflow	CL 25
Installation	Wall-hung
Taphole	1

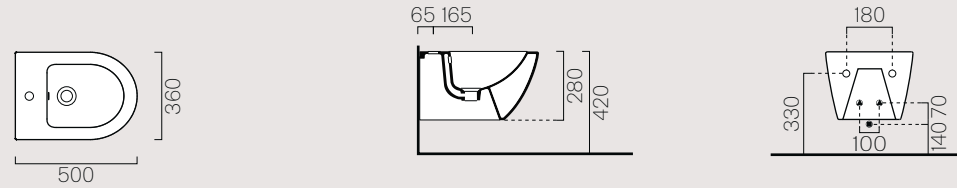

55x36/F
881005

Description	Wc
Code	881005
Dimensions	55x36
Weight	Kg 23,5
Flush system	Swirlflush®
Installation	Floor standing

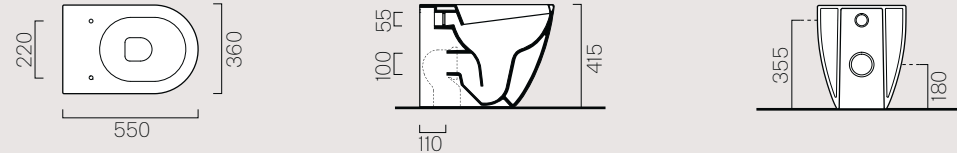

Curva tecnica /
Technical curve



MCURVA

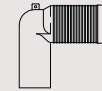

MCURVA90

Codice /
Codes

Interasse /
Distance

*110

*70

Non è consigliato l'impiego di cassette di scarico esterne o impianti dotati di rubinetto flussometro /
We do not recommend the use of external flushing cisterns or systems endowed with flushometer valves /
Empfohlen wird die Verwendung eines externen Spülkastens oder einer Selbstschlussarmatur



IT Rigore, leggerezza e versatilità, caratteristiche portanti della collezione Nubes. Una collezione raffinata che comprende prodotti d'avanguardia sia da un punto di vista stilistico che tecnologico, pensata per un pubblico esigente che si identifica in un'estetica contemporanea. I tratti distintivi dei lavabi Nubes sono la forma squadrata e un'innata versatilità conferita dal profilo a doppia fascia che consente l'installazione a sospensione, su mobile o mensola. Il bordo perimetrale, con i suoi soli otto centimetri a vista, attribuisce leggerezza ed equilibrio tra forma e spazio.

EN Rigour, lightness and versatility: these are the main features of the Nubes collection. A refined collection of cutting-edge products from both a stylistic and technological point of view, for demanding customers seeking a contemporary aesthetic. The distinguishing features of Nubes washbasins are their squareness and inherent versatility, provided by a dual fascia profile, allowing a wall-mounted, built-in or shelf-mounted installation. The edge of the basin, just eight centimetres of which are visible, provides lightness and balance between form and space.

DE Die stilistische Strenge, ihre Leichtigkeit und Vielseitigkeit sind grundlegende Merkmale der Kollektion Nubes. Eine raffinierte Kollektion mit Produkten, die sowohl in stilistischer als auch technologischer Hinsicht wegweisend sind und für eine anspruchsvolle Kundschaft entwickelt worden sind, die sich mit einer zeitgenössischen Ästhetik identifiziert. Die unterscheidenden Merkmale der Nubes Waschbecken sind ihre eckige Form und die angeborene Vielseitigkeit, die ihnen von ihrem Profil mit doppeltem Randstreifen verliehen wird, das die Montage sowohl hängend als auch auf Unterschrank oder Konsole aufgesetzt gestattet. Der nur auf acht Zentimeter Breite sichtbare Umrandungsstreifen verleiht Leichtigkeit und wahrt das Gleichgewicht zwischen Form und Raum.

60x38
Lavabo / Washbasin / Waschbecken
52x35/F
Wc e bidet / Wc and bidet / Wc und Bidet

Nubes

120×50
9625111
p.124



120×50
9624111
p.126



100×50
9651111
p.126



100×50
9623111
p.126



80×50
9622111
p.128



60×50*
9631111
p.128



70×40
9687111
p.130



60×40
9683111
p.130



50×40*
9682111
p.130



40×32
9684111
p.132
p.82 →



36×28
9638111
p.132



50×25**
9637011
p.134



40×23**
9636011
p.134



*Disponibile anche in Bianco opaco /
Also available Bianco opaco /
Erhältlich in Bianco opaco

60×38
903611
p.136
p.84 →



50×38
903711
p.136
p.84 →



38×38
903811
p.136
p.84 →



Ø40
903911
p.138
p.84 →



**Disponibile anche in Bianco opaco e Ardesia /
Also available Bianco opaco and Ardesia /
Erhältlich in Bianco opaco and Ardesia

55×35/F*
961511
9665111
p.140



50×35/F*
961611
9664111
p.140



52×35/F*
961011
9662111
p.142



185×90
VASAND90
p.144



180×80*
VASAND80
p.144





185x90
 Vasca / Bathtub / Badewanne

120x50
 Lavabo / Washbasin / Waschbecken

55x35/F
 Wc e bidet / Wc and bidet / Wc und Bidet



52x35/F
 Wc e bidet / Wc and bidet / Wc und Bidet



80x50
 Lavabo / Washbasin / Waschbecken



100x50
Lavabo / Washbasin / Waschbecken

55x35/F
Wc e bidet / Wc and bidet / Wc und Bidet

124 Lavabo con foro troppopieno e monoforo per rubinetteria, predisposto per tre fori. Installazione a sospensione o ad incasso / Washbasin with overflow and one taphole for tap fittings, designed for three tapholes. Wall-hung or built-in installation / Waschtisch mit Überlauf und Hahnlochbefestigung für drei Löcher. Für Wand- oder Einbaumontage

Opzione colore / Color options / Faberoption

Bianco lucido

Installazione / Installation / Installation

Sospensione / Wall-hung / Wanshängend

Incasso / Built-in / Einbaumontage

120x50
962511



extraglazeantibacterial®



120x50
Lavabo / Washbasin / Waschbecken



120×50
Lavabo / Washbasin / Waschbecken

Lavabo con foro troppopieno e monoforo per rubinetteria, predisposto per cinque fori o tre fori (nella versione con piani d'appoggio 9651111).
 Installazione a sospensione o ad incasso /
 Washbasin with overflow and one taphole for tap fittings, designed for five tapholes or three tapholes (in the version with countertop 9651111).
 Wall-hung or built-in installation /
 Waschtisch mit Überlauf und Einlocharmatur, geeignet für fünf oder drei Löcher (in der Ausführung mit Stellflächen 9651111). Für Wand- oder Einbaumontage

Opzione colore / Color options / Faberoption

Bianco lucido

Installazione / Installation / Installation

Sospensione / Wall-hung / Wanshängend

Incasso / Built-in / Einbaumontage

120×50
962411



100×50
962311



100×50
965111



extraglazeantibacterial®



100×50
Lavabo / Washbasin / Waschbecken

128 Lavabo con foro troppopieno e monoforo per rubinetteria, predisposto per tre fori. Disponibile in bianco opaco solo per il modello 60x50 9631111. Installazione a sospensione o ad incasso / Washbasin with overflow and one taphole for tap fittings, designed for three tapholes. Available in matt white only for the model 60x50 9631111. Wall-hung or built-in installation / Waschtisch mit Überlauf und Hahnlochbefestigung für drei Löcher. Erhältlich in Bianco matt nur für Modell 60x50 9631111. Für Wand- oder Einbaumontage

Opzione colore/Color options/Faberoption

- Bianco lucido
- Bianco opaco (9631111)

Installazione/Installation/Installation

- Sospensione/Wall-hung/Wanshängend
- Incasso/Built-in/Einbaumontage

80x50
9622111



60x50
9631111



Solo per /
Only for /
Nur für
Bianco lucido



extraglazeantibacterial®



80x50
Lavabo / Washbasin / Waschbecken

Lavabo con foro troppopieno e monoforo per rubinetteria, predisposto per tre fori. Disponibile in bianco opaco solo per il modello 50x40 9682111. Installazione a sospensione o ad incasso / Washbasin with overflow and one taphole for tap fittings, designed for three tapholes. Available in matt white only for the model 50x40 9682111. Wall-hung or built-in installation / Waschtisch mit Überlauf und Hahnlochbefestigung für drei Löcher. Erhältlich in Bianco matt nur für Modell 50x40 9682111. Für Wand- oder Einbaumontage

Opzione colore / Color options / Faberoption

- Bianco lucido
- Bianco opaco (9682111)

Installazione / Installation / Installation

- Sospensione / Wall-hung / Wanshängend
- Incasso / Built-in / Einbaumontage

70x40
9687111



60x40
9683111



50x40
9682111



Solo per /
Only for /
Nur für
Bianco lucido



extraglazeantibacterial®



70x40
Lavabo / Washbasin / Waschbecken

Lavabo con foro troppopieno e monoforo per rubinetteria, disponibile nelle finiture Color Elements solo per il modello 40x32 9684111.
 Installazione a sospensione o ad incasso /
 Washbasin with overflow and one taphole for tap fittings. Available in Color Elements finishings only for the model 40x32 9684111.
 Wall-hung or built-in installation /
 Waschtisch mit Überlauf und Hahnlochbefestigung. Erhältlich in Color Elements nur für Modell 40x32 9684111.
 Für Wand- oder Einbaumontage

Opzione colore/Color options/Faberoption

- | | |
|-------------------------------------|--------------------------------|
| <input type="radio"/> Bianco lucido | <input type="radio"/> Creta |
| <input type="radio"/> Bianco opaco | <input type="radio"/> Ghiaccio |
| <input type="radio"/> Agave | <input type="radio"/> Tortora |
| <input type="radio"/> Ardesia | |
| <input type="radio"/> Bistro | |
| <input type="radio"/> Cenere | |

Installazione/Installation/Installation

- Sospensione/Wall-hung/Wanshängend
- Incasso/Built-in/Einbaumontage

40x32
9684111



36x28
9638111



Solo per /
 Only for /
 Nur für
 Bianco lucido



extraglazeantibacterial®



40x32
 Lavabo / Washbasin / Waschbecken

Lavabo senza foro troppopieno predisposto per rubinetteria monoforo laterale. Installazione sospesa (con fori laterali posteriori per l'aggancio a parete) o ad incasso (con tutti i lati a vista smaltati). Disponibile nelle finiture Color Elements Bianco opaco e Ardesia / Washbasin without overflow, designed for single lateral taphole. Installation wall-hung (with rear lateral holes for wall fitting) or built in (with all visible surfaces glazed). Available in Color Elements finishings Matt White and Ardesia / Waschtisch ohne Überlauf, geeignet für seitliche Hahnlochbefestigung. Wandinstallation (mit seitlichen hinten angebrachten Öffnungen für Wandaufhängung) oder Einbaumontage (alle Sichtseiten glasiert) Erhältlich in den ColorElements-Ausführungen Bianco matt und Ardesia

Opzione colore / Color options / Faberoption

- Bianco lucido
 Bianco opaco
 Ardesia

Installazione / Installation / Installation

- Sospensione / Wall-hung / Wanshängend
 Incasso / Built-in / Einbaumontage

50x25
9637011



40x23
9636011



Solo per /
 Only for /
 Nur für
 Bianco lucido



extraglaze antibacterial®



40x23
 Lavabo / Washbasin / Waschbecken

136 Lavabo senza foro troppopieno predisposto per rubinetteria a parete o su piano.
 Installazione ad appoggio. Disponibile nelle finiture Color Elements /
 Washbasin without overflow designed for wall or countertop tap fittings.
 Countertop installation. Available in Color Elements finishings /
 Waschtisch ohne Überlauf, geeignet für Wand- oder Standarmaturen. Aufge-
 setzte Installation. Erhältlich in den Ausführungen Color Elements

Opzione colore / Color options / Faberoption

- Bianco lucido
- Bianco opaco
- Agave
- Ardesia
- Bistro
- Cenere
- Creta
- Ghiaccio
- Tortora

Installazione / Installation / Installation

 Appoggio / Countertop / Aufsatzwaschbecken

60x38
903611



50x38
903711



38x38
903811



Solo per /
Only for /
Nur für
Bianco lucido



60x38
Lavabo / Washbasin / Waschbecken

138 Lavabo senza foro troppopieno predisposto per rubinetteria a parete o su piano.
Installazione ad appoggio. Disponibile nelle finiture Color Elements /
Washbasin without overflow designed for wall or countertop tap fittings.
Countertop installation. Available in Color Elements finishings /
Waschtisch ohne Überlauf, geeignet für Wand- oder Standarmaturen. Aufge-
setzte Installation. Erhältlich in den Ausführungen Color Elements

Opzione colore / Color options / Faberoption

- | | |
|-------------------------------------|--------------------------------|
| <input type="radio"/> Bianco lucido | <input type="radio"/> Creta |
| <input type="radio"/> Bianco opaco | <input type="radio"/> Ghiaccio |
| <input type="radio"/> Agave | <input type="radio"/> Tortora |
| <input type="radio"/> Ardesia | |
| <input type="radio"/> Bistro | |
| <input type="radio"/> Cenere | |

Installazione / Installation / Installation

Appoggio / Countertop / Aufsatzwaschbecken

Ø40
903911



Solo per /
Only for /
Nur für
Bianco lucido



extraglazeantibacterial®



Ø40
Lavabo / Washbasin / Waschbecken

140 Wc sospeso con sistema di scarico Swirlflush®. Bidet sospeso con foro troppopieno e monoforo per rubinetteria. Disponibile nella finitura Color Element Bianco opaco / Wall-hung wc with Swirlflush® flushing system. Wall-hung bidet with overflow and one taphole for tap fittings. Available in Color Elements finishings Matt White / WC wandhängend mit Spülsystem Swirlflush® Bidet wandhängend mit Überlauf und Hahnlochbefestigung. Lieferbar in der Ausführung Color Element Bianco matt

Opzione colore/Color options/Faberoption

- Bianco lucido
- Bianco opaco

55x35/F
961511



55x35
9665111



50x35/F
961611



50x35
9664111



Solo per /
Only for /
Nur für
Bianco lucido



Solo per /
Only for /
Nur für
Color elements



55x35/F
Wc e bidet / Wc and bidet / Wc und Bidet

Wc in appoggio con sistema di scarico Swirlflush®, predisposto per scarico a parete o a pavimento tramite curva tecnica. Bidet in appoggio con foro troppopieno e monoforo per rubinetteria. Disponibili nella finitura Color Element Bianco opaco / Floor standing wc with Swirlflush® flushing system, designed for wall or floor outlet using S-curve plumbing. Floor standing bidet with overflow and one taphole for tap fittings. Available in Color Elements finishings Matt White / WC zur aufgesetzten Installation mit Spülsystem Swirlflush®, geeignet für Wand- oder Bodeninstallation mithilfe eines Anschlussbogens. Bidet zur aufgesetzten Installation mit Überlauf und Hahnlochbefestigung. Lieferbar in der Ausführung Color Element Bianco matt

Opzione colore/Color options/Faberoption

- Bianco lucido
- Bianco opaco

52x35/F
961011



52x35
9662111



Solo per /
Only for /
Nur für
Bianco lucido



extraglazeantibacterial®



swirlflush®



quickrelease



softclose



dualglaze

Solo per /
Only for /
Nur für
Color elements



52x35/F
Wc e bidet / Wc and bidet / Wc und Bidet

144 Vasca in acrilico completa di sifone e piletta nella versione in appoggio o ad incasso, quest'ultima disponibile nella finitura Color Element Bianco opaco / Acrylic bathtub including syphon and drain countertop version or built-in, this last available in Color Elements finishings Matt White / Badewanne in Acryl komplett mit Siphon und Auslauf in aufgesetzter oder Einbauversion, letztere lieferbar in der Ausführung Color Element Bianco matt

Opzione colore / Color options / Faberoption

- Bianco lucido
- Bianco opaco

Installazione / Installation / Installation

- Appoggio / Countertop / Aufsatzwaschbecken
- Incasso / Built-in / Einbaumontage

185×90
VASAND90



180×80
VASAND80



185×90
Vasca / Bathtub / Badewanne

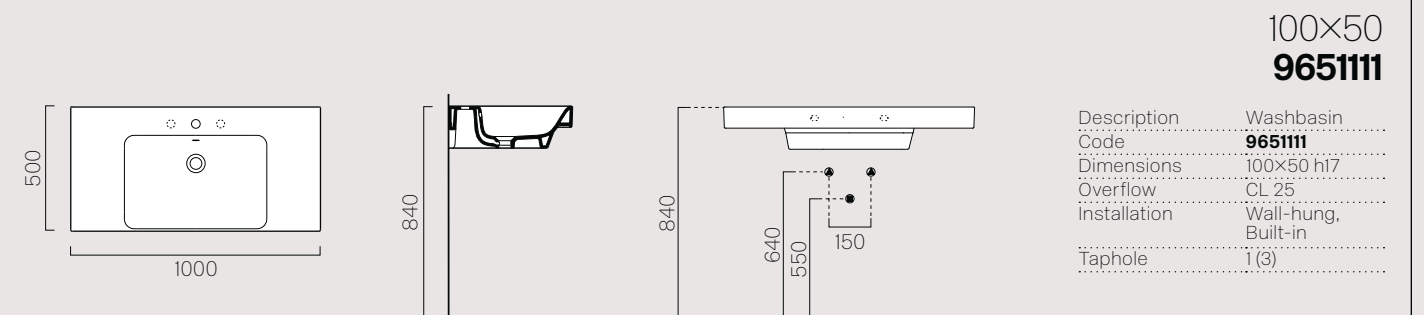
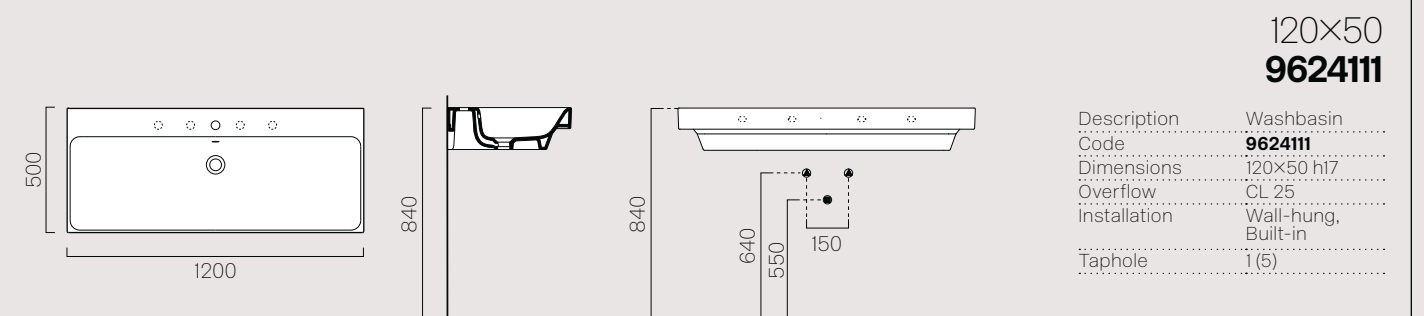
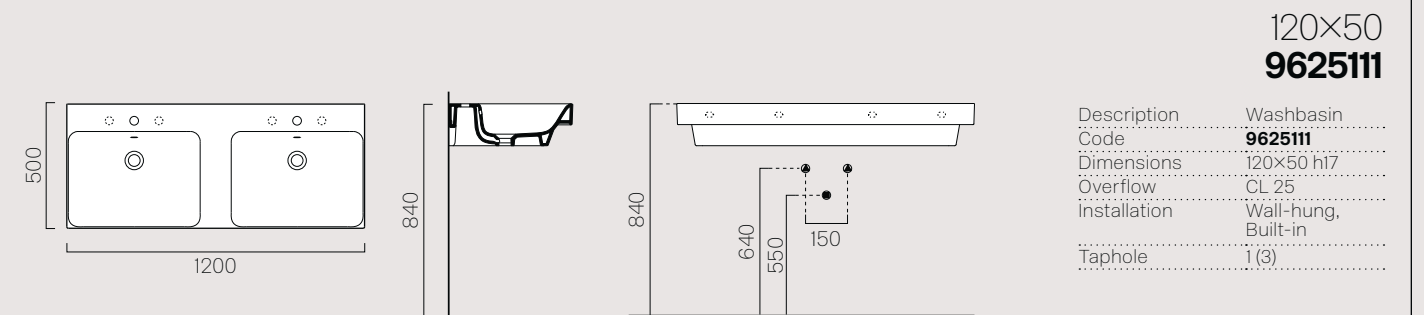

100×50
9623111

Description	Washbasin
Code	9623111
Dimensions	100×50 h17
Overflow	CL 25
Installation	Wall-hung, Built-in
Taphole	1(3)

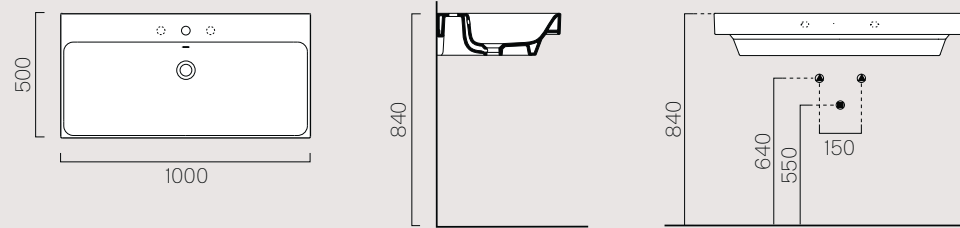

60×40
9683111

Description	Washbasin
Code	9683111
Dimensions	60×40 h17
Overflow	CL 25
Installation	Wall-hung, Built-in
Taphole	1(3)

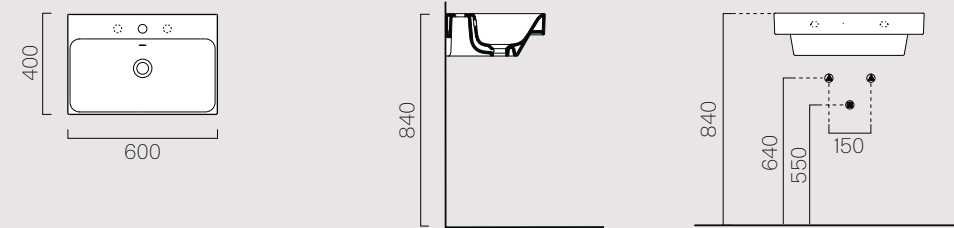

80×50
9622111

Description	Washbasin
Code	9622111
Dimensions	80×50 h17
Weight	Kg 25
Capacity	Lt 12
Overflow	CL 25
Installation	Wall-hung, Built-in
Taphole	1(3)

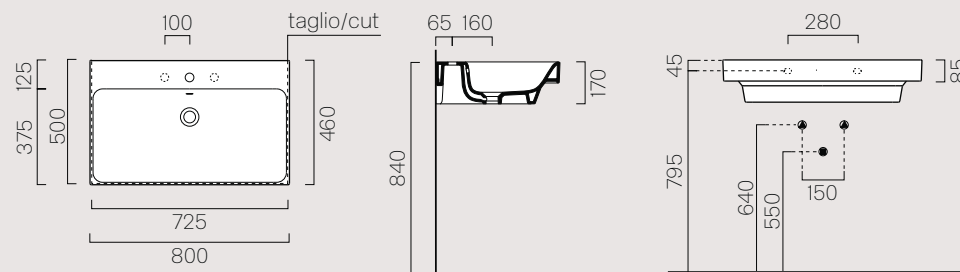

50×40
9682111

Description	Washbasin
Code	9682111
Dimensions	50×40 h17
Overflow	CL 25
Installation	Wall-hung, Built-in
Taphole	1(3)

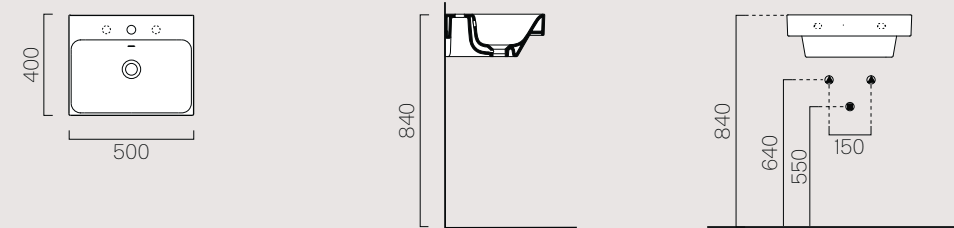

60×50
9631111

Description	Washbasin
Code	9631111
Dimensions	60×50 h17
Weight	Kg 20
Capacity	Lt 8
Overflow	CL 25
Installation	Wall-hung, Built-in
Taphole	1(3)

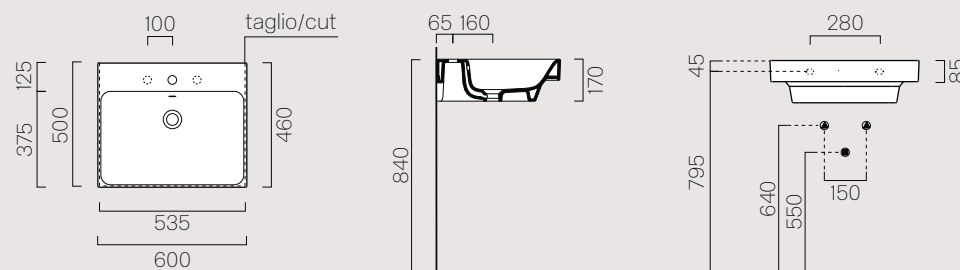

40×32
9684111

Description	Washbasin
Code	9684111
Dimensions	40×32 h17
Overflow	CL 25
Installation	Wall-hung, Built-in
Taphole	1

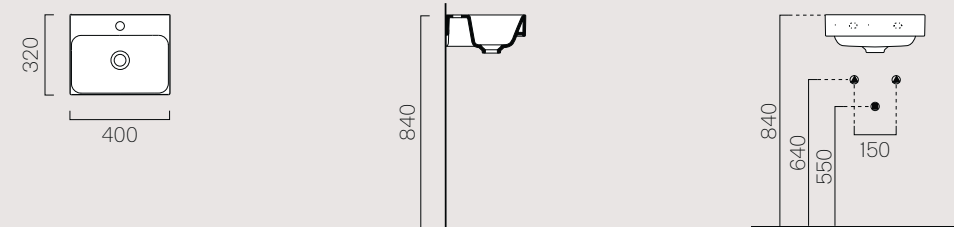

70×40
9687111

Description	Washbasin
Code	9687111
Dimensions	70×40 h17
Overflow	CL 25
Installation	Wall-hung, Built-in
Taphole	1(3)

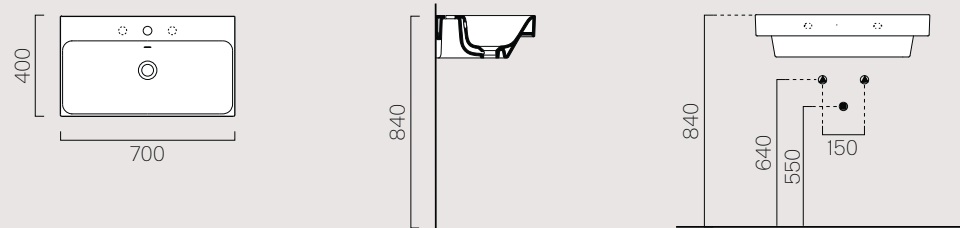

36×28
9638111

Description	Washbasin
Code	9638111
Dimensions	36×28 h17
Overflow	CL 00
Installation	Wall-hung, Built-in
Taphole	1

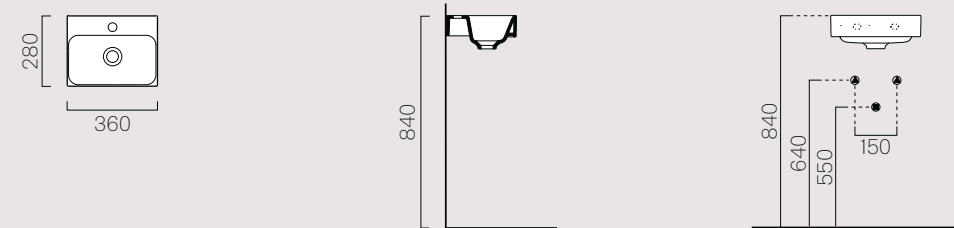

50×25 9637011

Description	Washbasin
Code	9637011
Dimensions	50×25 h13
Overflow	CL 00
Installation	Wall-hung, Countertop
Taphole	0 (1)

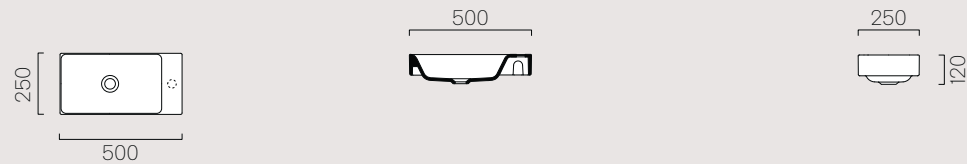

40×23 9636011

Description	Washbasin
Code	9636011
Dimensions	40×23 h11,5
Overflow	CL 00
Installation	Wall-hung, Countertop
Taphole	0 (1)

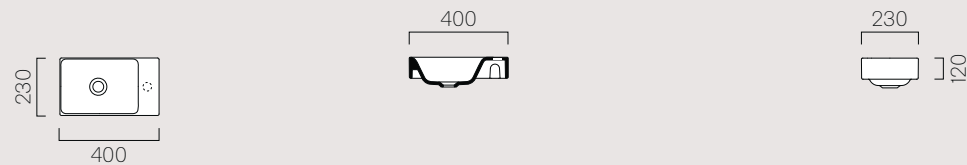

60×38 903611

Description	Washbasin
Code	903611
Dimensions	60×38 h14
Weight	Kg 11,6
Capacity	Lt 13
Overflow	CL 00
Installation	Countertop
Taphole	0

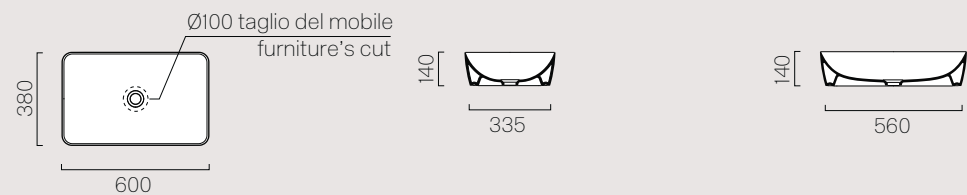

50×38 903711

Description	Washbasin
Code	903711
Dimensions	50×38 h14
Weight	Kg 10,6
Capacity	Lt 9
Overflow	CL 00
Installation	Countertop
Taphole	0

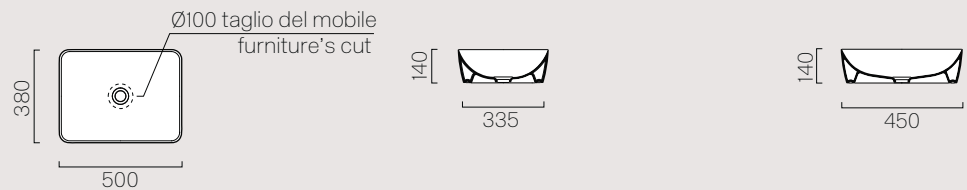

38×38 903811

Description	Washbasin
Code	903811
Dimensions	38×38 h14
Weight	Kg 8,5
Capacity	Lt 7
Overflow	CL 00
Installation	Countertop
Taphole	0



Ø40 903911

Description	Washbasin
Code	903911
Dimensions	Ø40 h14
Weight	Kg 7,7
Capacity	Lt 6
Overflow	CL 00
Installation	Countertop
Taphole	0



Wc e Bidet/Wc and Bidet/Wc und bidet

55×35/F 961511

Description	Wc
Code	961511
Dimensions	55×35
Flush system	Swiriflush®
Installation	Wall-hung

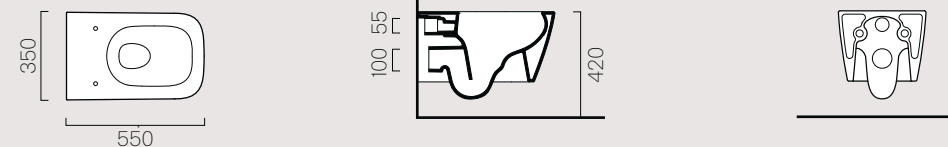

Non è consigliato l'impiego di cassette di scarico esterne o impianti dotati di rubinetto flussometro /
We do not recommend the use of external flushing cisterns or systems endowed with flushometer valves /
Empfohlen wird die Verwendung eines externen Spülkastens oder einer Selbstschlussarmatur

55x35
966511

Description	Bidet
Code	966511
Dimensions	55x35
Overflow	CL 25
Installation	Wall-hung
Taphole	1

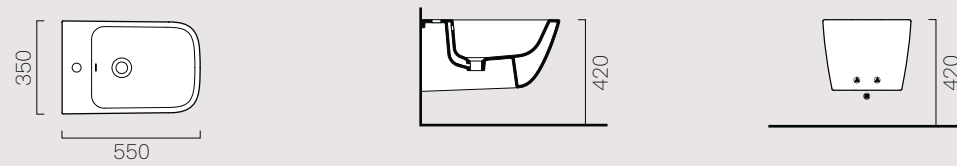

52x35
966211

Description	Bidet
Code	966211
Dimensions	52x35
Overflow	CL 25
Installation	Floor standing
Taphole	1

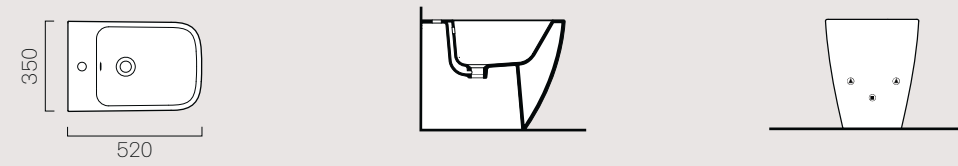

50x35/F
961611

Description	Wc
Code	961611
Dimensions	50x35
Flush system	Swirlflush®
Installation	Wall-hung

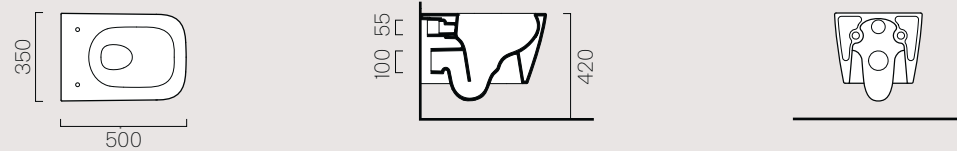

Vasca/Bathtub/Badewanne

Non è consigliato l'impiego di cassette di scarico esterne o impianti dotati di rubinetto flussometro /
We do not recommend the use of external flushing cisterns or systems endowed with flushometer valves /
Empfohlen wird die Verwendung eines externen Spülkastens oder einer Selbstschlussarmatur

50x35
9664111

Description	Bidet
Code	9664111
Dimensions	50x35
Overflow	CL 25
Installation	Wall-hung
Taphole	1

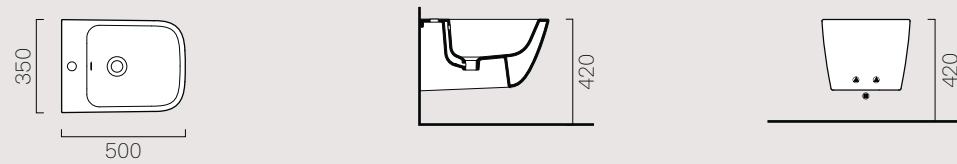

185x90
VASAND90

Description	Bathtub
Code	VASAND90
Dimensions	185x90 h62
Weight	Kg 58
Installation	Freestanding
Material	Acrylic

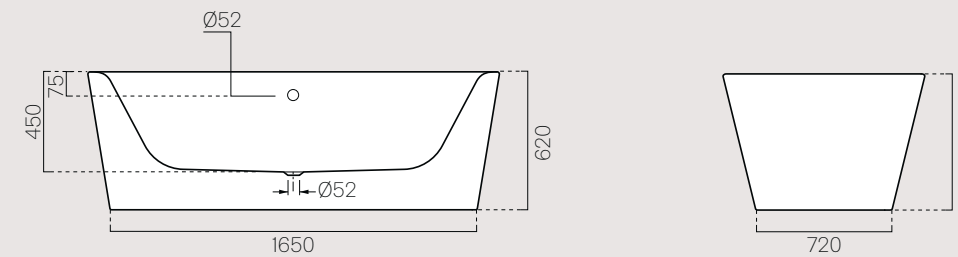

52x35/F
961011

Description	Wc
Code	961011
Dimensions	52x35
Flush system	Swirlflush®
Installation	Floor standing

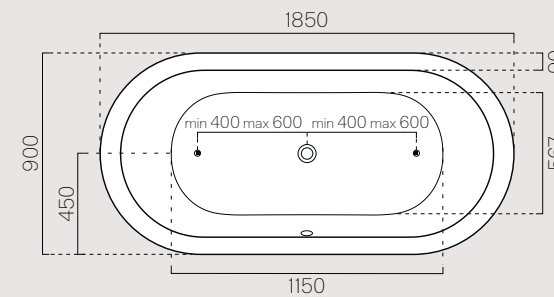
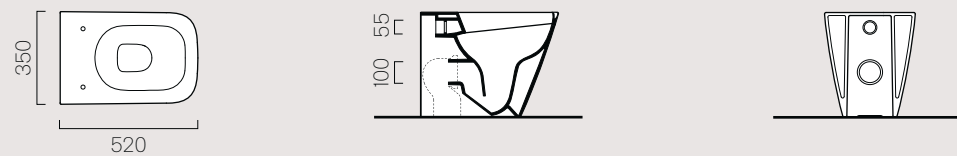

Non è consigliato l'impiego di cassette di scarico esterne o impianti dotati di rubinetto flussometro /
We do not recommend the use of external flushing cisterns or systems endowed with flushometer valves /
Empfohlen wird die Verwendung eines externen Spülkastens oder einer Selbstschlussarmatur

180x80 VASAND80

Description	Bathtub
Code	VASAND80
Dimensions	180x80 h45
Weight	Kg 36
Installation	Built-in
Material	Acrylic

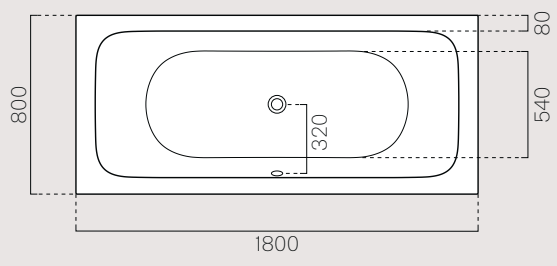
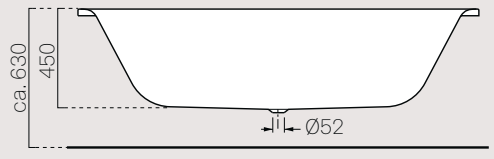



IT **Kube X affina le forme geometriche a bordo sottile secondo la tendenza contemporanea. I sanitari presentano linee epurate combinati con l'innovazione tecnologica dei plus GSI: lo smalto Extraglaze® Antibacterial, il sistema di scarico Save Water, copriwater con sistema di estrazione rapida Quick Release e sistema di chiusura rallentata, sistema di scarico Swirlflush®. Selezionati prodotti sono disponibili nelle finiture Color Elements.**

EN **Kube X pares down geometric forms to slender edges in keeping with trends in contemporary design. Sanitary ware come in essential lines and are equipped with the technical innovation of GSI extras: the Extraglaze® Antibacterial glazing, the Save Water flushing system, toilet seats with the Quick Release mechanism and slow Soft-Close system, the Swirlflush® flushing system. Select products are available in Color Elements finishings.**

DE **Kube X präsentiert sich in geometrischen Formen mit dünner Umrandung im zeitgenössischen Geschmack. Alle Keramikteile weisen reine, schlanke Linien auf und sind mit den technischen Innovationen von GSI ausgestattet: Extraglaze® Antibacterial-Glasur, Save Water-Spülsystem, Toilettensitze mit Take-off System, dem Soft-Close-System und dem Swirlflush®-System. Ausgewählte Produkte sind in den Color Elements-Ausführungen erhältlich.**

120x47

Lavabo / Washbasin / Waschbecken

55x36/F

Wc e bidet / Wc and bidet / Wc und Bidet

Kube X

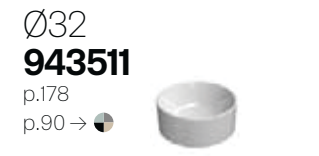
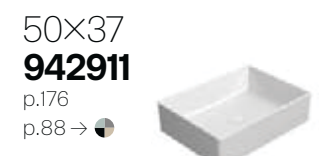
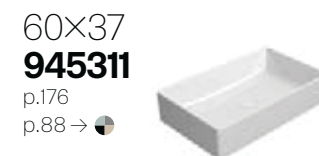

*Disponibile anche in Bianco opaco e Ardesia/
Also available Bianco opaco and Ardesia/
Erhältlich in Bianco opaco and Ardesia



120x47
 Lavabo / Washbasin / Waschbecken

55x36/F
 Wc e bidet / Wc and bidet / Wc und Bidet

Compstone
 Piatto doccia / Shower tray / Duschwanne



50x25
Lavabo / Washbasin / Waschbecken

55x36/F
Wc



120x47
Lavabo / Washbasin / Waschbecken

55x36/F
Wc e bidet / Wc and bidet / Wc und Bidet

164 Lavabo con foro troppopieno e monoforo per rubinetteria, predisposto per tre o cinque fori (solo per modello 120x47 942411). Installazione a sospensione o ad appoggio / Washbasin with overflow and single taphole for tap fittings, designed for three or five tapholes (only for the model 120x47 942411). Wall-hung or countertop installation / Waschtisch mit Überlauf und Einlocharmatur, geeignet für drei oder fünf Löcher (nur für Modell 120x47 942411). Für Wand- oder Aufsatzinstallation

Opzione colore / Color options / Faberoption

Bianco lucido

Installazione / Installation / Installation

Sospensione / Wall-hung / Wanshängend

Appoggio / Countertop / Aufsatzwaschbecken

120x47
942511



120x47
942411



extraglazeantibacterial®



120x47
Lavabo / Washbasin / Waschbecken

Lavabo con foro troppopieno e monoforo per rubinetteria, predisposto per tre fori o cinque fori (solo per modello 100x47 9423111). Installazione a sospensione o ad appoggio. Disponibile nelle finiture Color Elements Bianco Opaco e Cenere (solo per art. 9431111; art. 9430111) / Washbasin with overflow and single tap hole for tap fittings, designed for three tap holes or five tap holes (only for the model 100x47 9423111). Wall-hung or countertop installation. Available in Color Elements finishings Matt White and Cenere (only for art. 9431111; art. 9430111) / Waschtisch mit Überlauf und Einlocharmatur, geeignet für drei Löcher oder fünf Löchern (nur für Modell 100x47 9423111). Für Wand- oder Aufsatzinstallation. Erhältlich in den Ausführungen Color Elements Bianco matt und Cenere (nur für art. 9431111; art. 9430111)

Opzione colore/Color options/Faberoption

- Bianco lucido
- Bianco opaco (9431111/9430111)
- Ardesia (9431111/9430111)

Installazione/Installation/Installation

- Sospensione/Wall-hung/Wanshängend
- Appoggio/Countertop/Aufsatzwaschbecken

100x47
9423111



80x47
9422111



60x47
9431111



50x47
9430111



Solo per /
Only for /
Nur für
Bianco lucido



extraglazeantibacterial®



100x47
Lavabo / Washbasin / Waschbecken

168 Lavabo con foro troppopieno e monoforo per rubinetteria, predisposto per tre fori. Installazione a sospensione o ad appoggio / Washbasin with overflow and single taphole for tap fittings, designed for three tapholes. Wall-hung or countertop installation / Waschtisch mit Überlauf und Einlocharmatur, geeignet für drei Löcher. Für Wand-oder Aufsatzinstallation

Opzione colore / Color options / Faberoption

Bianco lucido

Installazione / Installation / Installation

Sospensione / Wall-hung / Wanshängend

Appoggio / Countertop / Aufsatzwaschbecken

120x47
945211



100x47
945111



extraglazeantibacterial®



100x47
Lavabo / Washbasin / Waschbecken

170 Lavabo con foro troppopieno e monoforo per rubinetteria, predisposto per tre fori. Versione con piano ceramico laterale destro o sinistro.
 Installazione a sospensione o ad appoggio /
 Washbasin with overflow and single taphole for tap fittings, designed for three tapholes. Model with ceramic side counter on left or right side.
 Wall-hung or countertop installation /
 Waschtisch mit Überlauf und Hahnlochbefestigung für drei Löcher. Version mit seitliche Keramikfläche rechts oder links. Für Wand- oder Aufsatzinstallation

Opzione colore / Color options / Faberoption

Bianco lucido

Installazione / Installation / Installation

Sospensione / Wall-hung / Wanshängend

Appoggio / Countertop / Aufsatzwaschbecken

80×47
9456111



80×47
9457111



 extraglazeantibacterial®



80×47
 Lavabo / Washbasin / Waschbecken

Lavabo con foro troppopieno e monoforo per rubinetteria, predisposto per tre fori. Installazione a sospensione o ad appoggio. Disponibile nelle finiture Color Elements Bianco opaco e Ardesia (solo per modello 45x35 9485111) / Washbasin with overflow and single taphole for tap fittings, designed for three tapholes. Wall-hung or countertop installation. Available in Color Elements finishings Matt White and Ardesia (only for the model 45x35 9485111) / Waschtisch mit Überlauf und Hahnlochbefestigung für drei Löcher. Für Wand- oder Aufsatzinstallation. Erhältlich in den Ausführungen Color Elements Bianco matt und Ardesia (nur für Modell 45x35 9485111)

Opzione colore / Color options / Faberoption

- Bianco lucido
- Bianco opaco (9851111)
- Ardesia (9851111)

Installazione / Installation / Installation

- Sospensione / Wall-hung / Wanshängend
- Appoggio / Countertop / Aufsatzwaschbecken

70x37
9455111



60x37
9454111



50x37
9447111



45x35
9485111



Solo per /
Only for /
Nur für
Bianco lucido



extraglazeantibacterial®

50x37
Lavabo / Washbasin / Waschbecken



Lavabo senza foro troppopieno predisposto per rubinetteria monoforo laterale. Installazione sospesa (con fori laterali posteriori per l'aggancio a parete) o ad appoggio (con tutti i lati a vista smaltati). Disponibile nelle finiture Color Elements / Washbasin without overflow, designed for single lateral taphole. Installation wall-hung (with rear lateral holes for wall fitting) or countertop (with all visible surfaces glazed). Available in Color Elements finishings / Waschtisch ohne Überlauf, geeignet für seitliche Hahnlochbefestigung. Wandinstallation (mit seitlichen hinten angebrachten Öffnungen für Wandaufhängung) oder Aufsatzinstallation (alle Sichtseiten glasiert) Erhältlich in den Color Elements-Ausführungen

Opzione colore/Color options/Faberoption

- | | |
|-------------------------------------|--------------------------------|
| <input type="radio"/> Bianco lucido | <input type="radio"/> Creta |
| <input type="radio"/> Bianco opaco | <input type="radio"/> Ghiaccio |
| <input type="radio"/> Agave | <input type="radio"/> Tortora |
| <input type="radio"/> Ardesia | |
| <input type="radio"/> Bistro | |
| <input type="radio"/> Cenere | |

Installazione/Installation/Installation

- Sospensione/Wall-hung/Wanshängend
- Appoggio/Countertop/Aufsatzwaschbecken

50×25
9486011



40×23
9484011



Solo per /
Only for /
Nur für
Bianco lucido



extraglazeantibacterial®



40×23 Bianco opaco
Lavabo / Washbasin / Waschbecken

176 Lavabo senza foro troppopieno predisposto per rubinetteria a parete o su piano.
Installazione ad appoggio. Disponibile nelle finiture Color Elements /
Washbasin without overflow designed for wall or countertop tap fittings.
Installation countertop. Available in Color Element finishings /
Waschtisch ohne Überlauf, geeignet für Wand- oder Standarmaturen. Aufge-
setzte Installation. Erhältlich in den Ausführungen Color Elements

Opzione colore / Color options / Faberoption

- | | |
|-------------------------------------|--------------------------------|
| <input type="radio"/> Bianco lucido | <input type="radio"/> Creta |
| <input type="radio"/> Bianco opaco | <input type="radio"/> Ghiaccio |
| <input type="radio"/> Agave | <input type="radio"/> Tortora |
| <input type="radio"/> Ardesia | |
| <input type="radio"/> Bistro | |
| <input type="radio"/> Cenere | |

Installazione / Installation / Installation

Appoggio / Countertop / Aufsatzwaschbecken

60x37
945311



50x37
942911



Solo per /
Only for /
Nur für
Bianco lucido



extraglazeantibacterial®



60x37 Ardesia
Lavabo / Washbasin / Waschbecken

178 Lavabo senza foro troppopieno predisposto per rubinetteria a parete o su piano.
 Installazione ad appoggio. Disponibile nelle finiture Color Elements /
 Washbasin without overflow designed for wall or countertop tap fittings.
 Installation countertop. Available in Color Element finishings /
 Waschtisch ohne Überlauf, geeignet für Wand- oder Standarmaturen. Aufge-
 setzte Installation. Erhältlich in den Ausführungen Color Elements

Opzione colore / Color options / Faberoption

- Bianco lucido
- Creta
- Bianco opaco
- Ghiaccio
- Agave
- Tortora
- Ardesia
- Bistro
- Cenere

Installazione / Installation / Installation

Appoggio / Countertop / Aufsatzwaschbecken

60x37
945811



Ø45
942711



Ø40
942611



Ø32
943511



Solo per /
 Only for /
 Nur für
 Bianco lucido



60x37
 Lavabo / Washbasin / Waschbecken

180 Lavabo con foro troppopieno e monoforo per rubinetteria.
Installazione ad incasso /
Washbasin with overflow and single taphole for tap fittings.
Installation built-in /
Waschtisch mit Überlauf und Hahnlochbefestigung für drei Löcher.
Für Einbaumontage

Opzione colore / Color options / Faberoption

Bianco lucido

Installazione / Installation / Installation

Incasso / Built-in / Einbaumontage

70x46
943711



58x40
943311

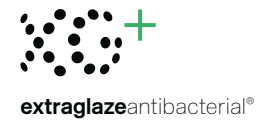

70x46
Lavabo / Washbasin / Waschbecken

182 Lavabo con foro troppopieno monoforo, predisposto per rubinetteria triforo.
Installazione a semincasso /
Washbasin with overflow, one taphole prearranged for three taphole fittings.
Semi-recessed installation /
Waschbecken mit Überlauf, ein Hahnloch, für drei Hahnlochbefestigungen.
Halbeinbaumontage

Opzione colore / Color options / Faberoption

Bianco lucido

Installazione / Installation / Installation

Semincasso / Semi-recessed / Halbeinbau

55x47
943411



55x47
Lavabo / Washbasin / Waschbecken



80x37
Lavabo / Washbasin / Waschbecken

Lavabo con foro troppopieno predisposto per rubinetteria a parete o su piano.
 Installazione sottopiano o ad incasso /
 Washbasin with overflow designed for wall or countertop tap fittings.
 Installation undercounter or built-in /
 Waschtisch mit Überlauf, geeignet für Wand- oder Standarmaturen.
 Für Unterbau- oder Einbaumontage

Opzione colore / Color options / Faberoption

Bianco lucido

Installazione / Installation / Installation

Sottopiano / Undercounter / Underbau

Incasso / Built-in / Einbaumontage

80x37
895411



60x37
895311



extraglazeantibacterial®



60x37
Lavabo / Washbasin / Waschbecken

Wc sospeso con sistema di scarico Swirlflush®.
 Bidet sospeso con foro troppopieno e monoforo per rubinetteria.
 Disponibili nelle finiture Color Elements Bianco opaco e Ardesia /
 Wall-hung wc with Swirlflush® flushing system.
 Wall-hung bidet with overflow and single taphole for tap fittings.
 Available in Color Elements finishings Matt White and Ardesia /
 WC in Wandaufhängung mit Spülsystem Swirlflush® Bidet wandhängend mit
 Überlauf und Hahnlochbefestigung. Erhältlich in den Ausführungen
 Color Elements Bianco matt und Ardesia

Opzione colore/Color options/Faberoption

- Bianco lucido
- Bianco opaco
- Ardesia

55x36/F
941511



55x36
946511



50x36/F
941611



50x36
946411



Solo per /
 Only for /
 Nur für
 Bianco lucido



extraglazeantibacterial®



swirlflush®



quickrelease



softclose



dualglaze

Solo per /
 Only for /
 Nur für
 Color elements



55x36/F
 Wc e bidet / Wc and bidet / Wc und Bidet

Opzione colore/Color options/Faberoption

Bianco lucido

46x35/F
941811



extraglazeantibacterial® swirlflush® quickrelease softclose



46x35/F
Wc

190 Wc in appoggio con sistema di scarico Swirlflush®, predisposto per scarico a parete o a pavimento tramite curva tecnica. Bidet in appoggio con foro troppopieno e monoforo per rubinetteria. Disponibile nelle finiture Color Elements Bianco opaco e Ardesia / Floor standing wc with Swirlflush® flushing system, designed for wall or floor outlet using S-curve plumbing. Floor standing bidet with overflow and one taphole for tap fittings Available in Color Elements finishings Matt White and Ardesia / WC zur aufgesetzten Installation mit Spülsystem Swirlflush®, geeignet für Wand- oder Bodeninstallation mithilfe eines Anschlussbogens. Bidet zur aufgesetzten Installation mit Überlauf und Hahnlochbefestigung Erhältlich in den Ausführungen Color Elements Bianco matt und Ardesia

Opzione colore/Color options/Faberoption

- Bianco lucido
- Bianco opaco
- Ardesia

55x36/F
941011



55x36
9462111



Solo per /
Only for /
Nur für
Bianco lucido



Solo per /
Only for /
Nur für
Color elements

55x36/F
Wc e bidet / Wc and bidet / Wc und Bidet



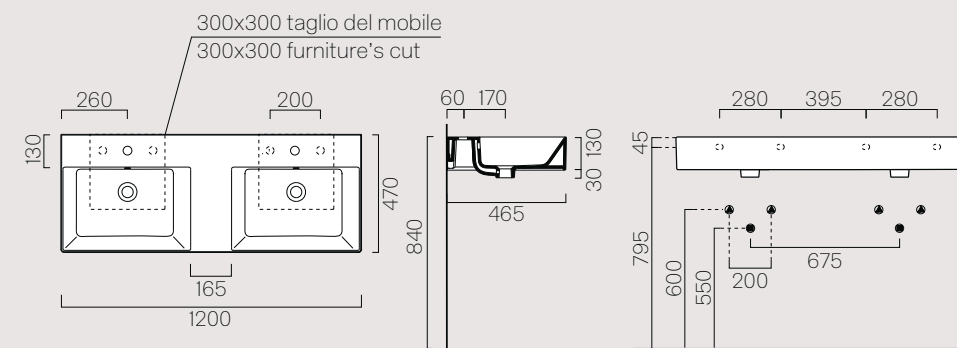

120x47
9425111

Description	Washbasin
Code	9425111
Dimensions	120x47 hi6
Capacity	Lt 5,5x2
Overflow	CL 25
Installation	Wall-hung, Countertop
Taphole	1 (3)

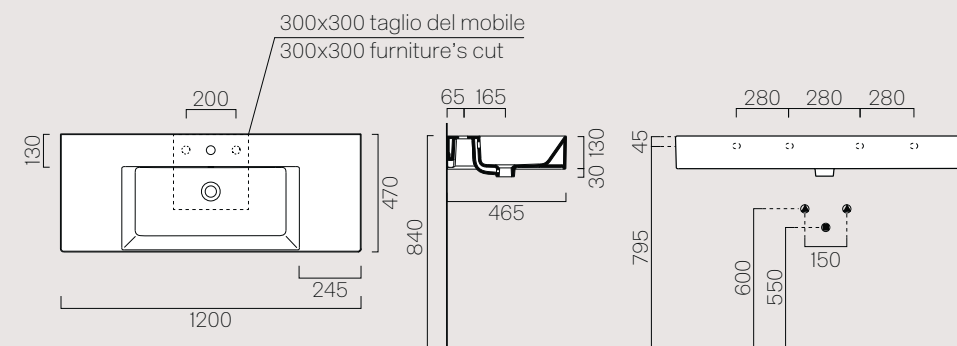

120x47
9452111

Description	Washbasin
Code	9452111
Dimensions	120x47 hi6
Weight	Kg 34,5
Capacity	Lt 9
Overflow	CL 25
Installation	Wall-hung, Countertop
Taphole	1 (3)

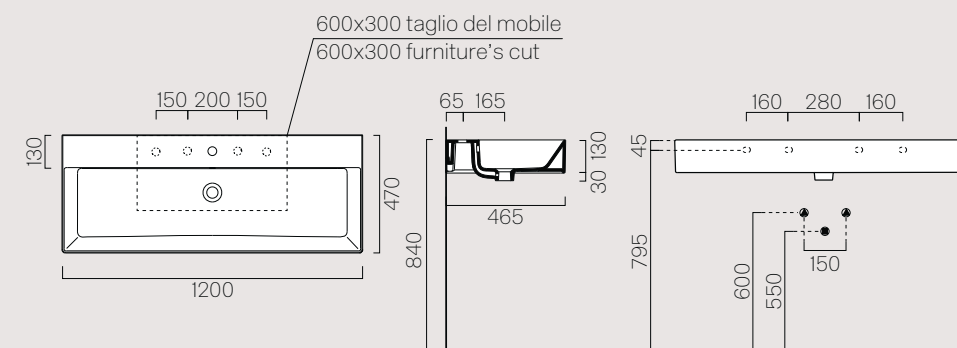

120x47
9424111

Description	Washbasin
Code	9424111
Dimensions	120x47 hi6
Weight	Kg 31,8
Capacity	Lt 16
Overflow	CL 25
Installation	Wall-hung, Countertop
Taphole	1 (5)

100x47
945111

Description	Washbasin
Code	945111
Dimensions	100x47 h16
Overflow	CL 25
Installation	Wall-hung, Countertop
Taphole	1(3)

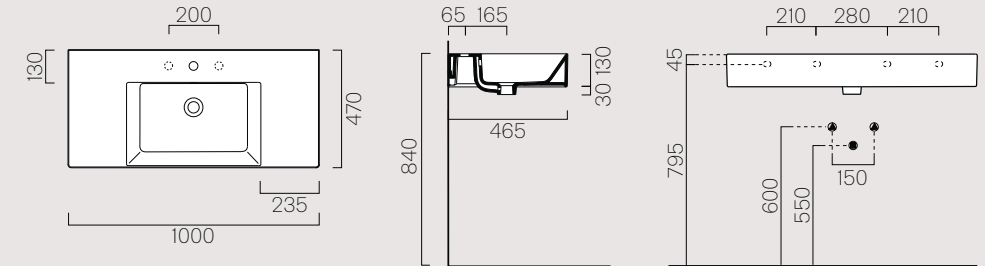

80x47
942211

Description	Washbasin
Code	942211
Dimensions	80x47 h16
Weight	Kg 22,8
Capacity	Lt 11
Overflow	CL 25
Installation	Wall-hung, Countertop
Taphole	1(3)

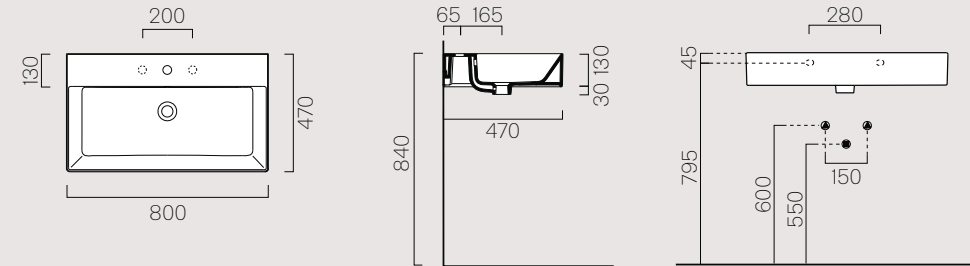

100x47
942311

Description	Washbasin
Code	942311
Dimensions	100x47 h16
Weight	Kg 28,5
Overflow	CL 25
Installation	Wall-hung, Countertop
Taphole	1(5)

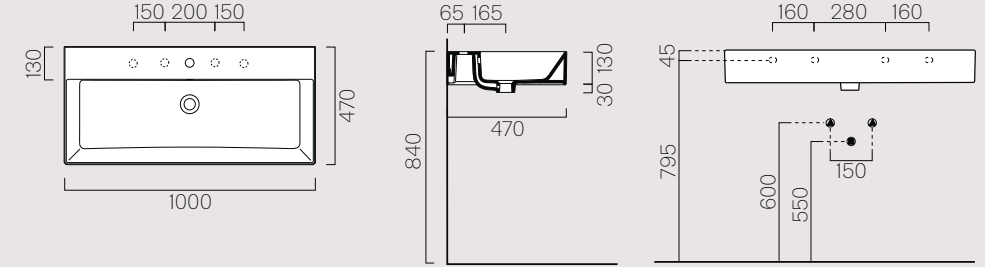

60x47
943111

Description	Washbasin
Code	943111
Dimensions	60x47 h16
Weight	Kg 17,2
Capacity	Lt 8
Overflow	CL 25
Installation	Wall-hung, Countertop
Taphole	1(3)

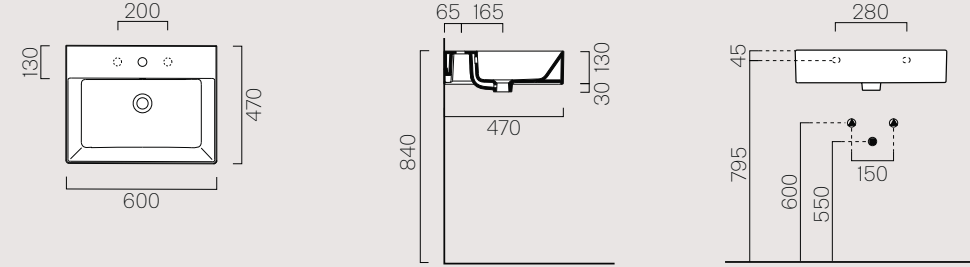

80x47
945611

Description	Washbasin
Code	945611
Dimensions	80x47 h16
Weight	Kg 22,9
Capacity	Lt 7
Overflow	CL 25
Installation	Wall-hung, Countertop
Taphole	1(3)

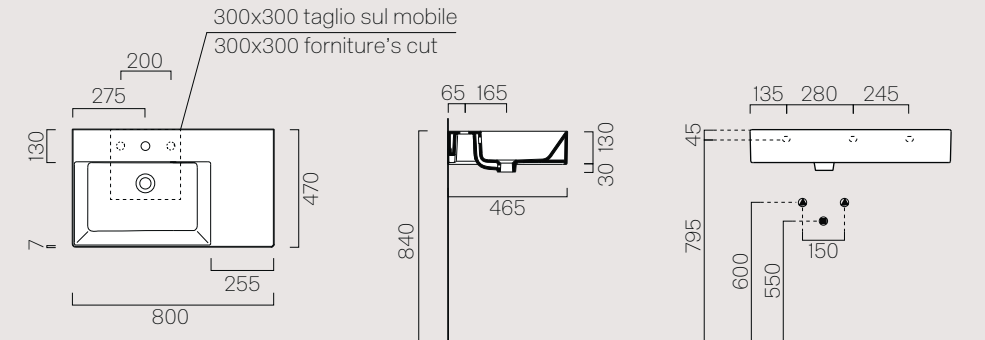

50x47
943011

Description	Washbasin
Code	943011
Dimensions	50x47 h16
Weight	Kg 15
Capacity	Lt 6
Overflow	CL 25
Installation	Wall-hung, Countertop
Taphole	1(3)

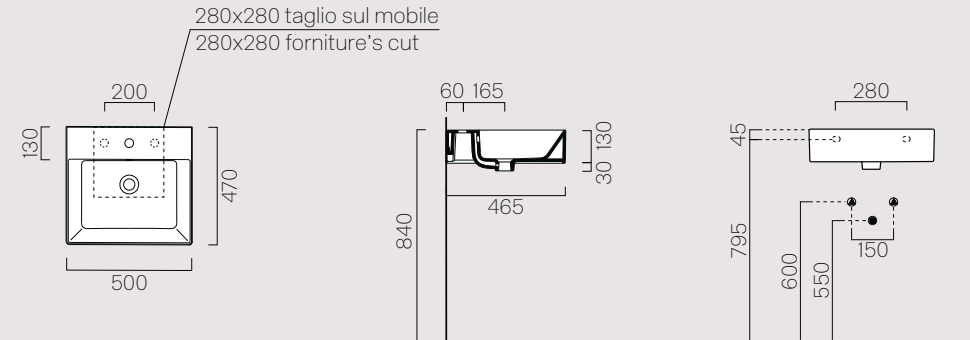

80x47
945711

Description	Washbasin
Code	945711
Dimensions	80x47 h16
Weight	Kg 22,9
Capacity	Lt 7
Overflow	CL 25
Installation	Wall-hung, Countertop
Taphole	1(3)

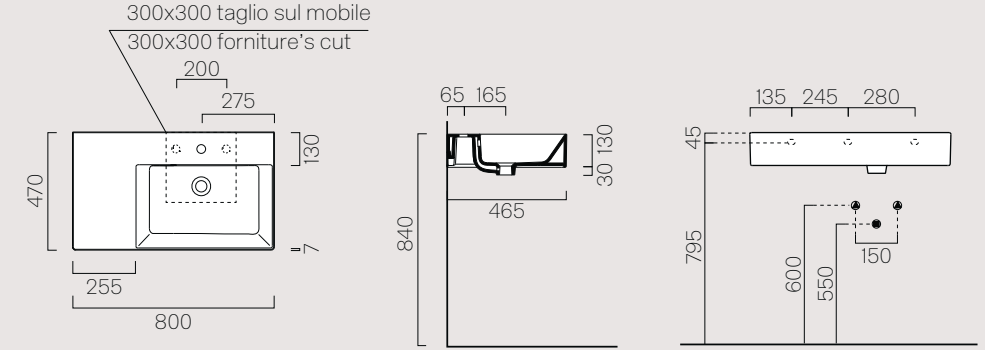

70x37
945511

Description	Washbasin
Code	945511
Dimensions	70x37 h16
Weight	Kg 17,3
Capacity	Lt 7
Overflow	CL 25
Installation	Wall-hung, Countertop
Taphole	1(3)

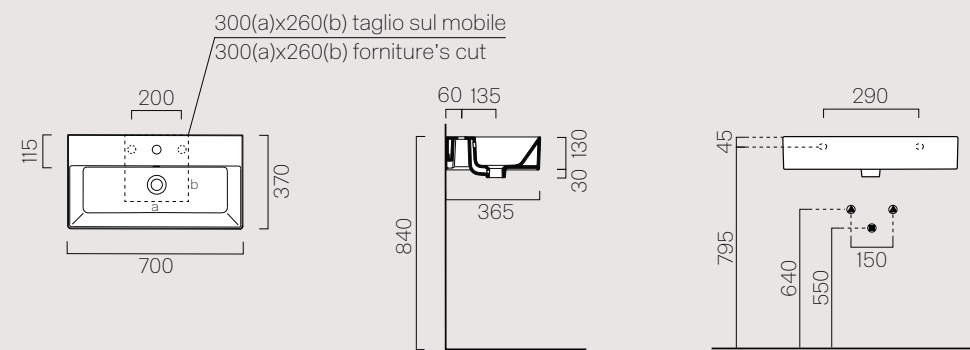

60x37 9454111

Description	Washbasin
Code	9454111
Dimensions	60x37 h16
Weight	Kg 13,8
Capacity	Lt 5,5
Overflow	CL 25
Installation	Wall-hung, Countertop
Taphole	1 (3)

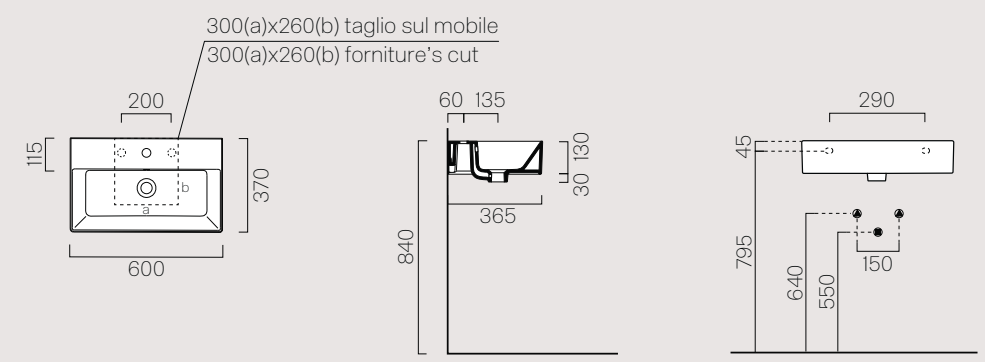

40x23 9484011

Description	Washbasin
Code	9484011
Dimensions	40x23 h11,5
Weight	Kg 7,4
Capacity	Lt 2,5
Overflow	CL 00
Installation	Wall-hung, Countertop
Taphole	0 (1)

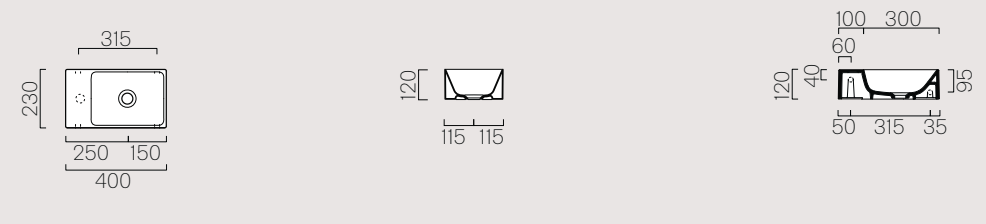

50x37 9447111

Description	Washbasin
Code	9447111
Dimensions	50x37 h16
Weight	Kg 12,3
Capacity	Lt 5
Overflow	CL 25
Installation	Wall-hung, Countertop
Taphole	1 (3)

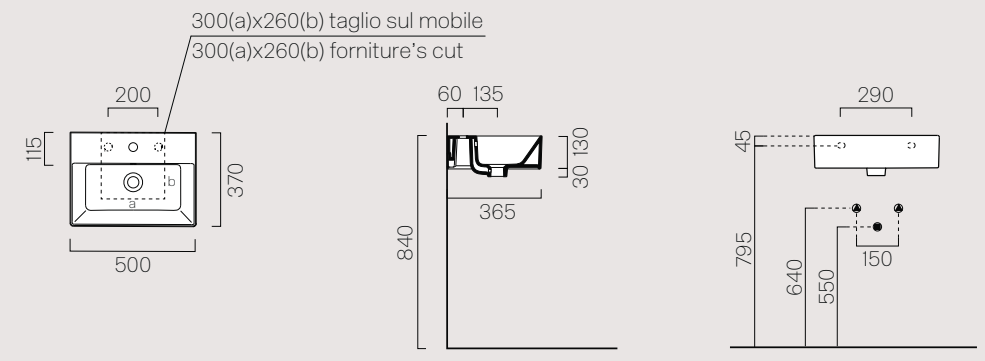

60x37 945311

Description	Washbasin
Code	945311
Dimensions	60x37 h13
Weight	Kg 14,2
Capacity	Lt 9
Overflow	CL 00
Installation	Countertop
Taphole	0

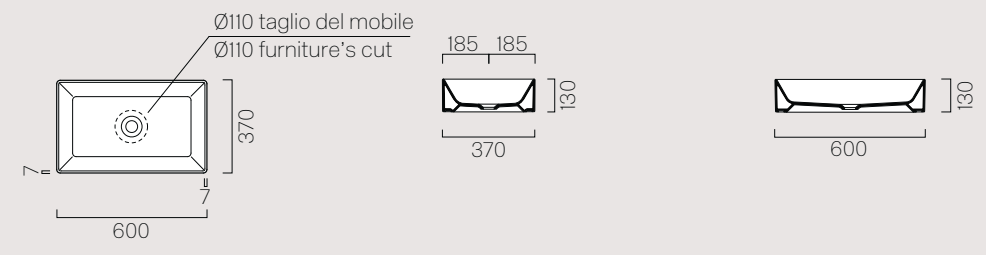

45x35 9485111

Description	Washbasin
Code	9485111
Dimensions	45x35 h13
Weight	Kg 9,8
Capacity	Lt 3,5
Overflow	CL 25
Installation	Wall-hung, Countertop
Taphole	1 (3)

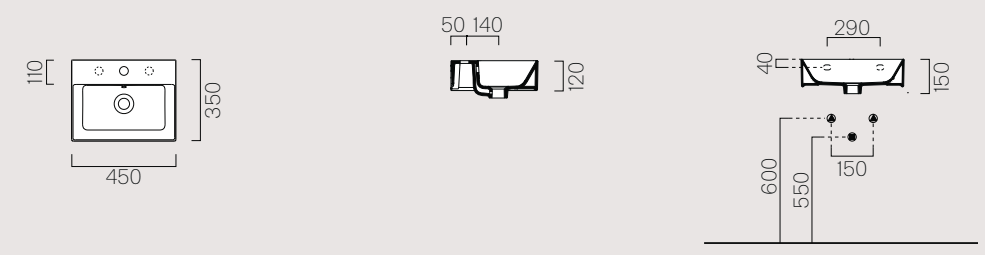

50x37 942911

Description	Washbasin
Code	942911
Dimensions	50x37 h13
Weight	Kg 11,5
Capacity	Lt 7
Overflow	CL 00
Installation	Countertop
Taphole	0

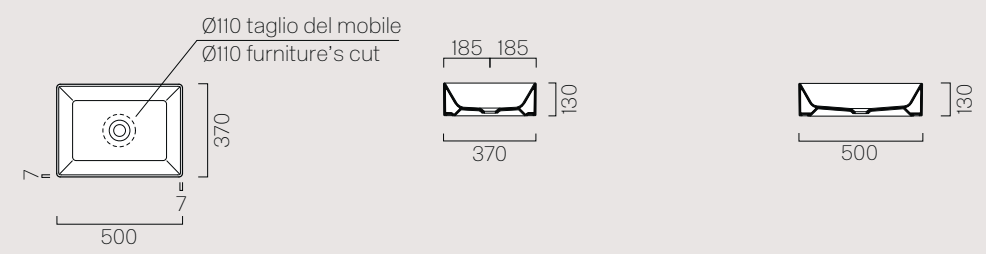

50x25 9486011

Description	Washbasin
Code	9486011
Dimensions	50x25 h13
Weight	Kg 9,1
Capacity	Lt 4
Overflow	CL 00
Installation	Wall-hung, Countertop
Taphole	0 (1)



60x37 945811

Description	Washbasin
Code	945811
Dimensions	60x37 h13
Weight	Kg 11,2
Overflow	CL 00
Installation	Countertop
Taphole	0

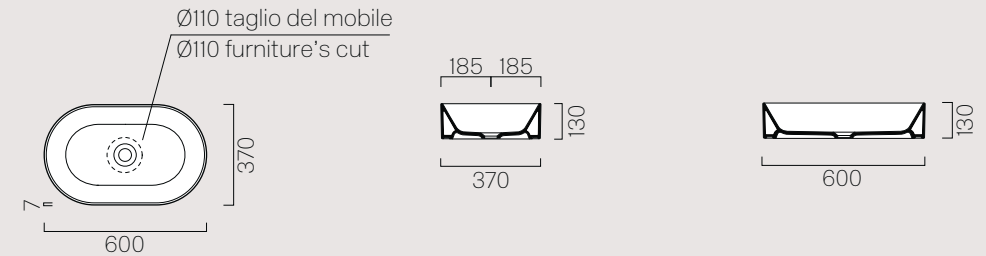

Ø45 942711

Description	Washbasin
Code	942711
Dimensions	Ø45
Overflow	CL 00
Installation	Countertop
Taphole	0



58×40 943311

Description	Washbasin
Code	943311
Dimensions	58×40 h16
Weight	Kg 10,8
Capacity	Lt 4,5
Overflow	CL 25
Installation	Built-in
Taphole	1

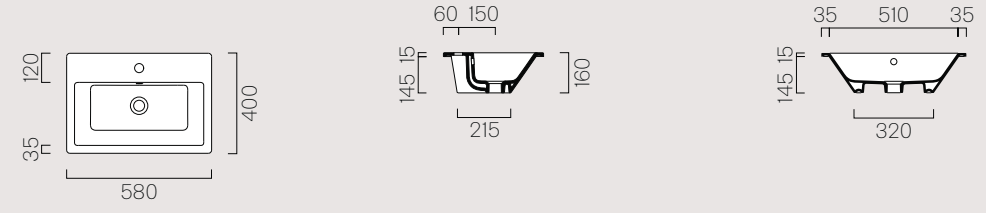

Ø40 942611

Description	Washbasin
Code	942611
Dimensions	Ø40
Overflow	CL 00
Installation	Countertop
Taphole	0



55×47 943411

Description	Washbasin
Code	943411
Dimensions	55×47 h16
Weight	Kg 15,4
Capacity	Lt 7
Overflow	CL 25
Installation	Semi-recessed
Taphole	1 (3)

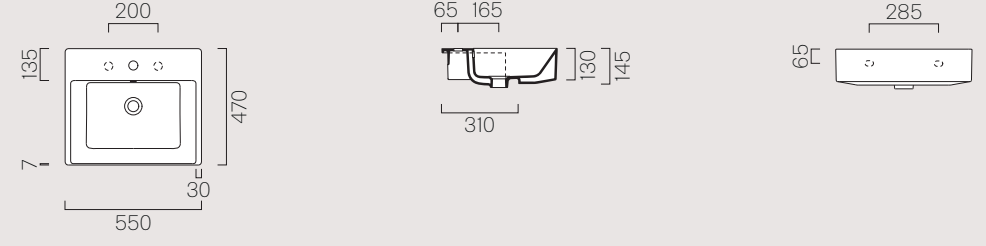

Ø32 943511

Description	Washbasin
Code	943511
Dimensions	Ø32
Weight	Kg 5,5
Capacity	Lt 3
Overflow	CL 00
Installation	Countertop
Taphole	0



80×37 895411

Description	Washbasin
Code	895411
Dimensions	80×37 h16
Weight	Kg 14,2
Capacity	Lt 7
Overflow	CL 25
Installation	Underplane, Built-in
Taphole	0

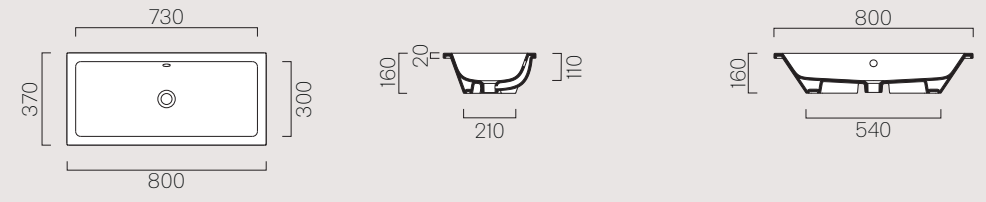

70×46 943711

Description	Washbasin
Code	943711
Dimensions	70×46 h16
Weight	Kg 14,8
Capacity	Lt 8
Overflow	CL 25
Installation	Built-in
Taphole	1

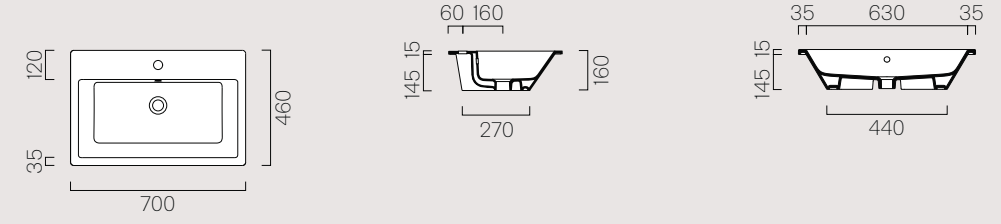

60×37 895311

Description	Washbasin
Code	895311
Dimensions	60×37 h16
Weight	Kg 10,5
Capacity	Lt 5
Overflow	CL 25
Installation	Underplane, Built-in
Taphole	0

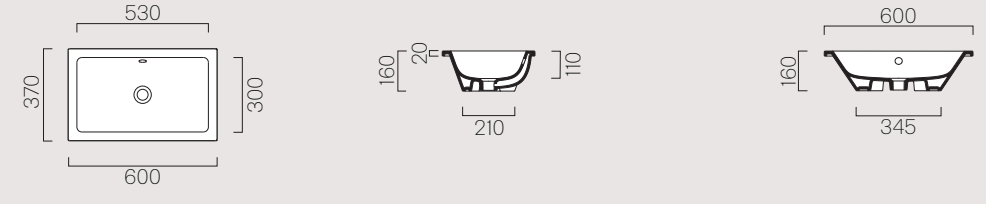

Wc e Bidet/Wc and Bidet/Wc und bidet

50×36
9464111

Description	Bidet
Code	9464111
Dimensions	50×36
Weight	Kg 15,6
Overflow	CL 25
Installation	Wall-hung
Taphole	1

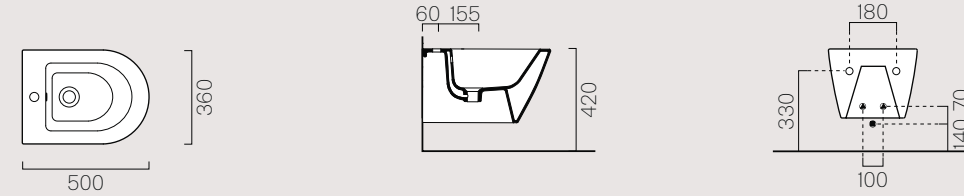

55×36/F
941511

Description	Wc
Code	941511
Dimensions	55×36
Weight	Kg 23,2
Flush system	Swirflush®
Installation	Wall-hung

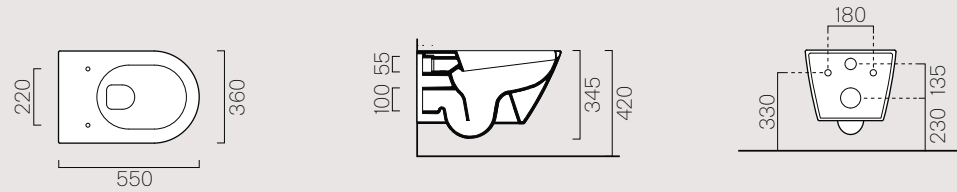

46×35/F
941811

Description	Wc
Code	941811
Dimensions	46×35
Weight	Kg 18,6
Flush system	Swirflush®
Installation	Wall-hung

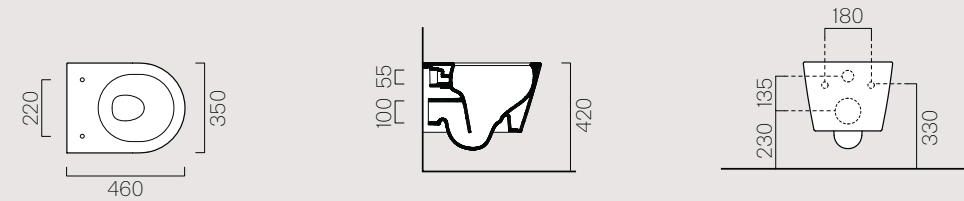

Non è consigliato l'impiego di cassette di scarico esterne o impianti dotati di rubinetto flussometro /
We do not recommend the use of external flushing cisterns or systems endowed with flushometer valves /
Empfohlen wird die Verwendung eines externen Spülkastens oder einer Selbstschlussarmatur

55×36
9465111

Description	Bidet
Code	9465111
Dimensions	55×36
Weight	Kg 17,9
Overflow	CL 25
Installation	Wall-hung
Taphole	1

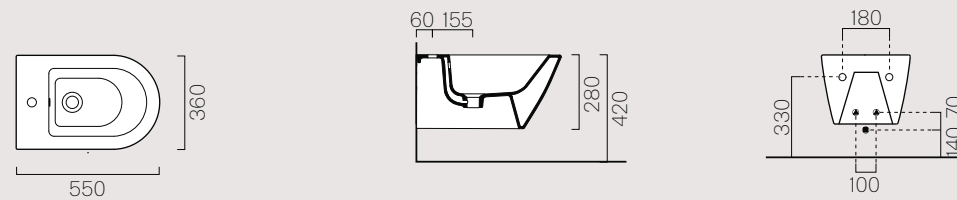

55×36/F
941011

Description	Wc
Code	941011
Dimensions	55×36
Weight	Kg 24,2
Flush system	Swirflush®
Installation	Floor standing

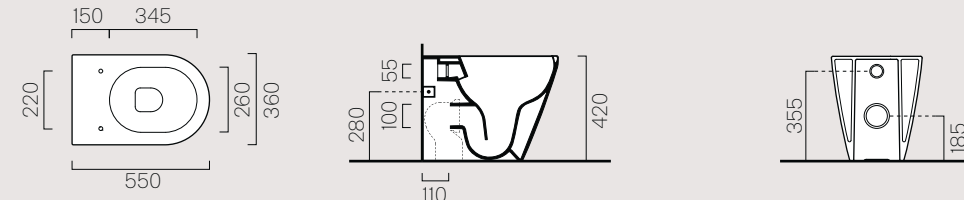

50×36/F
941611

Description	Wc
Code	941611
Dimensions	50×36
Weight	Kg 22
Flush system	Swirflush®
Installation	Wall-hung

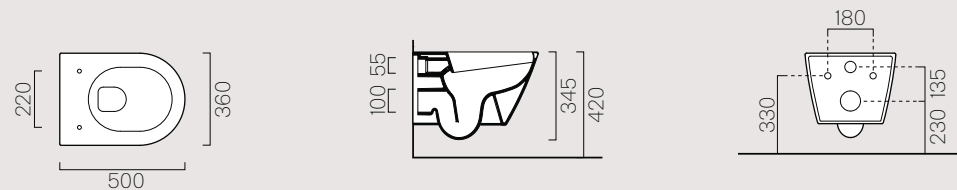

55×36
9462111

Description	Bidet
Code	9462111
Dimensions	55×36
Weight	Kg 21
Overflow	CL 25
Installation	Floor standing
Taphole	1

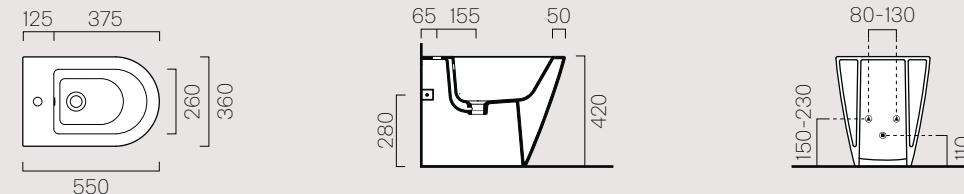

Non è consigliato l'impiego di cassette di scarico esterne o impianti dotati di rubinetto flussometro /
We do not recommend the use of external flushing cisterns or systems endowed with flushometer valves /
Empfohlen wird die Verwendung eines externen Spülkastens oder einer Selbstschlussarmatur



IT Le linee semplici e regolari di Norm si declinano in un ampio spettro di dimensioni che risponde alle diverse esigenze di spazio e personalizzazione. I bacini capienti, la predisposizione per l'aggiunta di portasciugamani, le molteplici possibilità di installazione, i diversi sistemi di accessori e arredi abbinabili, rendono Norm particolarmente performante ai fini contract. I sanitari dispongono di tutti gli speciali plus GSI.

EN Norm's simple and elegant lines come in a wide range of sizes to meet a variety of needs for space and personalization. Capacious washbasins, the possibility to add towel racks, the many installation options and the different sets of accessories and matchable fittings make Norm a high performance collection ideal for subcontracting. The sanitary elements all come with GSI's special extras.

DE Die schlichten und regelmäßigen Linien von Norm gliedern sich in ein breites Größen-Spektrum für die verschiedensten Platz. Und Personalisierungs-Anforderungen. Geräumige Becken, die Möglichkeit des Einbaus von Handtuchhaltern, die vielfältigen Einbaumöglichkeiten, die unterschiedlichen Systeme für Zubehör- und kombinierbare Ausstattungsmerkmale machen Norm besonders für Gewerbe- und Büroflächen interessant. Die Sanitärarmöbel bieten alle Plus-Specials von GSI.

100x50
Lavabo / Washbasin / Waschbecken

Norm

125×50
8627111
p.212



70×40
8637111
p.216



120×50
8626111
p.212



60×40
8636111
p.216



100×50
8633111
p.212



50×40
8638111
p.216



80×50
8634111
p.214



42×34
8685111
p.218



60×50
8635111
p.214



35×26
8650111
p.218



100×52
8643111
p.220



80×50
8644111
p.220



60×49
8645111
p.220



51×45
8646111
p.220



55×36/F
861511
8665111
p.222



55×36
861411
8662111
p.224



50×36/F
861611
8664111
p.222



68×36
861711
p.226





100x50
 Lavabo / Washbasin / Waschbecken

55x36/F
 Wc e bidet / Wc and bidet / Wc und Bidet



55x36
 Wc e bidet / Wc and bidet / Wc und Bidet

Nubes 185x90
 Vasca / Bathtub / Badewanne

80x50
 Lavabo / Washbasin / Waschbecken



55x36
 Wc e bidet / Wc and bidet / Wc und Bidet

100x52
 Lavabo / Washbasin / Waschbecken



125x50
Lavabo / Washbasin / Waschbecken

Lavabo con foro troppopieno e monoforo per rubinetteria, predisposto per tre fori o cinque fori (per versione 120x50 8626111). Installazione a sospensione o ad incasso /
Washbasin with overflow and single taphole for tap fittings, designed for three tapholes or five tapholes (for model 120x50 8626111). Installation wall-hung or built-in /
Waschtisch mit Überlauf und Hahnlochbefestigung, geeignet für drei oder fünf Löcher (für Version 120x47 8626111). Für Wand- oder Einbaumontage

Opzione colore / Color options / Faberoption

Bianco lucido

Installazione / Installation / Installation

Sospensione / Wall-hung / Wanshängend

Incasso / Built-in / Einbaumontage

125x50
8627111



120x50
8626111



100x50
8633111



extraglazeantibacterial®



120x50
Lavabo / Washbasin / Waschbecken

214 Lavabo con foro troppopieno e monoforo per rubinetteria, predisposto per tre fori. Installazione a sospensione o ad incasso / Washbasin with overflow and one taphole for tap fittings, designed for three tapholes. Wall-hung or built-in installation / Waschtisch mit Überlauf und Hahnlochbefestigung für drei Löcher. Für Wand- oder Einbaumontage

Opzione colore / Color options / Faberoption

Bianco lucido

Installazione / Installation / Installation

Sospensione / Wall-hung / Wanshängend

Incasso / Built-in / Einbaumontage

80x50
8634111



60x50
8635111



extraglazeantibacterial®



80x50
Lavabo / Washbasin / Waschbecken

216 Lavabo con foro troppopieno e monoforo per rubinetteria, predisposto per tre fori. Installazione a sospensione o ad incasso / Washbasin with overflow and single taphole for tap fittings, designed for three tapholes. Installation wall-hung or built-in / Waschtisch mit Überlauf und Hahnlochbefestigung, geeignet für drei. Für Wand- oder Einbaumontage

Opzione colore / Color options / Faberoption

Bianco lucido

Installazione / Installation / Installation

Sospensione / Wall-hung / Wanshängend

Incasso / Built-in / Einbaumontage

70×40
863711



60×40
863611



50×40
863811



extraglazeantibacterial®

217
Norm
70×40
Lavabo / Washbasin / Waschbecken



Opzione colore/Color options/Faberoption

Bianco lucido

Installazione/Installation/Installation

Sospensione/Wall-hung/Wanshängend

Incasso/Built-in/Einbaumontage

42x34
868511



35x26
865011



extraglazeantibacterial®



42x34
Lavabo / Washbasin / Waschbecken



Lavabo con foro troppopieno e monoforo per rubinetteria, predisposto per tre fori (per versione 100x52 8643111, 80x50 8644111, 60x49 8645111).
 Installazione a sospensione o ad incasso /
 Washbasin with overflow and one taphole for tap fittings, designed for three tapholes (for model 100x52 8643111, 80x50 8644111, 60x49 8645111).
 Wall-hung or built-in installation /
 Waschtisch mit Überlauf und Hahnlochbefestigung für drei Löcher (für version 100x52 8643111, 80x50 8644111, 60x49 8645111). Für Wand- oder Einbaumontage

Opzione colore /Color options /Faberoption

Bianco lucido

Installazione /Installation /Installation

Sospensione /Wall-hung /Wanshängend

Incasso /Built-in /Einbaumontage

60x49
Lavabo / Washbasin / Waschbecken

100x52
8643111



80x50
8644111



60x49
8645111



51x45
8646111



100x52
Lavabo / Washbasin / Waschbecken

222 Wc sospeso con sistema di scarico Swirlflush®. Bidet sospeso con foro troppopieno e monoforo per rubinetteria / Wall-hung wc with Swirlflush® flushing system. Wall-hung bidet with overflow and one taphole for tap fittings / WC wandhängend mit Spülsystem Swirlflush® Bidet wandhängend mit Überlauf und Hahnlochbefestigung

Opzione colore / Color options / Faberoption

Bianco lucido

55x36/F
861511



55x36
8665111



50x36/F
861611



50x36
8664111



extraglazeantibacterial®



swirlflush®



quickrelease



softclose



55x36/F
Wc e bidet / Wc and bidet / Wc und Bidet

224 Wc in appoggio predisposto per scarico a parete oppure a pavimento tramite curva tecnica. Bidet in appoggio con foro troppopieno e monoforo per rubinetteria / Floor standing wc designed for wall or floor outlet using S-curve plumbing. Floor standing bidet with overflow and single taphole for tap fittings / WC zur Aufsatzinstallation, geeignet für horizontalen und Bodenablauf mithilfe eines Anschlussbogens. Bidet zur aufgesetzten Installation mit Überlauf und Hahnlochbefestigung

Opzione colore / Color options / Faberoption

Bianco lucido

55x36
861411



55x36
8662111



extraglazeantibacterial®



save water



quickrelease



softclose

55x36
Wc e bidet / Wc and bidet / Wc und Bidet

226 Wc monoblocco con scarico a parete trasformabile a pavimento tramite curva tecnica non a corredo. Disponibile con cassetta accoppiata in duplice versione con o senza coperchio di chiusura / Close-coupled wc with wall outlet modifiable to floor outlet using the S-curve plumbing not included in set. Available with coupled water eistern with or without a lid / Monoblock-WC mit horizontalem Ablauf mittels (nicht mitgeliefertem Anschlussbogens) auch zu Bodenablauf umfunktionierbar. Erhältlich mit verbundener Spülkasten in zweifacher Ausführung mit oder ohne Deckel

Opzione colore/Color options/Faberoption

Bianco lucido

68×36^a
861711



68×36^b
861711



extraglazeantibacterial®



quickrelease



softclose

68×36
Wc

55×36
Bidet

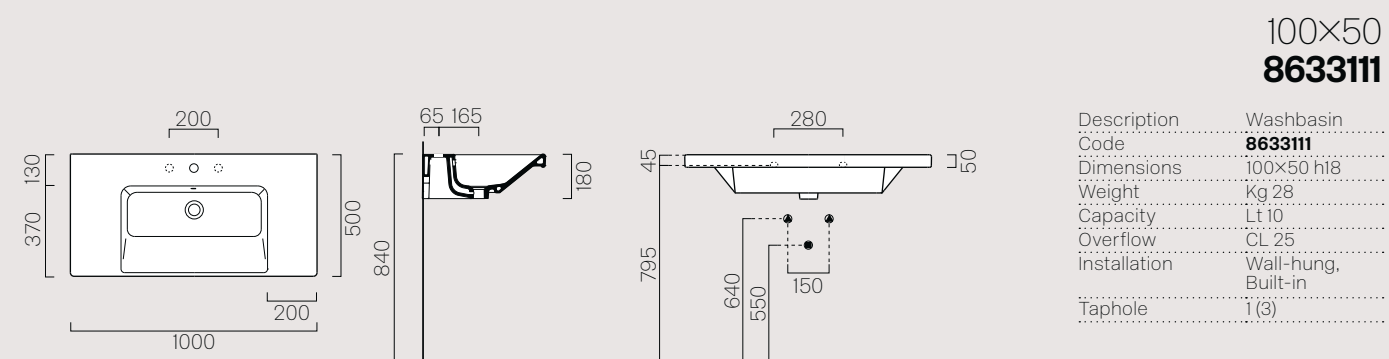
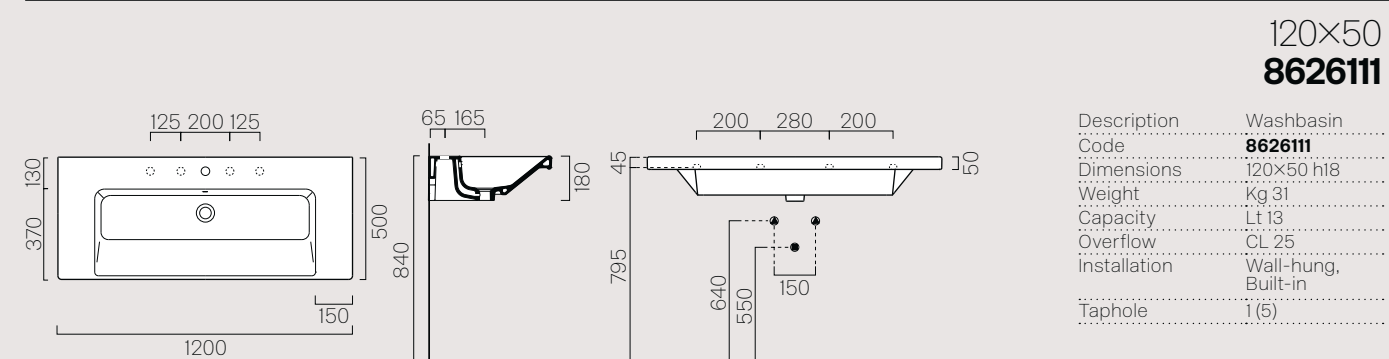
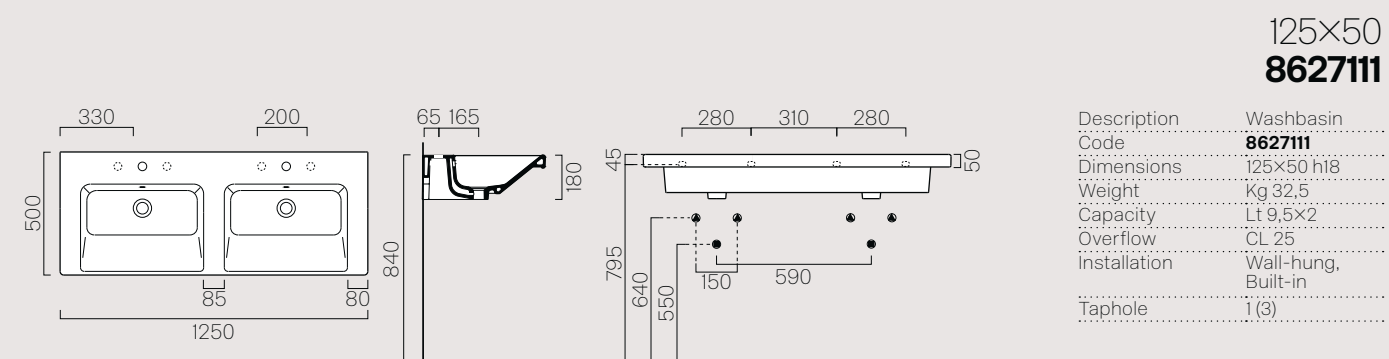

80×50 8634111

Description	Washbasin
Code	8634111
Dimensions	80×50 h18
Weight	Kg 23
Capacity	Lt 9,5
Overflow	CL 25
Installation	Wall-hung, Built-in
Taphole	1(3)

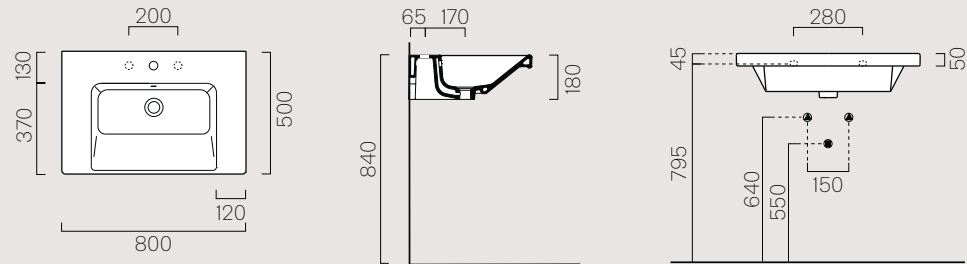

50×40 8638111

Description	Washbasin
Code	8638111
Dimensions	50×40 h18
Weight	Kg 12
Capacity	Lt 4
Overflow	CL 25
Installation	Wall-hung, Built-in
Taphole	1(3)

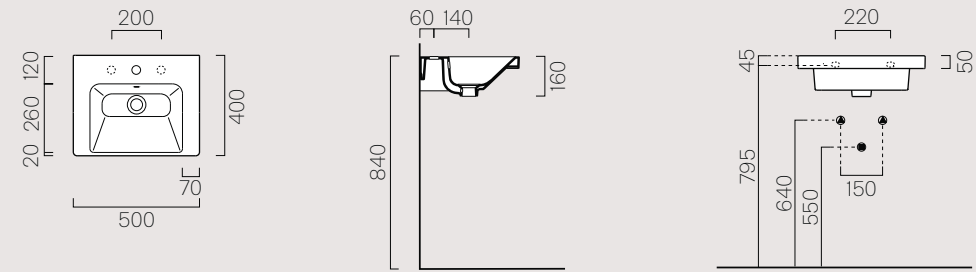

60×50 8635111

Description	Washbasin
Code	8635111
Dimensions	60×50 h18
Weight	Kg 18,4
Capacity	Lt 7
Overflow	CL 25
Installation	Wall-hung, Built-in
Taphole	1(3)

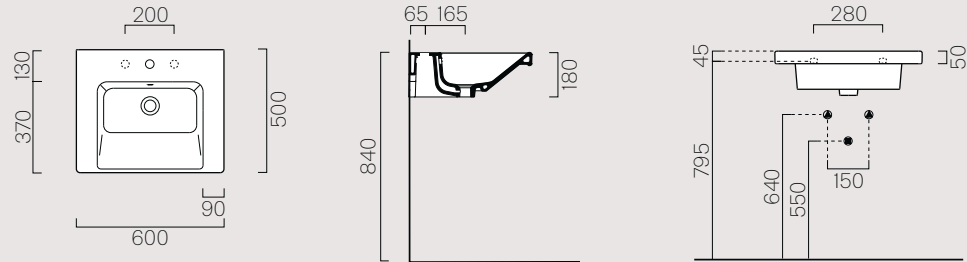

42×34 8685111

Description	Washbasin
Code	8685111
Dimensions	42×34 h17
Weight	Kg 8,6
Capacity	Lt 4
Overflow	CL 00
Installation	Wall-hung, Built-in
Taphole	1

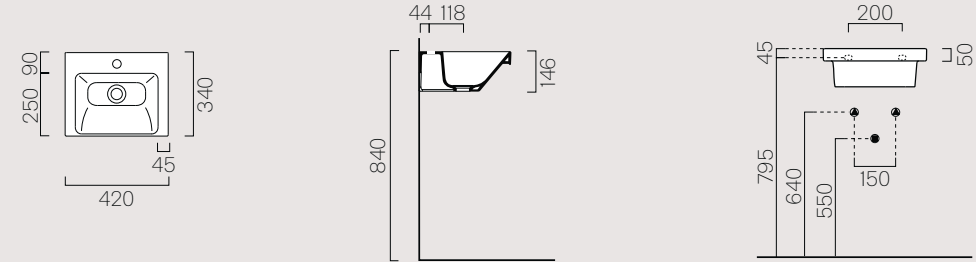

70×40 8637111

Description	Washbasin
Code	8637111
Dimensions	70×40 h18
Weight	Kg 15,7
Capacity	Lt 5
Overflow	CL 25
Installation	Wall-hung, Built-in
Taphole	1(3)

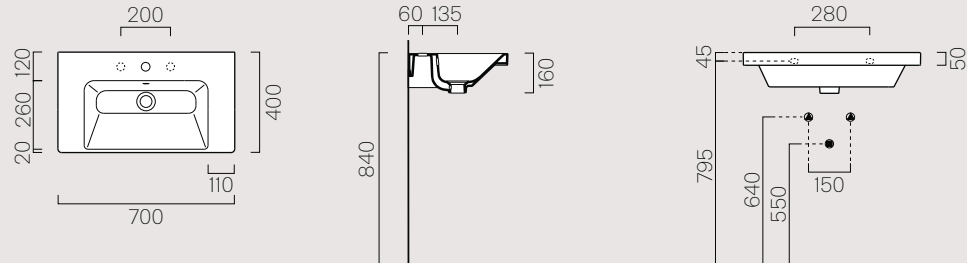

35×26 8650111

Description	Washbasin
Code	8650111
Dimensions	35×26 h12
Weight	Kg 5,6
Capacity	Lt 1,8
Overflow	CL 00
Installation	Wall-hung, Built-in
Taphole	1

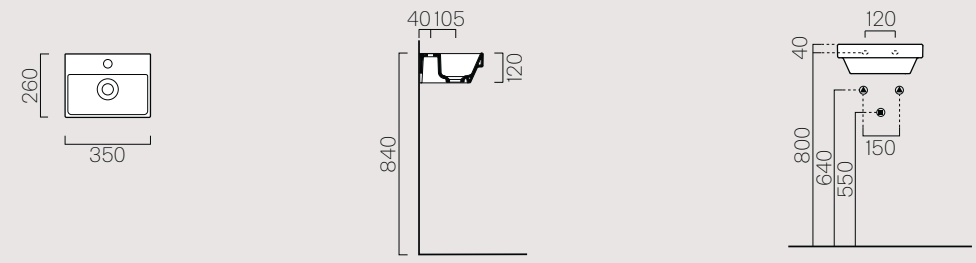

60×40 8636111

Description	Washbasin
Code	8636111
Dimensions	60×40 h18
Weight	Kg 15,3
Capacity	Lt 4
Overflow	CL 25
Installation	Wall-hung, Built-in
Taphole	1(3)

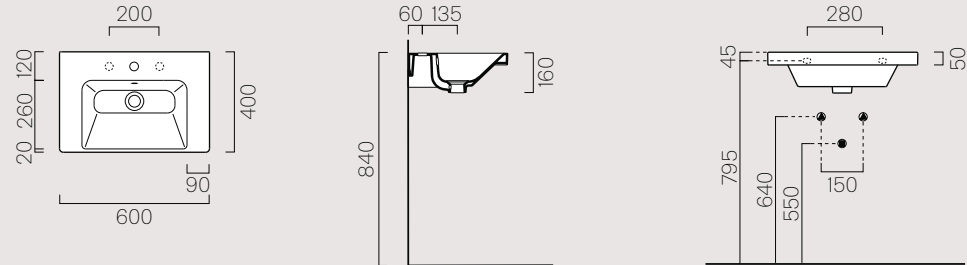

100×52 8643111

Description	Washbasin
Code	8643111
Dimensions	100×52 h18
Weight	Kg 22,5
Capacity	Lt 11
Overflow	CL 25
Installation	Wall-hung, Built-in
Taphole	1(3)

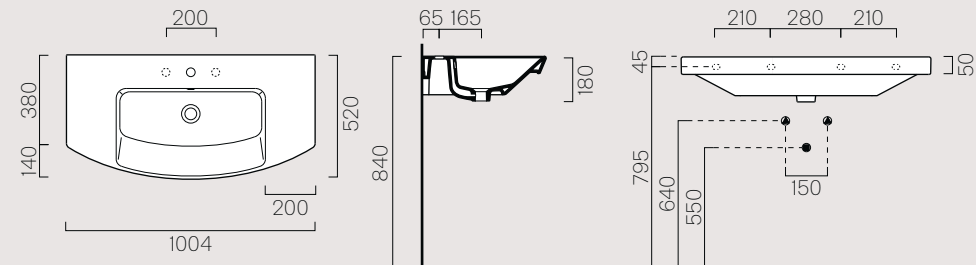

80×50 8644111

Description	Washbasin
Code	8644111
Dimensions	80×50 h18
Weight	Kg 17,8
Capacity	Lt 8
Overflow	CL 25
Installation	Wall-hung, Built-in
Taphole	1(3)

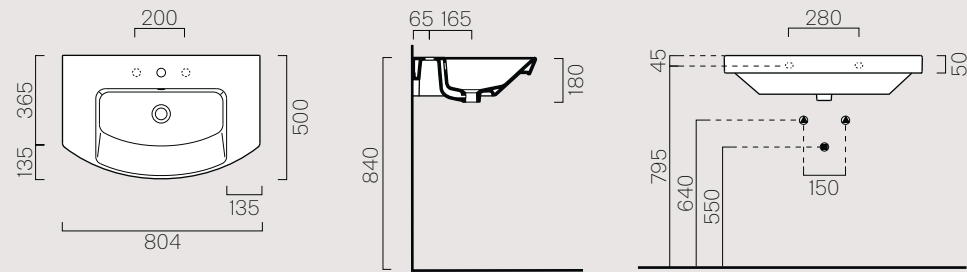

60×49 8645111

Description	Washbasin
Code	8645111
Dimensions	60×49 h18
Weight	Kg 14,2
Capacity	Lt 6
Overflow	CL 25
Installation	Wall-hung, Built-in
Taphole	1(3)

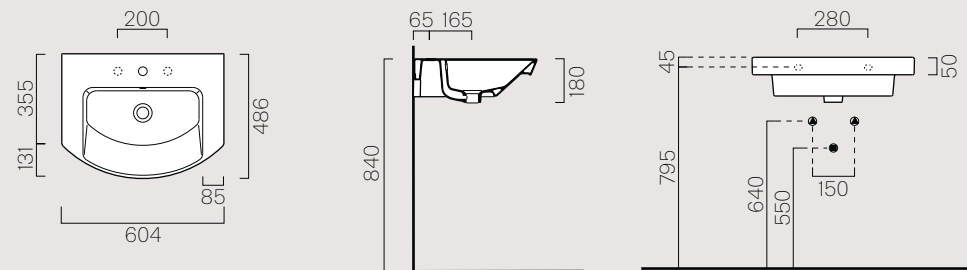

51×45 8646111

Description	Washbasin
Code	8646111
Dimensions	51×45 h18
Weight	Kg 11,4
Capacity	Lt 4,5
Overflow	CL 25
Installation	Wall-hung, Built-in
Taphole	1

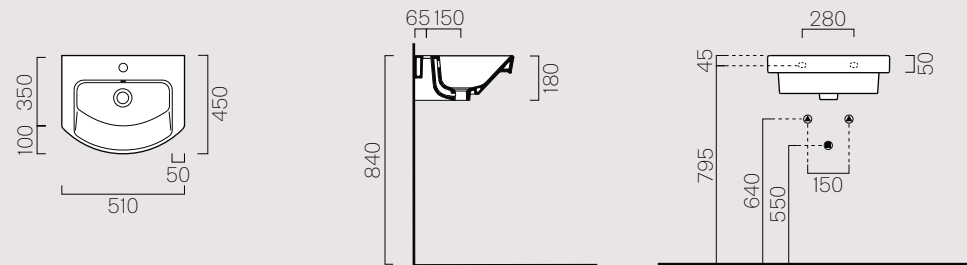

Wc e Bidet/Wc and Bidet/Wc und bidet

55×36/F 861511

Description	Wc
Code	8615111
Dimensions	55×36
Weight	Kg 23,7
Flush system	Swirflush®
Installation	Wall-hung

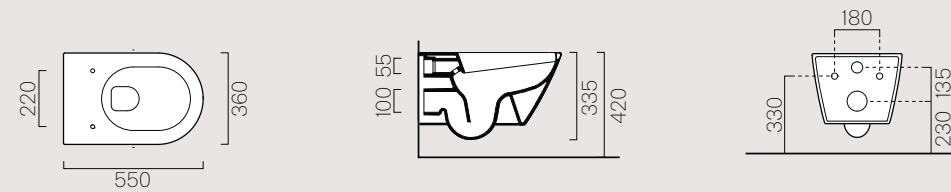

Non è consigliato l'impiego di cassette di scarico esterne o impianti dotati di rubinetto flussometro /
We do not recommend the use of external flushing cisterns or systems endowed with flushometer valves /
Empfohlen wird die Verwendung eines externen Spülkastens oder einer Selbstschlussarmatur

55×36 8665111

Description	Bidet
Code	8665111
Dimensions	55×36
Weight	Kg 16,3
Overflow	CL 25
Installation	Wall-hung
Taphole	1

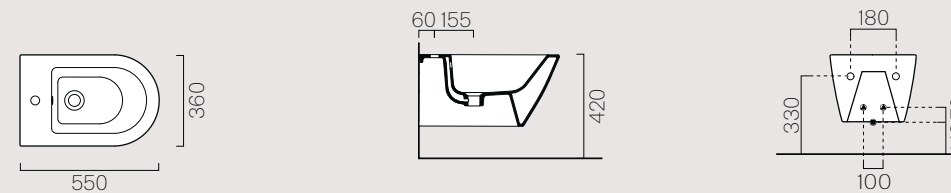

50×36/F 861611

Description	Wc
Code	8616111
Dimensions	50×36
Weight	Kg 22,3
Flush system	Swirflush®
Installation	Wall-hung

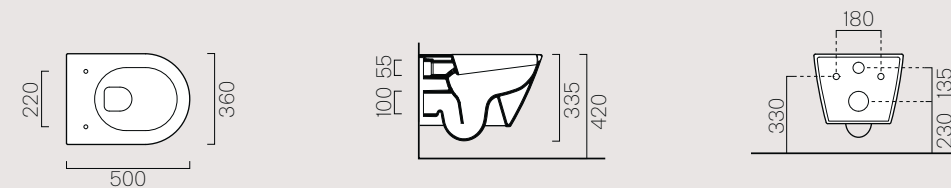

Non è consigliato l'impiego di cassette di scarico esterne o impianti dotati di rubinetto flussometro /
We do not recommend the use of external flushing cisterns or systems endowed with flushometer valves /
Empfohlen wird die Verwendung eines externen Spülkastens oder einer Selbstschlussarmatur

50x36
8664111

Description	Bidet
Code	8664111
Dimensions	50x36
Weight	Kg 15,3
Overflow	CL 25
Installation	Wall-hung
Taphole	1

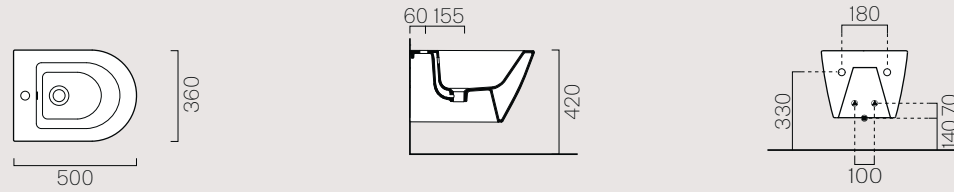

55x36
861411

Description	Wc
Code	861411
Dimensions	55x36
Weight	Kg 24,8
Flush system	Standard
Installation	Floor standing

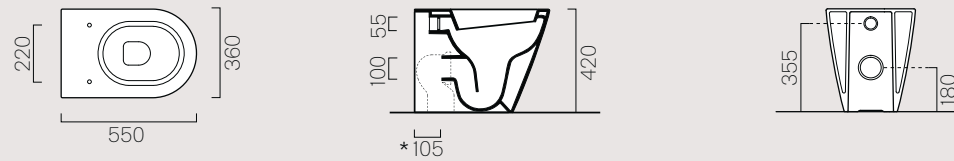

Curva tecnica /
Technical curve



Codice /
Codes

Interasse /
Distance

MCURVA

*105

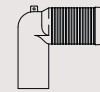

MCURVA90

*60

55x36
8662111

Description	Bidet
Code	8662111
Dimensions	55x36
Weight	Kg 20,8
Overflow	CL 25
Installation	Floor standing
Taphole	1

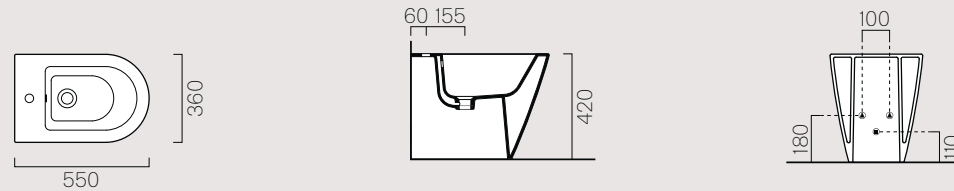

68x36
861711

Description	Wc
Code	861711
Dimensions	68x36
Weight	Kg 31,8
Flush system	Standard
Installation	Floor standing

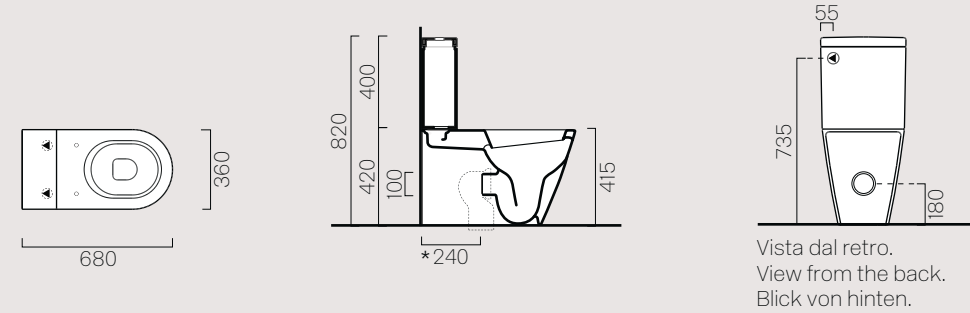

Vista dal retro.
View from the back.
Blick von hinten.

Curva tecnica /
Technical curve



Codice /
Codes

Interasse /
Distance

MCURVAS

*Da 230 a 305 mm
*From 230 to 305 mm



MCURVA90

*Da 80 a 205 mm
*From 80 to 205 mm

55x36
869111

Description	Ceramic Cover
Code	869111
Dimensions	13x35,5 46h
Weight	Kg 9,6

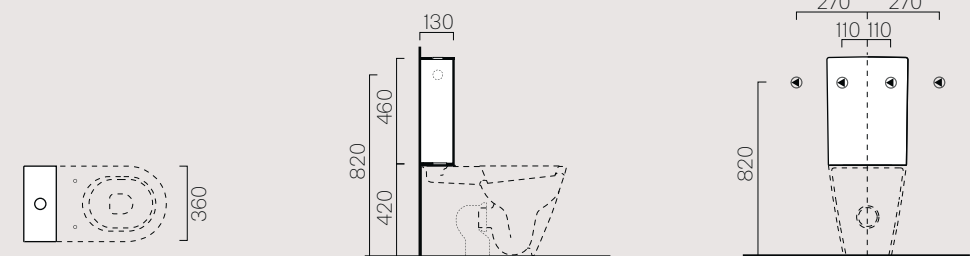

Cassetta/Cistern
868111

Description	Cistern
Code	868111
Dimensions	17x31 43h
Weight	Kg 13,5

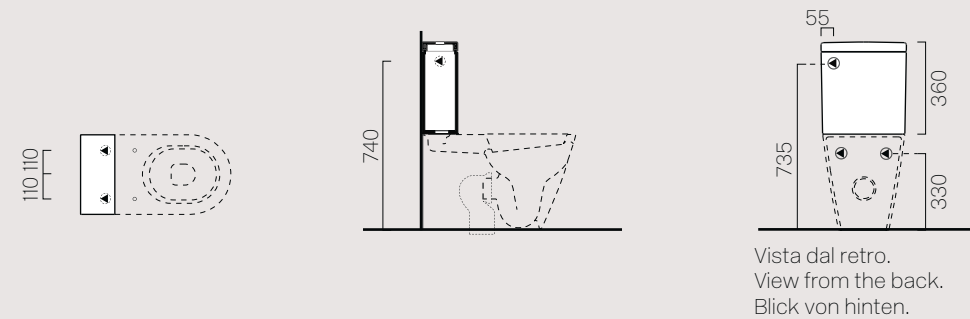

Vista dal retro.
View from the back.
Blick von hinten.



IT La collezione Pura si caratterizza per razionalità progettuale secondo i valori di semplicità e accuratezza che contraddistinguono GSI. Forme sobrie e spessori ultra sottili si combinano a morbidi arrotondamenti del bacino. Pura presenta anche una serie di lavabi da appoggio, disponibili nelle varianti di finiture Color Elements. I sanitari dispongono di tutti gli speciali plus GSI.

EN The Pura collection stands out for its rational design in keeping with the values of simplicity and precision that characterize GSI. Sober forms and ultra-slender edges accompany the supple curves of the washbasin. Pura also includes a set of countertop washbasins that are available in the various Color Elements finishes. Sanitary ware feature all the GSI extras.

DE Die Kollektion sticht durch planerische Rationalität, Sachlichkeit und Sorgfalt hervor, Werte, die GSI seit je her auszeichnen. Nüchterne Formen und hauchdünne Volumen verbinden sich hier mit den weichen Rundungen des Beckens. Pura beinhaltet auch eine Reihe von Aufsatz-Waschtischen in den verschiedenen Varianten der Color Elements-Ausführungen. Die Sanitärarmöbel bieten alle Plus-Specials von GSI.

38x38
Lavabo / Washbasin / Waschbecken

Pura

120×50
8845111
p.246



122×46
8840111
p.248



102×52
8825111
p.250



100×50
8844111
p.246



102×46
8833111
p.248



82×49
8826111
p.250



80×50
8843111
p.246



82×46
8838111
p.248



62×48
8827111
p.250



60×50
8836111
p.246



62×46
8839111
p.248



52×44
8830111
p.250



60×42
884211
p.252
p.92 →



60×37
883411
p.254
p.92 →



50×35
886011
p.254
p.92 →



Ø42
885111
p.256
p.94 →



Ø42
885511
p.256
p.94 →



Ø42 h22
885211
p.256
p.94 →



Ø32
885411
p.256
p.94 →



60×38
883711
p.258
p.96 →



50×38
884711
p.258
p.96 →



38×38
885011
p.258
p.96 →



Ø40
884611
p.258
p.96 →



55×38
724311
p.260



50×35
724711
p.260



55x36/F
881511
8865111

p.262
p.98 →



50x36/F
881611
8864111

p.262
p.100 →



55x36/F
881011
8862111

p.268
p.102 →



50x36/F
882011
8869111

p.268



68x38
881711

p.272



55x36/R
882111
8865111

p.264



55x36/R
880911
8862111

p.270



55x35/F
881111
8861111

p.266





55x36/F
 Wc e bidet / Wc and bidet / Wc und Bidet

60x42
 Lavabo / Washbasin / Waschbecken



55x36/F
 Wc e bidet / Wc and bidet / Wc und Bidet

102x52
 Lavabo / Washbasin / Waschbecken



100×50
Lavabo / Washbasin / Waschbecken

Lavabo con foro troppopieno e monoforo per rubinetteria, predisposto per tre fori. Installazione a sospensione o ad incasso / Washbasin with overflow and one taphole for tap fittings, designed for three tapholes. Wall-hung or built-in installation / Waschtisch mit Überlauf und Hahnlochbefestigung für drei Löcher. Für Wand- oder Einbaumontage

Opzione colore / Color options / Faberoption

Bianco lucido

Installazione / Installation / Installation

Sospensione / Wall-hung / Wanshängend

Incasso / Built-in / Einbaumontage

120×50
8845111



100×50
8844111



80×50
8843111



60×50
8836111



120×50
Lavabo / Washbasin / Waschbecken



82x46
Lavabo / Washbasin / Waschbecken

Lavabo con foro troppopieno e monoforo per rubinetteria predisposto per tre fori o cinque fori (nella versione 122x46 8840111). Installazione a sospensione o ad incasso /
Washbasin with overflow and single taphole for tap fittings designed for three tapholes or five tapholes (in the model 122x46 8840111). Wall-hung or built-in installation /
Waschtisch mit Überlauf und Hahnlochbefestigung, geeignet für drei oder fünf Löcher (in der Version 122x46 8840111). Für Wand- oder Einbaumontage

Opzione colore / Color options / Faberoption

Bianco lucido

Installazione / Installation / Installation

Sospensione / Wall-hung / Wanshängend

Incasso / Built-in / Einbaumontage

122x46
8840111



102x46
8833111



82x46
8838111



62x46
8839111



122x46
Lavabo / Washbasin / Waschbecken

250 Lavabo con foro troppopieno e monoforo per rubinetteria, predisposto per tre fori. Installazione a sospensione o ad incasso / Washbasin with overflow and one taphole for tap fittings, designed for three tapholes. Wall-hung or built-in installation / Waschtisch mit Überlauf und Hahnlochbefestigung für drei Löcher. Für Wand- oder Einbaumontage

Opzione colore / Color options / Faberoption

Bianco lucido

Installazione / Installation / Installation

Sospensione / Wall-hung / Wanshängend

Incasso / Built-in / Einbaumontage

102×52
882511



82×49
882611



62×48
882711



52×44
883011



extraglazeantibacterial®

102×52
Lavabo / Washbasin / Waschbecken





60x42
Lavabo / Washbasin / Waschbecken

252 Lavabo senza foro troppopieno predisposto per rubinetteria a parete e su piano.
Installazione ad appoggio. Disponibile nelle finiture Color Elements /
Washbasin without overflow designed for wall or countertop tap fittings.
Countertop installation. Available in Color Elements finishings /
Waschtisch ohne Überlauf, geeignet für Wand- und Standarmaturen.
Aufgesetzte Installation. Erhältlich in den Ausführungen Color Elements

Opzione colore / Color options / Faberoption

- | | |
|-------------------------------------|--------------------------------|
| <input type="radio"/> Bianco lucido | <input type="radio"/> Creta |
| <input type="radio"/> Bianco opaco | <input type="radio"/> Ghiaccio |
| <input type="radio"/> Agave | <input type="radio"/> Tortora |
| <input type="radio"/> Ardesia | |
| <input type="radio"/> Bistro | |
| <input type="radio"/> Cenere | |

Installazione / Installation / Installation

Appoggio / Countertop / Aufsatzwaschbecken

60x42
884211



Solo per /
Only for /
Nur für
Bianco lucido



extraglazeantibacterial®

254 Lavabo senza foro troppopieno predisposto per rubinetteria a parete e su piano.
 Installazione ad appoggio. Disponibile nelle finiture Color Elements /
 Washbasin without overflow designed for wall or countertop tap fittings.
 Countertop installation. Available in Color Elements finishings /
 Waschtisch ohne Überlauf, geeignet für Wand- und Standarmaturen.
 Aufgesetzte Installation. Erhältlich in den Ausführungen Color Elements

Opzione colore / Color options / Faberoption

- | | |
|--|--|
|  Bianco lucido |  Creta |
|  Bianco opaco |  Ghiaccio |
|  Agave |  Tortora |
|  Ardesia | |
|  Bistro | |
|  Cenere | |

Installazione / Installation / Installation

 Appoggio / Countertop / Aufsatzwaschbecken

60x37
883411



50x35
886011



Solo per /
 Only for /
 Nur für
 Bianco lucido



55x36/R
 Wc

60x37
 Lavabo / Washbasin / Waschbecken

256 Lavabo senza foro troppopieno predisposto per rubinetteria a parete e su piano.
 Lavabo con troppopieno nella versione Ø42 art. 885511. Installazione ad appoggio.
 Disponibile nelle finiture Color Elements /
 Washbasin without overflow designed for wall or countertop tap fittings.
 Washbasin with overflow in the model Ø42 art. 885511. Countertop installation.
 Available in Color Elements finishings /
 Waschtisch ohne Überlauf, geeignet für Wand- und Standarmaturen.
 Waschtisch mit Überlauf in der Version Ø42 art. 885511. Aufgesetzte Installation.
 Erhältlich in den Ausführungen Color Elements

Opzione colore / Color options / Faberoption

- | | |
|-------------------------------------|--------------------------------|
| <input type="radio"/> Bianco lucido | <input type="radio"/> Creta |
| <input type="radio"/> Bianco opaco | <input type="radio"/> Ghiaccio |
| <input type="radio"/> Agave | <input type="radio"/> Tortora |
| <input type="radio"/> Ardesia | |
| <input type="radio"/> Bistro | |
| <input type="radio"/> Cenere | |

Installazione / Installation / Installation

 Appoggio / Countertop / Aufsatzwaschbecken

Ø42
885111



Ø42
885511



Ø42 h22
885211



Ø32
885411



Solo per /
Only for /
Nur für
Bianco lucido



extraglaze antibacterial®

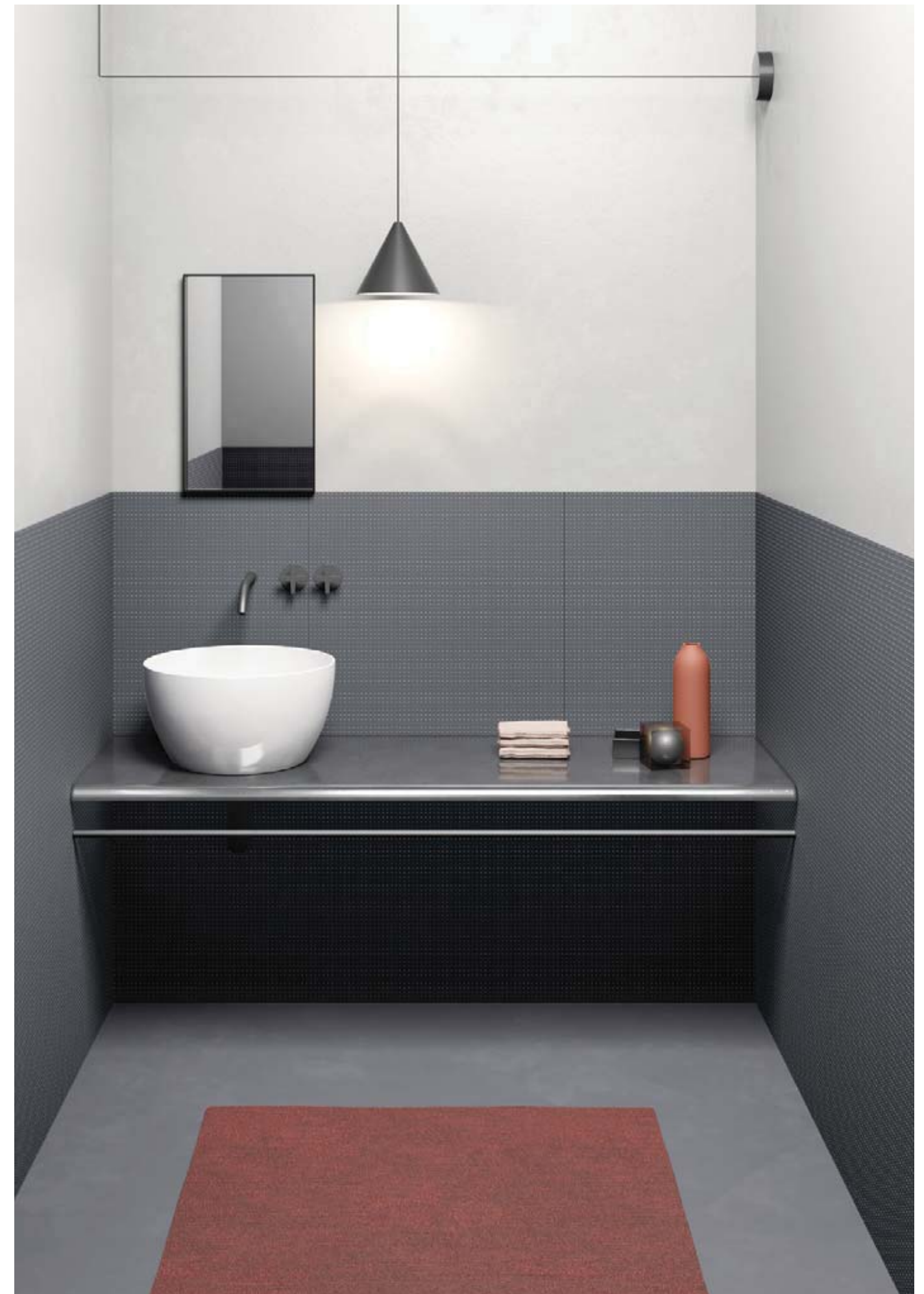

Ø42 h22
Lavabo / Washbasin / Waschbecken



Ø40 Ghiaccio
Lavabo / Washbasin / Waschbecken

Lavabo senza foro troppopieno, predisposto per rubinetteria a parete o su piano.
Installazione ad appoggio o ad incasso. Disponibile nelle finiture Color Elements /
Washbasin without overflow designed for wall or countertop tap fittings.
Countertop or built-in installation. Available in Color Elements finishings /
Waschtisch ohne Überlauf, geeignet für Wand- oder Standarmaturen.
Für Aufsatz- oder Einbaumontage. Erhältlich in den Color Elements-Ausführungen

Opzione colore / Color options / Faberoption

- | | |
|-------------------------------------|--------------------------------|
| <input type="radio"/> Bianco lucido | <input type="radio"/> Creta |
| <input type="radio"/> Bianco opaco | <input type="radio"/> Ghiaccio |
| <input type="radio"/> Agave | <input type="radio"/> Tortora |
| <input type="radio"/> Ardesia | |
| <input type="radio"/> Bistro | |
| <input type="radio"/> Cenere | |

Installazione / Installation / Installation

- Appoggio / Countertop / Aufsatzwaschbecken
- Incasso / Built-in / Einbaumontage

60×38
883711



50×38
884711



38×38
885011



Ø40
884611



Solo per /
Only for /
Nur für
Bianco lucido



extraglazeantibacterial®



60×38
Lavabo / Washbasin / Waschbecken



55x38
Lavabo / Washbasin / Waschbecken

Lavabo con foro troppopieno, predisposto per rubinetteria a parete o su piano.
 Installazione sottopiano /
 Washbasin with overflow, designed for wall or countertop tap fittings.
 Under counter installation /
 Waschtisch mit Überlauf, geeignet für Wand- oder Standarmaturen.
 Unterbaubefestigung

Opzione colore / Color options / Faberoption

Bianco lucido

Installazione / Installation / Installation

Sottopiano / Undercounter / Underbau

55x38
724311



50x35
724711



extraglazeantibacterial®



50x35
Lavabo / Washbasin / Waschbecken



50x36/F Agave
Wc e bidet / Wc and bidet / Wc und Bidet

Wc sospeso con sistema di scarico Swirflush®. Bidet sospeso con foro troppopieno e monoforo per rubinetteria. Disponibili nelle finiture Color Elements /
Wall-hung Wc with Swirflush® flushing system. Wall-hung bidet with overflow and single taphole for tap fitting. Available in Color Elements finishings /
WC in Wandaufhängung mit Spülsystem Swirflush®. Bidet wandhängend mit Überlauf und Hahnlochbefestigung. Erhältlich in den Ausführungen Color Elements

Opzione colore / Color options / Faberoption

- Bianco lucido
- Bianco opaco
- Agave
- Ardesia
- Bistro
- Cenere
- Creta
- Ghiaccio
- Tortora

55x36/F
881511



55x36
8865111



50x36/F
881611



50x36
8864111



Solo per /
Only for /
Nur für
Bianco lucido



extraglazeantibacterial®



swirflush®



quickrelease



softclose



dualglaze

Solo per /
Only for /
Nur für
Color elements



50x36/F
Wc e bidet / Wc and bidet / Wc und Bidet

Wc sospeso con sistema di scarico Rimless.
 Bidet sospeso con foro troppopieno e monoforo per rubinetteria /
 Wall-hung Wc with Rimless flushing system.
 Wall-hung bidet with overflow and single taphole for tap fittings /
 WC in Wandaufhängung mit Spülsystem Rimless.
 Bidet wandhängend mit Überlauf und Hahnlochbefestigung

Opzione colore / Color options / Faberoption

Bianco lucido

55x36/R
882111



55x36
8865111



extraglazeantibacterial®



quickrelease



softclose



55x36/R
 Wc e bidet / Wc and bidet / Wc und Bidet

266 Wc sospeso "eco" con sistema di scarico Swirflush®. Bidet sospeso "eco" con foro troppopieno e monoforo per rubinetteria. Fissaggio a vista / Wall hung wc "eco" with Swirflush® flushing system. Wall hung bidet "eco" with overflow and single taphole for tap fittings. Visible fixtures / „Eco“-WC in Wandaufhängung mit Spülsystem Swirflush®, „Eco“-Bidet in Wandaufhängung mit Überlauf und Hahnlochbefestigung. Sichtbare Befestigung

Opzione colore / Color options / Faberoption

Bianco lucido

55x35/F
881111



55x35
8861111



55x35/F
Wc e bidet / Wc and bidet / Wc und Bidet

Wc da terra con sistema di scarico Swirlflush®. Bidet da terra con foro troppopieno e monoforo per rubinetteria.
 Disponibili nelle finiture Color Elements 55x36/F 881011, 55x36 8862111 /
 Floor standing wc with Swirlflush® flushing system. Floor standing bidet with over flow and single taphole for tap fittings.
 Available in Color Elements finishings 55x36/F 881011, 55x36 8862111 /
 WC in Bodenmontage mit Spülsystem Swirlflush®. Bidet in Bodenmontage mit Überlauf und Hahnlochbefestigung. Erhältlich in den Ausführungen Color Elements 55x36/F 881011, 55x36 8862111

Opzione colore / Color options / Faberoption

- Bianco lucido
- Bianco opaco
- Agave
- Ardesia
- Bistro
- Cenere
- Creta
- Ghiaccio
- Tortora

55x36/F
881011



55x36
8862111



50x36/F
882011



50x36
8869111



Solo per /
Only for /
Nur für
Bianco lucido



extraglazeantibacterial[®]



swirlflush[®]



quickrelease



softclose



dualglaze

Solo per /
Only for /
Nur für
Color elements



55x36/F
Wc e bidet / Wc and bidet / Wc und Bidet

270 Wc da terra con sistema di scarico Rimless . Bidet da terra con foro troppopieno e monoforo per rubinetteria / Floor standing Wc with Rimless flushing system. Floor standing bidet with overflow and single taphole for tap fittings / WC in Bodenmontage mit Spülsystem Rimless. Bidet Bodenmontage mit Überlauf und Hahnlochbefestigung

Opzione colore / Color options / Faberoption

Bianco lucido

55x36/R
880911



55x36
8862111



extraglazeantibacterial®



quickrelease



softclose

55x36/R
Wc e bidet / Wc and bidet / Wc und Bidet

272 Wc monoblocco con scarico a parete trasformabile a pavimento tramite curva tecnica. Disponibile nella versione con scocca in ceramica o con cassetta / Close-coupled wc with wall outlet modifiable to floor outlet using S-curve plumbing. Available in one body ceramic shell or with cistern / Monoblock-WC mit horizontalem Ablauf mittels Anschlussbogens auch zu Bodenablauf umfunktionierbar. Erhältlich in der Version mit Keramikabdeckung oder Spülkasten

Opzione colore/Color options/Faberoption

Bianco lucido

68x38^a
881711



68x38^b
881711



extraglazeantibacterial®



quickrelease



softclose



68x38
Wc

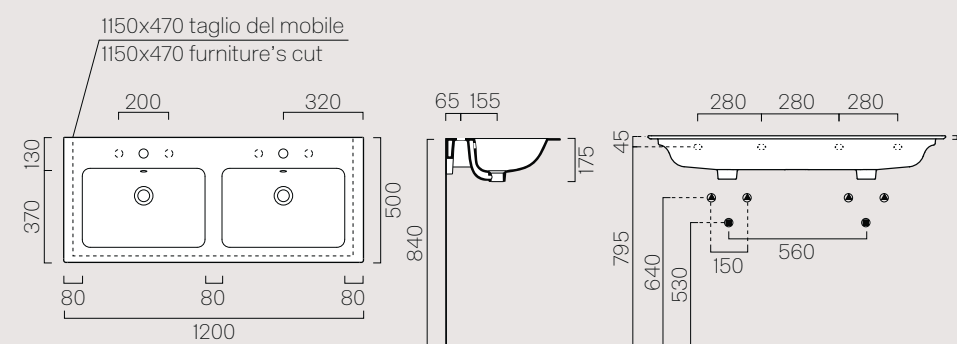

120x50
8845111

Description	Washbasin
Code	8845111
Dimensions	120x50
Weight	Kg 28
Capacity	Lt 12
Overflow	CL 25
Installation	Wall-hung, Built-in
Taphole	1 (3)

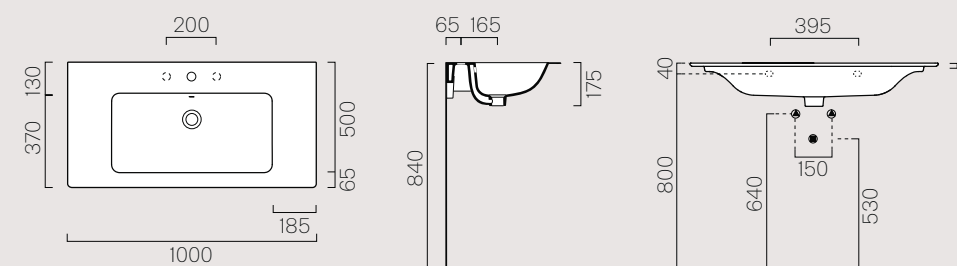

100x50
8844111

Description	Washbasin
Code	8844111
Dimensions	100x50
Weight	Kg 21
Capacity	Lt 10
Overflow	CL 25
Installation	Wall-hung, Built-in
Taphole	1 (3)

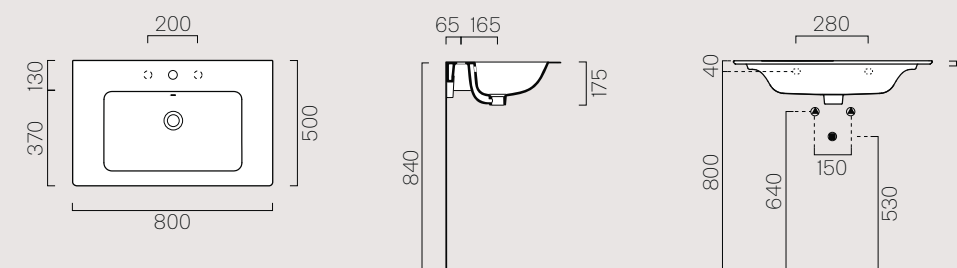

80x50
8843111

Description	Washbasin
Code	8843111
Dimensions	80x50
Weight	Kg 16,8
Capacity	Lt 8
Overflow	CL 25
Installation	Wall-hung, Built-in
Taphole	1 (3)

60x50
8836111

Description	Washbasin
Code	8836111
Dimensions	60x50
Weight	Kg 13,4
Capacity	Lt 6
Overflow	CL 25
Installation	Wall-hung, Built-in
Taphole	1(3)

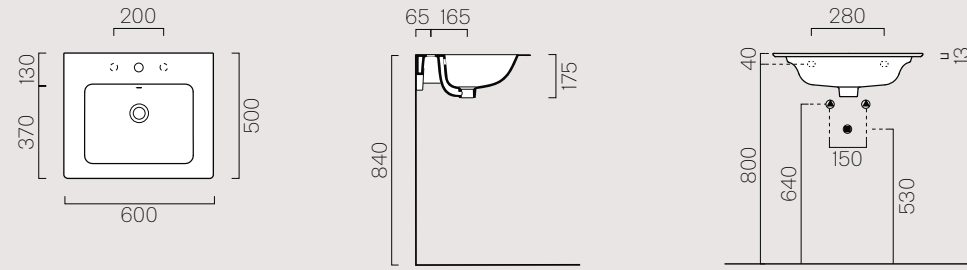

62x46
8839111

Description	Washbasin
Code	8839111
Dimensions	62x46
Weight	Kg 12,4
Capacity	Lt 6
Overflow	CL 25
Installation	Wall-hung, Built-in
Taphole	1(3)

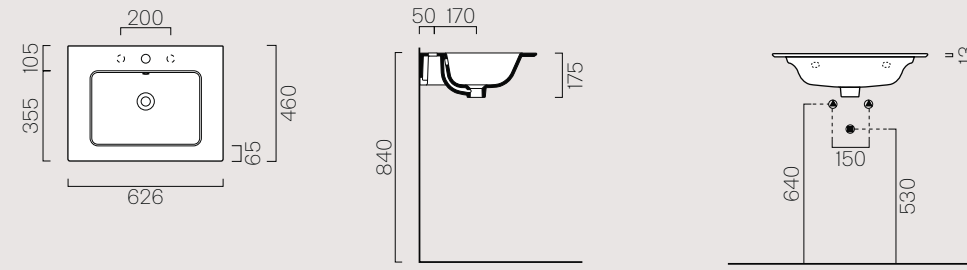

122x46
8840111

Description	Washbasin
Code	8840111
Dimensions	122x46
Weight	Kg 25
Capacity	Lt 15
Overflow	CL 25
Installation	Wall-hung, Built-in
Taphole	1(5)

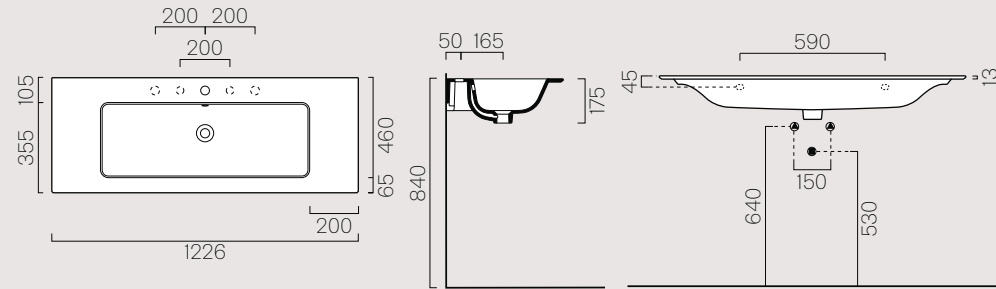

102x52
8825111

Description	Washbasin
Code	8825111
Dimensions	102x52 h19
Weight	Kg 21,2
Capacity	Lt 9,5
Overflow	CL 25
Installation	Wall-hung, Built-in
Taphole	1(3)

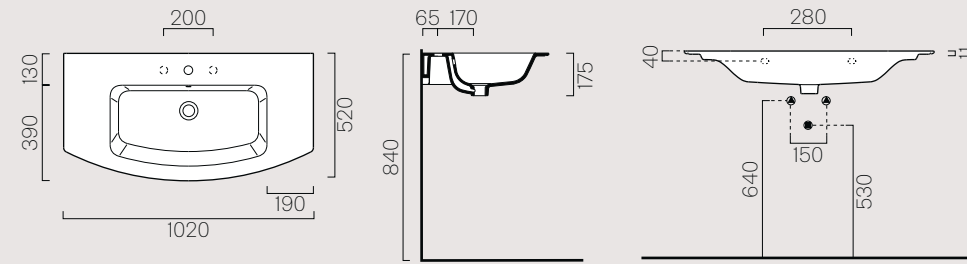

102x46
8833111

Description	Washbasin
Code	8833111
Dimensions	102x46
Weight	Kg 19,8
Capacity	Lt 9
Overflow	CL 25
Installation	Wall-hung, Built-in
Taphole	1(3)

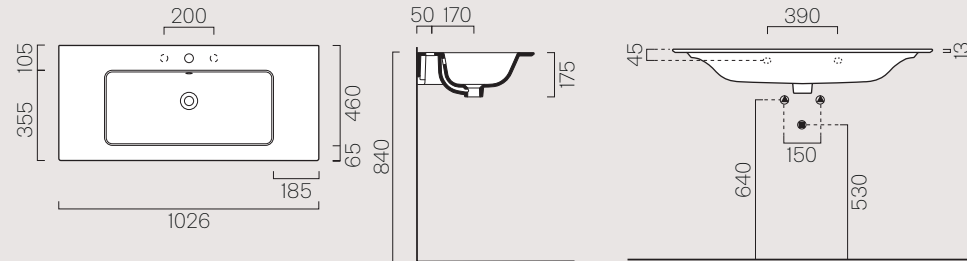

82x49
8826111

Description	Washbasin
Code	8826111
Dimensions	82x49 h19
Weight	Kg 15,3
Capacity	Lt 9
Overflow	CL 25
Installation	Wall-hung, Built-in
Taphole	1(3)

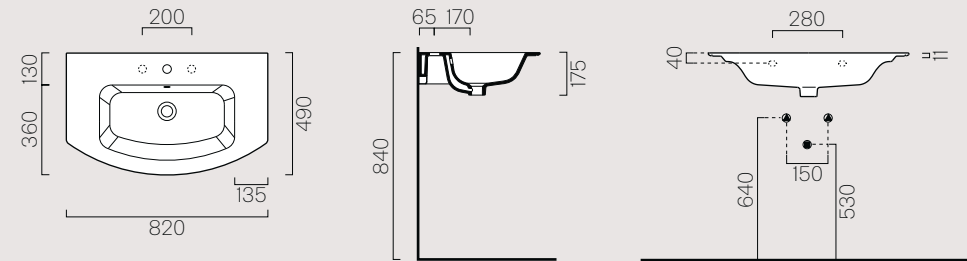

82x46
8838111

Description	Washbasin
Code	8838111
Dimensions	82x46
Weight	Kg 16
Capacity	Lt 8
Overflow	CL 25
Installation	Wall-hung, Built-in
Taphole	1(3)

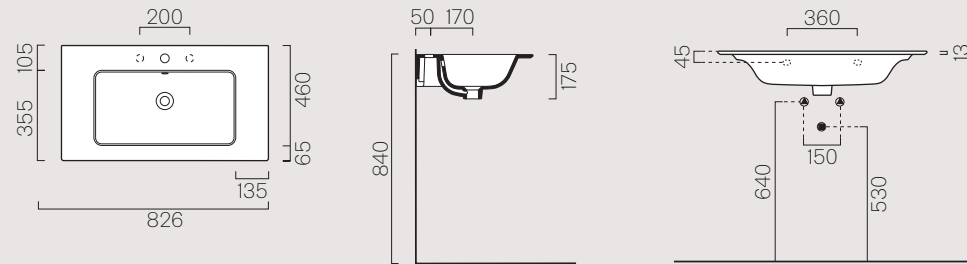

62x48
8827111

Description	Washbasin
Code	8827111
Dimensions	62x48 h19
Weight	Kg 11,1
Capacity	Lt 6
Overflow	CL 25
Installation	Wall-hung, Built-in
Taphole	1(3)

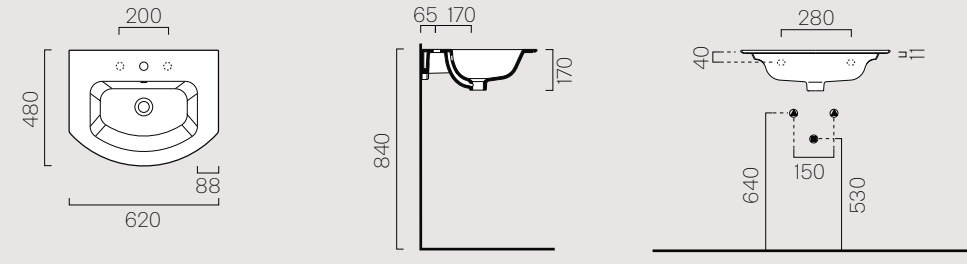

52x44 883011

Description	Washbasin
Code	883011
Dimensions	52x44 h19
Weight	Kg 9,2
Capacity	Lt 4
Overflow	CL 25
Installation	Wall-hung, Built-in
Taphole	1

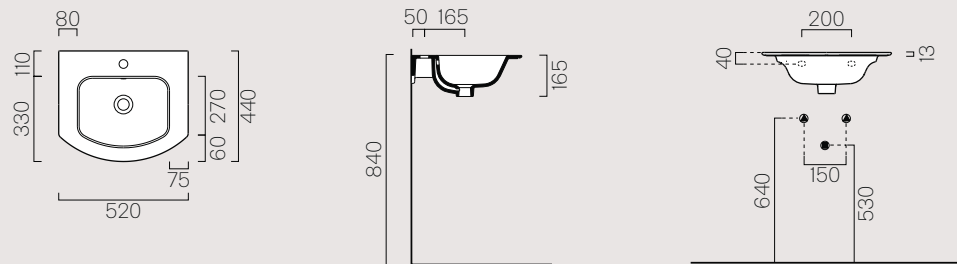

Ø42 885111

Description	Washbasin
Code	885111
Dimensions	Ø42
Weight	Kg 7,8
Capacity	Lt 7
Overflow	CL 00
Installation	Countertop
Taphole	0



60x42 884211

Description	Washbasin
Code	884211
Dimensions	60x42 h16
Weight	Kg 9,9
Capacity	Lt 10
Overflow	CL 00
Installation	Countertop
Taphole	0

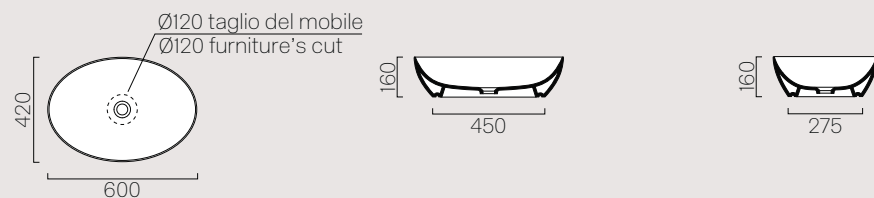

Ø42 885511

Description	Washbasin
Code	885511
Dimensions	Ø42
Weight	Kg 7,8
Capacity	Lt 7
Overflow	CL 00
Installation	Countertop
Taphole	0



60x37 883411

Description	Washbasin
Code	883411
Dimensions	60x37 h16
Weight	Kg 11
Capacity	Lt 9
Overflow	CL 00
Installation	Countertop
Taphole	0

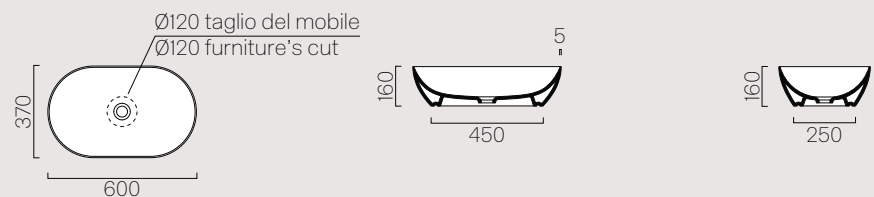

Ø42 h22 885211

Description	Washbasin
Code	885211
Dimensions	Ø42
Weight	Kg 10
Capacity	Lt 11
Overflow	CL 00
Installation	Countertop
Taphole	0



50x35 886011

Description	Washbasin
Code	886011
Dimensions	50x35 h16
Weight	Kg 7,9
Capacity	Lt 5
Overflow	CL 00
Installation	Countertop
Taphole	0

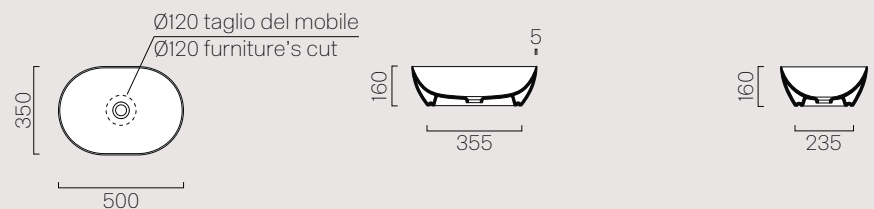

Ø32 885411

Description	Washbasin
Code	885411
Dimensions	Ø32
Overflow	CL 00
Installation	Countertop
Taphole	0



60×38 883711

Description	Washbasin
Code	883711
Dimensions	60×38 h14
Weight	Kg 12,8
Capacity	Lt 9
Overflow	CL 00
Installation	Built-in, Countertop
Taphole	0

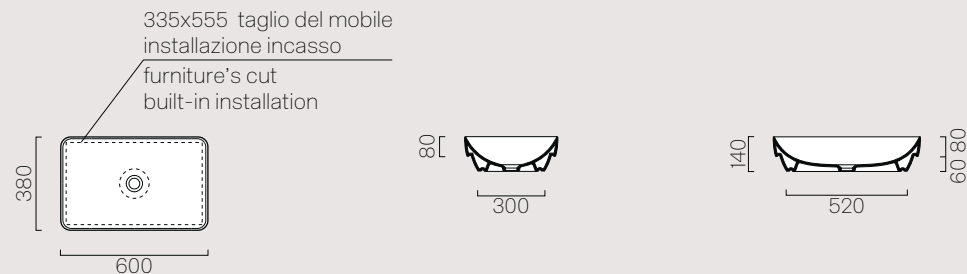

55×38 724311

Description	Washbasin
Code	724311
Dimensions	55×38
Weight	Kg 8
Capacity	Lt 9,5
Overflow	CL 25
Installation	Under-counter
Taphole	0

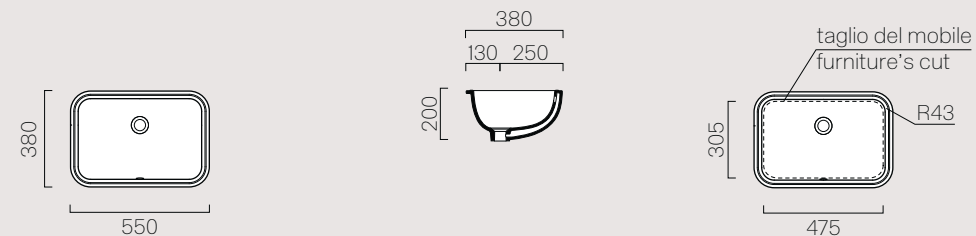

50×38 884711

Description	Washbasin
Code	884711
Dimensions	50×38 h14
Weight	Kg 10,1
Capacity	Lt 7
Overflow	CL 00
Installation	Built-in, Countertop
Taphole	0

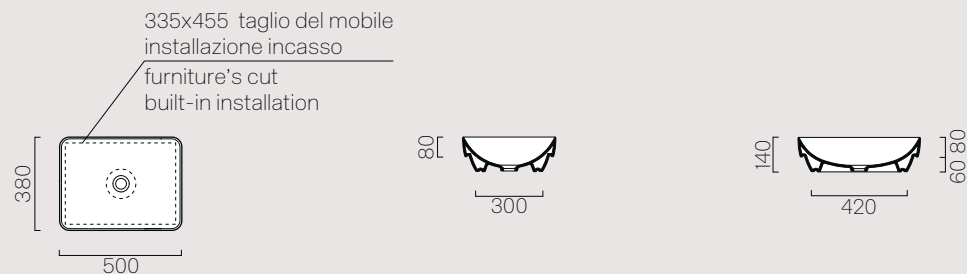

50×35 724711

Description	Washbasin
Code	724711
Dimensions	50×35
Weight	Kg 7,6
Capacity	Lt 8
Overflow	CL 25
Installation	Under-counter
Taphole	0

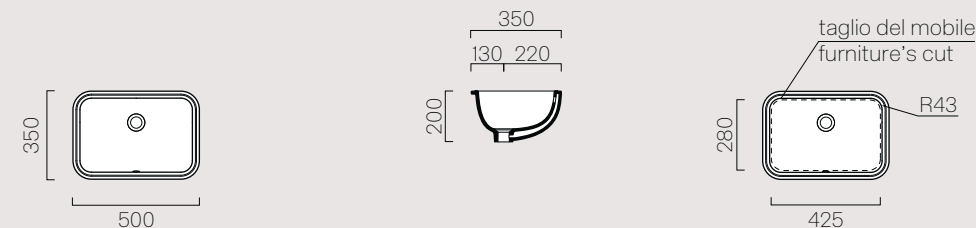

38×38 885011

Description	Washbasin
Code	885011
Dimensions	38×38 h14
Weight	Kg 8,7
Capacity	Lt 5
Overflow	CL 00
Installation	Built-in, Countertop
Taphole	0



Wc e Bidet/Wc and Bidet/Wc und bidet

Ø40 884611

Description	Washbasin
Code	884611
Dimensions	Ø40 h14
Weight	Kg 7,5
Capacity	Lt 5
Overflow	CL 00
Installation	Built-in, Countertop
Taphole	0



55×36/F 881511

Description	Wc
Code	881511
Dimensions	55×36
Weight	Kg 18,5
Flush system	Swirflush®
Installation	Wall-hung

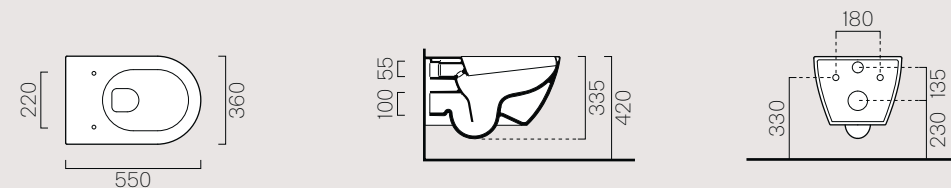

Non è consigliato l'impiego di cassette di scarico esterne o impianti dotati di rubinetto flussometro /
We do not recommend the use of external flushing cisterns or systems endowed with flushometer valves /
Empfohlen wird die Verwendung eines externen Spülkastens oder einer Selbstschlussarmatur

55x36/R
882111

Description	Wc
Code	882111
Dimensions	55x36
Weight	Kg 20
Flush system	Rimless
Installation	Wall-hung

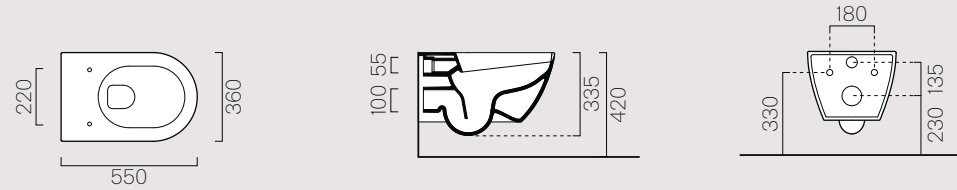

54,5x35/F
881111

Description	Wc
Code	881111
Dimensions	54,5x35
Weight	Kg 23,3
Flush system	Swiriflush®
Installation	Wall-hung

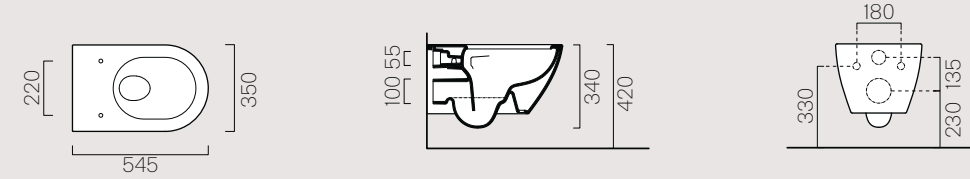

Non è consigliato l'impiego di cassette di scarico esterne o impianti dotati di rubinetto flussometro /
We do not recommend the use of external flushing cisterns or systems endowed with flushometer valves /
Empfohlen wird die Verwendung eines externen Spülkastens oder einer Selbstschlussarmatur

55x36
8865111

Description	Bidet
Code	8865111
Dimensions	55x36
Weight	Kg 17
Overflow	CL 25
Installation	Wall-hung
Taphole	1

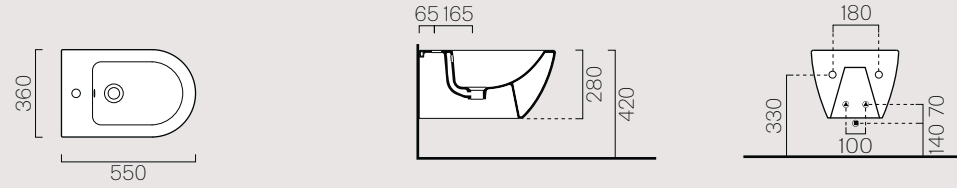

54,5x35
8861111

Description	Bidet
Code	8861111
Dimensions	54,5x35
Weight	Kg 17,1
Overflow	CL 25
Installation	Wall-hung
Taphole	1

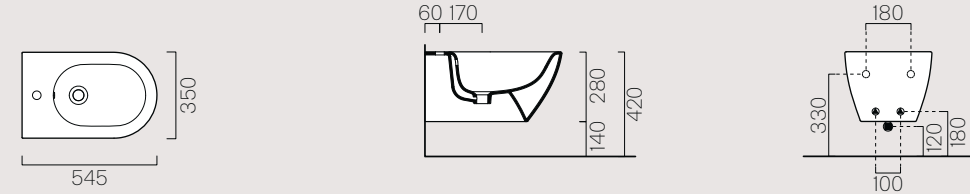

50x36/F
881611

Description	Wc
Code	881611
Dimensions	50x36
Weight	Kg 22,8
Flush system	Swiriflush®
Installation	Wall-hung

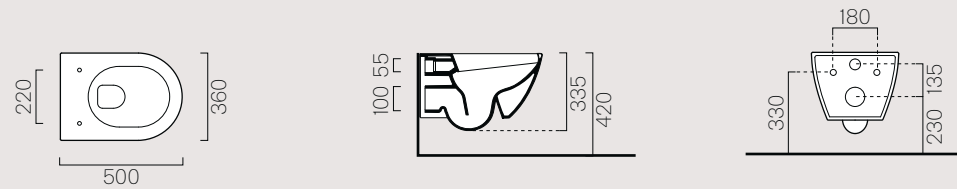

55x36/F
881011

Description	Wc
Code	881011
Dimensions	55x36
Weight	Kg 23,5
Flush system	Swiriflush®
Installation	Floor standing

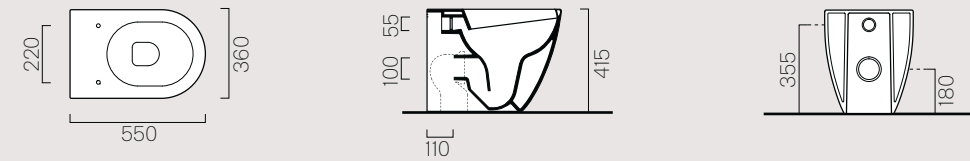

Curva tecnica /
Technical curve

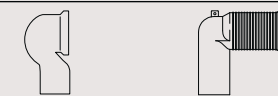

Codice /
Codes

MCURVA MCURVA90

Interasse /
Distance

*110 *70

Non è consigliato l'impiego di cassette di scarico esterne o impianti dotati di rubinetto flussometro /
We do not recommend the use of external flushing cisterns or systems endowed with flushometer valves /
Empfohlen wird die Verwendung eines externen Spülkastens oder einer Selbstschlussarmatur

50x36
8864111

Description	Bidet
Code	8864111
Dimensions	50x36
Weight	Kg 16,3
Overflow	CL 25
Installation	Wall-hung
Taphole	1

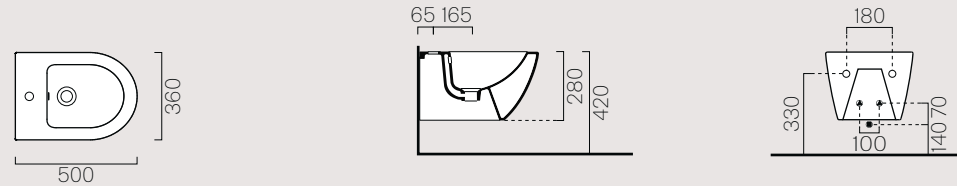

55x36/R
880911

Description	Wc
Code	880911
Dimensions	55x36
Weight	Kg 28,5
Flush system	Rimless
Installation	Floor standing

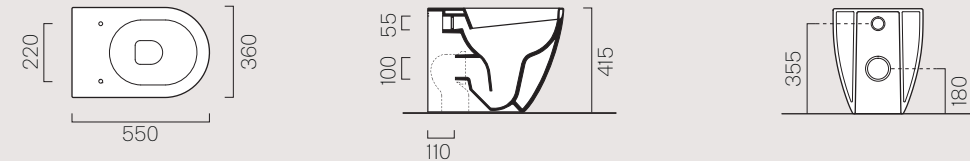

55x36
886211

Description	Bidet
Code	886211
Dimensions	55x36
Weight	Kg 23,1
Overflow	CL 25
Installation	Floor standing
Taphole	1

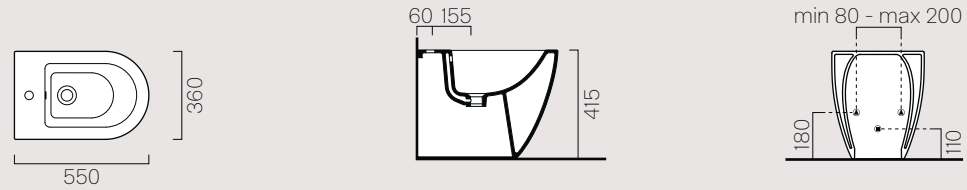

50x36/F
882011

Description	Wc
Code	882011
Dimensions	50x36
Weight	Kg 25
Flush system	Swirflush®
Installation	Floor standing

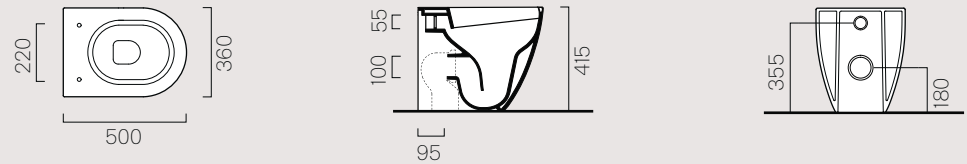

Curva tecnica / Technical curve		
Codice / Codes	MCURVA	MCURVA90
Interasse / Distance	*95	*65

Non è consigliato l'impiego di cassette di scarico esterne o impianti dotati di rubinetto flussometro / We do not recommend the use of external flushing cisterns or systems endowed with flushometer valves / Empfohlen wird die Verwendung eines externen Spülkastens oder einer Selbstschlussarmatur

50x36
8869111

Description	Bidet
Code	8869111
Dimensions	50x36
Weight	Kg 18
Overflow	CL 25
Installation	Floor standing
Taphole	1

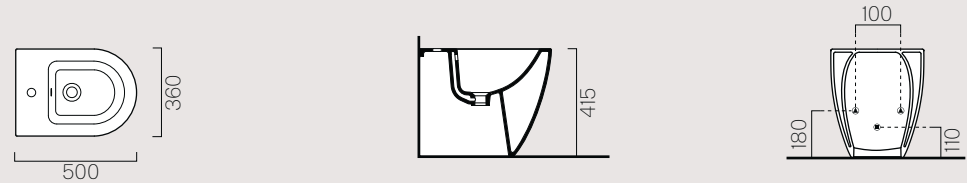

68x36
881711

Description	Wc
Code	881711
Dimensions	68x36
Weight	Kg 33,3
Flush system	Standard
Installation	Floor standing

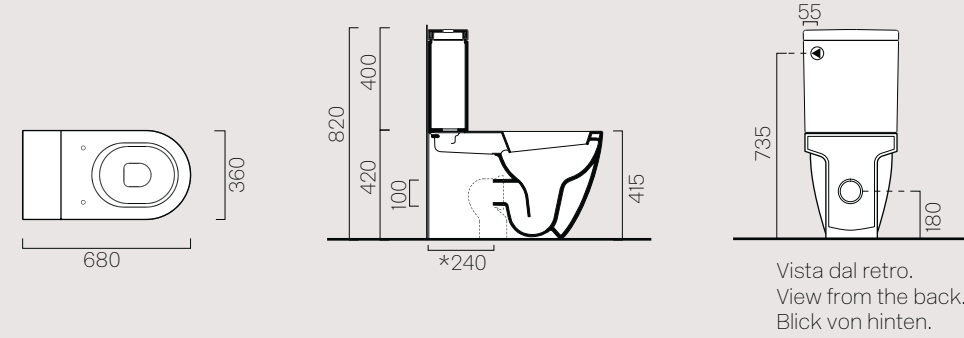

Vista dal retro.
View from the back.
Blick von hinten.

Curva tecnica / Technical curve		
Codice / Codes	MCURVAS	MCURVA90
Interasse / Distance	*Da 230 a 305 mm *From 230 to 305 mm	*Da 80 a 205 mm *From 80 to 205 mm

Cassetta/Cistern
868111

Description	Cistern
Code	868111
Dimensions	17x31,43h
Weight	Kg 13,5

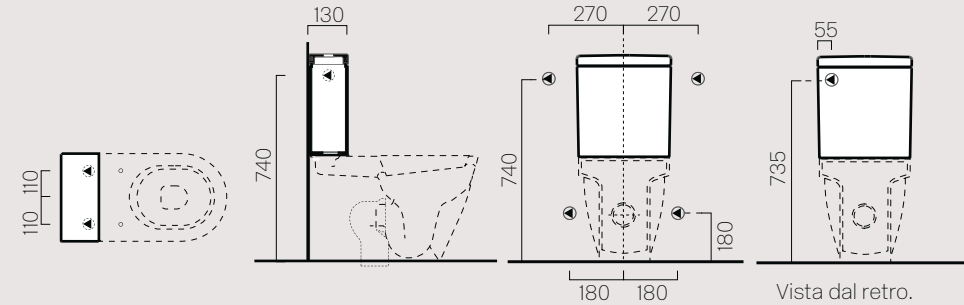

Vista dal retro.
View from the back.
Blick von hinten.

Scocca/Ceramic Cover
869111

Description	Ceramic Cover
Code	869111
Dimensions	13x35,5 46h
Weight	Kg 9,6

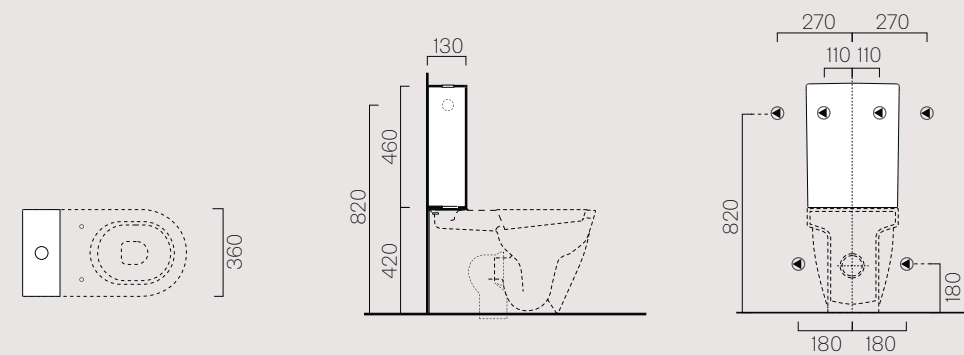

Vista dal retro.
View from the back.
Blick von hinten.



IT Modo è la collezione premium economy composta da due coppie di sanitari, sospesa e da terra, caratterizzata da linee sinuose ed avvolgenti. Prodotti neutri, ma di grande impatto, che trovano immediata collocazione in differenti ambienti grazie ad una trasversalità che permette innumerevoli abbinamenti con lavabi di forme e installazione differenti. Modo è destinata ad un target che ha la necessità di ponderare la scelta d'acquisto sia in termini quantitativi che qualitativi. I sanitari prevedono tutti i Plus GSI disponibili: la smaltatura Extraglaze® Antibacterial, il sistema di scarico Swirlflush®, i copriwater ad estrazione rapida e senza utensili del sistema Quick Release abbinati al sistema di chiusura rallentata Soft Close.

EN Modo is the premium economy collection consisting of two pairs of sanitaryware items, wall-mounted and freestanding, characterized by their curvy forms. Products that are neutral yet make a great impact, and can find a home in different settings, allowing countless combinations with washbasins of different shapes and installation types. Modo is aimed at a customer target that needs to weigh up purchase choices in both quantitative and qualitative terms. The sanitaryware in this collection has all the benefits of GSI products: Antibacterial Extraglaze®, Swirlflush® system, Quick Release tool-free removal system and Soft Close system for toilet seats.

DE Modo ist die Premium Economy Kollektion, die sich aus zwei Paaren von - hängend oder am Boden stehend montierten - Sanitäröbekten zusammensetzt, welche durch ihre geschwungenen und umhüllenden Linien gekennzeichnet sind. Neutrale Produkte mit großer optischer Wirkung, die sich dank ihrer Universalität unmittelbar in unterschiedliche Umgebungen einfügen, da sie zahllose Kombinationen mit Waschbecken unterschiedlicher Formen und Montagearten gestatten. Modo ist für ein Target bestimmt, das seine Kaufentscheidung sowohl auf quantitative als auch auf qualitative Elemente stützt. Die Sanitäröbekte sind mit allen bei GSI verfügbaren Plus-Funktionen erhältlich: Glasur Extraglaze® Antibacterial, Spülsystem Swirlflush®, Toilettendeckel mit schneller und werkzeugloser Demontage dank dem System Quick Release und gebremste Absenkautomatik Soft Close.

Norm 60x49

Lavabo / Washbasin / Waschbecken

52x37/F

Wc e bidet / Wc and bidet / Wc und Bidet

Modo

60x42
884211
p.252



60x37
883411
p.254



Ø42
885111
p.256



80x50
8644111
p.220



60x49
8645111
p.220



51x45
8646111
p.220



52x37/F
981611
9864111
p.292



52x37/F
981011
9862111
p.294





Pura 60x42
Lavabo / Washbasin / Waschbecken



52x37/F
Wc e bidet / Wc and bidet / Wc und Bidet

292 Wc sospeso con sistema di scarico Swirflush®. Bidet sospeso con foro troppopieno e monoforo per rubinetteria / Wall-hung wc with Swirflush® flushing system. Wall-hung bidet with overflow and one taphole for tap fittings / WC wandhängend mit Spülsystem Swirflush® Bidet wandhängend mit Überlauf und Hahnlochbefestigung

Opzione colore / Color options / Faberoption

Bianco lucido

52x37/F
981611



52x37
9864111



extraglazeantibacterial®



swirlflush®



quickrelease



softclose



52x37/F
Wc e bidet / Wc and bidet / Wc und Bidet

Wc in appoggio con sistema di scarico Swirlflush®, predisposto per scarico a parete o a pavimento tramite curva tecnica. Bidet in appoggio con foro troppopieno e monoforo per rubinetteria /
 Floor standing wc with Swirlflush® flushing system, designed for wall or floor outlet using S-curve plumbing. Floor standing bidet with overflow and one taphole for tap fittings /
 WC zur aufgesetzten Installation mit Spülsystem Swirlflush®, geeignet für Wand-oder Bodeninstallation mithilfe eines Anschlussbogens.
 Bidet zur aufgesetzten Installation mit Überlauf und Hahnlochbefestigung

Opzione colore/Color options/Faberoption

Bianco lucido

52x37/F
 981011



52x37
 9862111



extraglazeantibacterial®



swirlflush®



quickrelease



softclose



52x37/F
 Wc e bidet / Wc and bidet / Wc und Bidet

60×42
884211

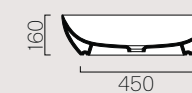
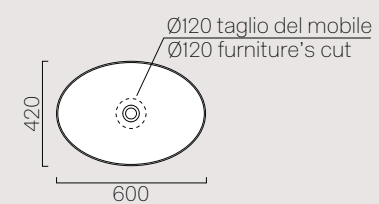

Description	Washbasin
Code	884211
Dimensions	60×42 h16
Weight	Kg 9,9
Capacity	Lt 10
Overflow	CL 00
Installation	Countertop
Taphole	0

60×37
883411

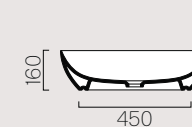
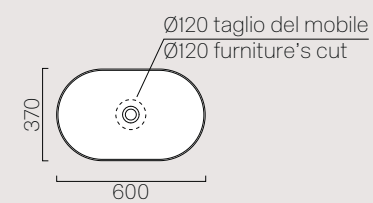

Description	Washbasin
Code	883411
Dimensions	60×37 h16
Weight	Kg 11
Capacity	Lt 9
Overflow	CL 00
Installation	Countertop
Taphole	0

Ø42
885111

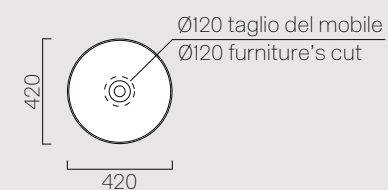

Description	Washbasin
Code	885111
Dimensions	Ø42
Weight	Kg 7,8
Capacity	Lt 7
Overflow	CL 00
Installation	Countertop
Taphole	0

80×50 864411

Description	Washbasin
Code	864411
Dimensions	80×50 h18
Weight	Kg 17,8
Capacity	Lt 8
Overflow	CL 25
Installation	Wall-hung, Built-in
Taphole	1(3)

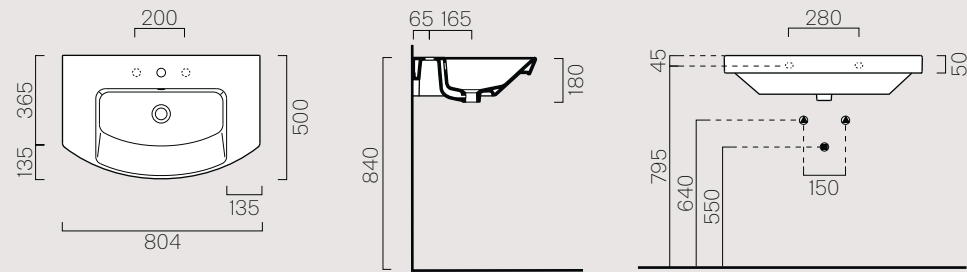

60×49 864511

Description	Washbasin
Code	864511
Dimensions	60×49 h18
Weight	Kg 14,2
Capacity	Lt 6
Overflow	CL 25
Installation	Wall-hung, Built-in
Taphole	1(3)

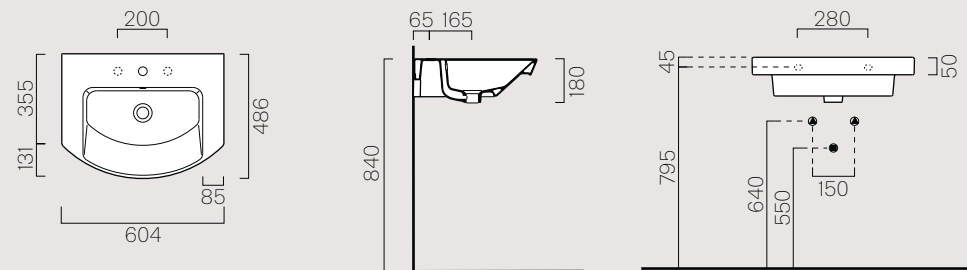

51×45 864611

Description	Washbasin
Code	864611
Dimensions	51×45 h18
Weight	Kg 11,4
Capacity	Lt 4,5
Overflow	CL 25
Installation	Wall-hung, Built-in
Taphole	1

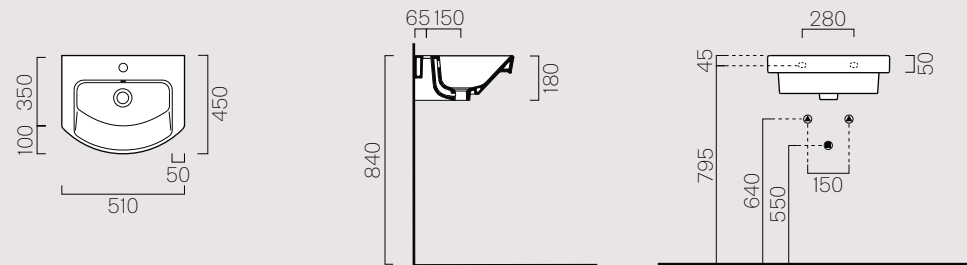

Wc e Bidet/Wc and Bidet/Wc und bidet

52×37/F 981611

Description	Wc
Code	981611
Dimensions	52×37
Flush system	Swirflush®
Installation	Wall-hung

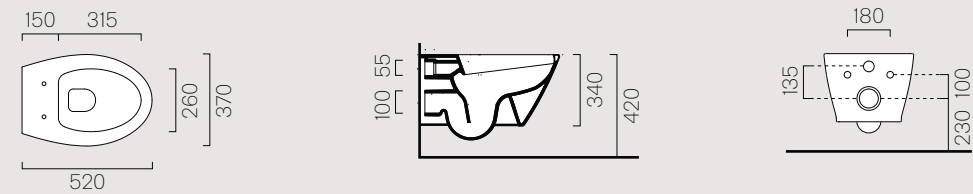

Non è consigliato l'impiego di cassette di scarico esterne o impianti dotati di rubinetto flussometro /
We do not recommend the use of external flushing cisterns or systems endowed with flushometer valves /
Empfohlen wird die Verwendung eines externen Spülkastens oder einer Selbstschlussarmatur

52×37 986411

Description	Bidet
Code	986411
Dimensions	52×37
Installation	Wall-hung
Taphole	1

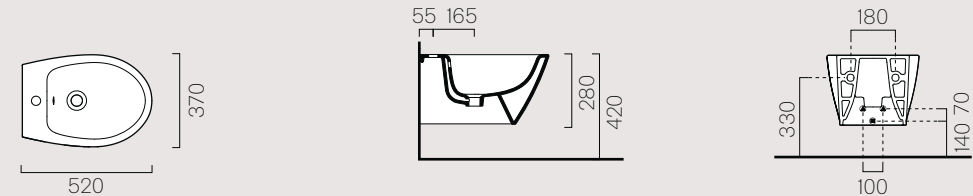

52×37/F 981011

Description	Wc
Code	981011
Dimensions	52×37
Flush system	Swirflush®
Installation	Floor standing

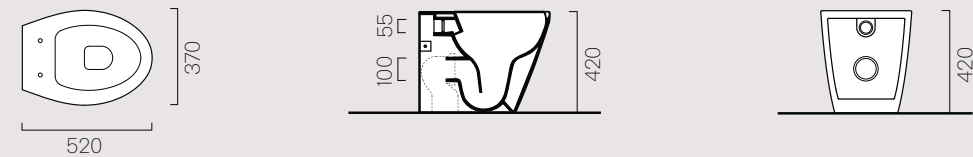

Non è consigliato l'impiego di cassette di scarico esterne o impianti dotati di rubinetto flussometro /
We do not recommend the use of external flushing cisterns or systems endowed with flushometer valves /
Empfohlen wird die Verwendung eines externen Spülkastens oder einer Selbstschlussarmatur

52×37 986211

Description	Bidet
Code	986211
Dimensions	52×37
Installation	Floor standing
Taphole	1

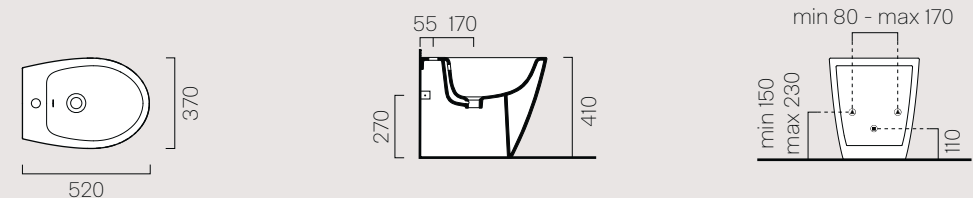



IT Il linguaggio di ispirazione neoclassica guida la famiglia di lavabi e sanitari della storica collezione Classic. I lavabi sono installabili a sospensione, sottopiano o su colonna ceramica, abbinabili a sanitari a terra, a sospensione o monoblocco.

EN Neoclassical themes are the inspiration behind the GSI's historical collection of washbasins and sanitary ware. Washbasins can be mounted on the wall, undercounter or on a ceramic pedestal and are combinable with floor standing, suspended or close-coupled sanitary ware.

DE Einer neoklassizistischen Formensprache ist diese Familie von Waschtischen und Sanitär Möbeln der historischen Kollektion Classic verpflichtet. Die Waschtische lassen sich wandhängend, als Unterbau oder auf Keramiksäule einbauen und sind mit WC und Bidets in Boden-, Wand- oder Monoblock-Installation kombinierbar.

75x50
Lavabo / Washbasin / Waschbecken

Classic

125x54
8725111
p.310



55x38
724311
p.314



105x54
8723111
p.310



50x35
724711
p.314



90x50
8788111
p.312



75x50
8787111
p.312



60x46
8731111
p.312



55x37
871211
8765111
p.316



54x37
871011
871111
8762111
p.318



70x37
871711
p.320





125x54
Lavabo / Washbasin / Waschbecken

55x37
Wc e bidet / Wc and bidet / Wc und Bidet



75x50
Lavabo / Washbasin / Waschbecken

54x37
Wc e bidet / Wc and bidet / Wc und Bidet



105x54
Lavabo / Washbasin / Waschbecken



54x37
Wc e bidet / Wc and bidet / Wc und Bidet

90x50
Lavabo / Washbasin / Waschbecken

Lavabo con foro troppopieno e monoforo per rubinetteria predisposto per tre fori. Installazione a sospensione o su gambe in ceramica. Solo nella versione 105x54 8723111 su colonna in ceramica / Washbasin with overflow and single taphole for tap fittings designed for three holes. Wall-hung installation or on ceramic legs. Only in model 104x54 8723111 on ceramic pedestal / Waschtisch mit Überlauf und Hahnlochbefestigung, geeignet für Armaturen mit drei Löchern. Wandhängend oder auf Standbeinen aus Keramik. Nur in der Version 105x54 8723111 auf Keramiksäule

Opzione colore/Color options/Faberoption

Bianco lucido

Installazione/Installation/Installation

Sospensione/Wall-hung/Wandhängend

Gambe/Legs/Standbeinen

Colonna/On pedestal/Säulenwaschbecke

125x54
8725111



105x54
8723111



extraglazeantibacterial®



105x54
Lavabo / Washbasin / Waschbecken

312 Lavabo con foro troppopieno e monoforo per rubinetteria, predisposto per tre fori. Installazione a sospensione o su colonna in ceramica / Washbasin with overflow and single taphole for tap fittings designed for three holes. Wall-hung installation or on ceramic pedestal / Waschtisch mit Überlauf und Hahnlochbefestigung für drei Löcher. Wandhängend oder auf Standbeinen aus Keramik

Opzione colore / Color options / Faberoption

Bianco lucido

Installazione / Installation / Installation

Sospensione / Wall-hung / Wanshängend

Colonna / On pedestal / Säulenwaschbecke

90×50
8788111



75×50
8787111



60×46
8731111



extraglazeantibacterial®



90×50
Lavabo / Washbasin / Waschbecken

314 Lavabo con foro troppopieno predisposto per rubinetteria a parete o su piano.
Installazione sottopiano /
Washbasin with overflow and single taphole for wall or countertop tap fittings.
Installation undercounte /
Waschtisch mit Überlauf, geeignet für Wand- oder Standarmaturen.
Unterbaubefestigung

Opzione colore / Color options / Faberoption

Bianco lucido

Installazione / Installation / Installation

Sottopiano / Undercounter / Underbau

55x38
724311



50x35
724711



extraglazeantibacterial®



55x38
Lavabo / Washbasin / Waschbecken

Opzione colore/Color options/Faberoption

Bianco lucido

55x37
871211



55x37
8765111



extraglazeantibacterial®



save water



quickrelease



softclose

55x37
Wc e bidet / Wc and bidet / Wc und Bidet



318 Wc a terra con scarico a pavimento o a parete. Bidet con foro troppopieno e monoforo per rubinetteria, predisposto per tre fori / Floor standing wc with floor or wall outlet. Bidet with overflow and single taphole for tap fittings, designed for three holes / WC in Bodenmontage mit horizontalem oder Bodenablauf. Bidet mit Überlauf und Hahnlochbefestigung, geeignet für Armaturen mit drei Löchern

Opzione colore / Color options / Faberoption

Bianco lucido

54x37
871011
871111



54x37
8762111



extraglazeantibacterial®



save water



quickrelease



softclose



125x54
Lavabo / Washbasin / Waschbecken

54x37
Wc e bidet / Wc and bidet / Wc und Bidet



70x37 / 54x37
Wc e bidet / Wc and bidet / Wc und Bidet

Wc monoblocco con scarico a parete trasformabile a pavimento tramite curva tecnica non a corredo /
Close-coupled wc with wall outlet modifiable to floor outlet using S-curve plumbing not included in set /
Monoblock-WC mit horizontalem Ablauf mittels (nicht mitgeliefertem Anschlussbogens) auch zu Bodenablauf umfunktionierbar

Opzione colore / Color options / Faberoption

- Bianco lucido

70x37
871711



  
extraglazeantibacterial® quickrelease softclose



70x37
Wc

54x37
Bidet

125x54
8725111

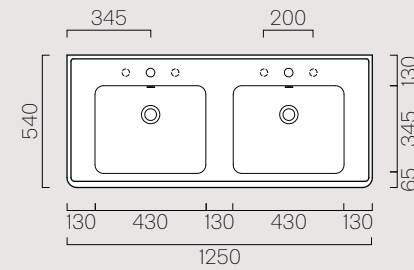

Description	Washbasin
Code	8725111
Dimensions	125x54
Weight	Kg 42,1
Capacity	Lt 10
Overflow	CL 25
Installation	Wall-hung, Ceramic legs
Taphole	1 (3)

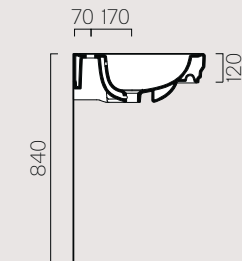
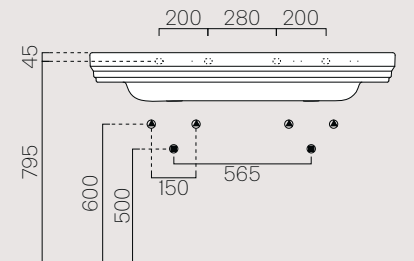

105x54
8723111

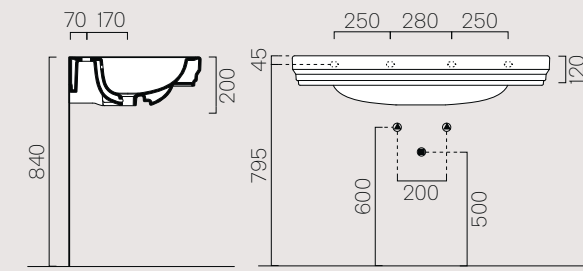
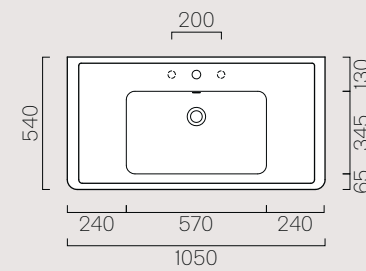

Description	Washbasin
Code	8723111
Dimensions	105x54
Weight	Kg 28
Capacity	Lt 12
Overflow	CL 25
Installation	Wall-hung, Ceramic legs, Pedestal
Taphole	1 (3)

90x50
8788111

Description	Washbasin
Code	8788111
Dimensions	90x50
Weight	Kg 25,3
Capacity	Lt 10,5
Overflow	CL 25
Installation	Wall-hung, Pedestal
Taphole	1(3)

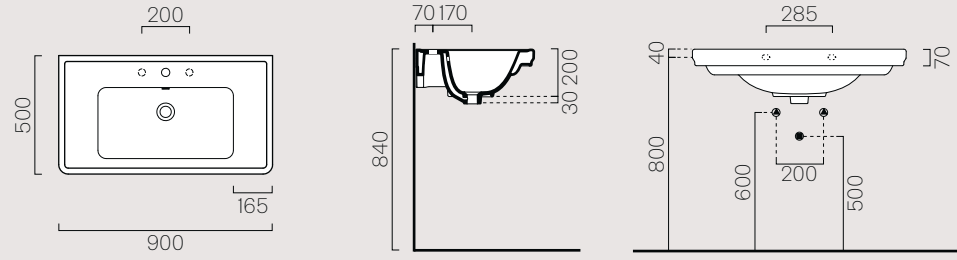

55x38
724311

Description	Washbasin
Code	724311
Dimensions	55x38
Weight	Kg 8
Capacity	Lt 9,5
Overflow	CL 25
Installation	Under-counter
Taphole	0

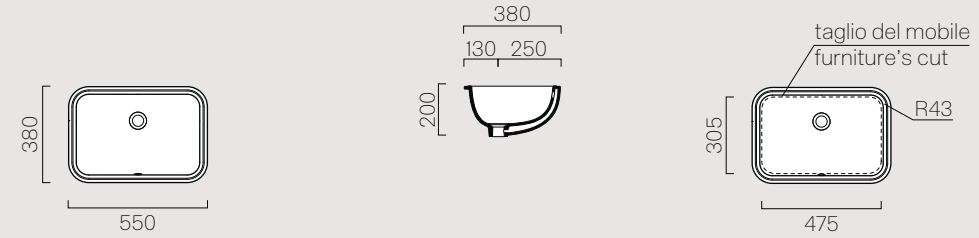

75x50
8787111

Description	Washbasin
Code	8787111
Dimensions	75x50
Weight	Kg 19,3
Capacity	Lt 6
Overflow	CL 25
Installation	Wall-hung, Pedestal
Taphole	1(3)

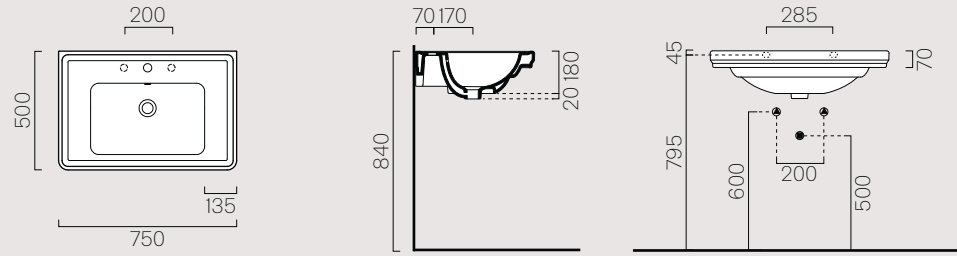

50x35
724711

Description	Washbasin
Code	724711
Dimensions	50x35
Weight	Kg 7,6
Capacity	Lt 8
Overflow	CL 25
Installation	Under-counter
Taphole	0

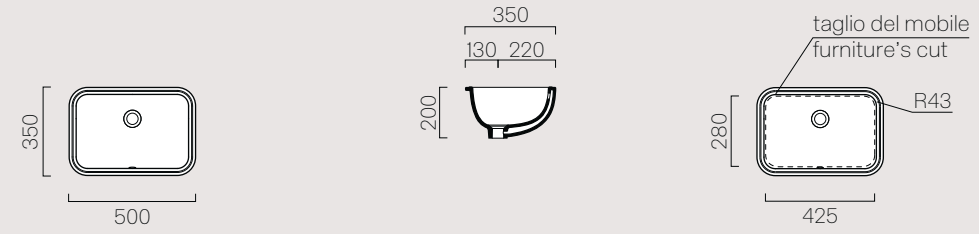

60x46
8731111

Description	Washbasin
Code	8731111
Dimensions	60x46
Weight	Kg 15,5
Capacity	Lt 5
Overflow	CL 25
Installation	Wall-hung, Pedestal
Taphole	1(3)

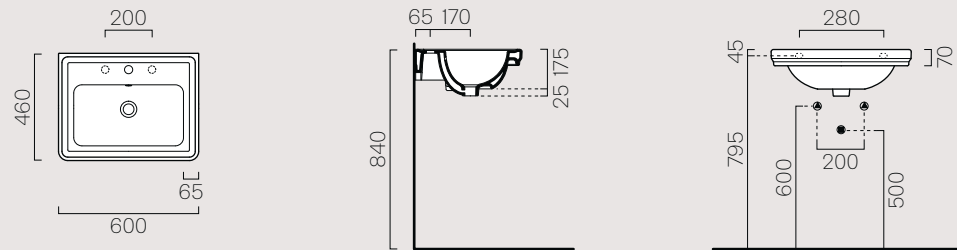

Colonna/Pedestal
877011

Description	Pedestal
Code	877011
Dimensions	66x27

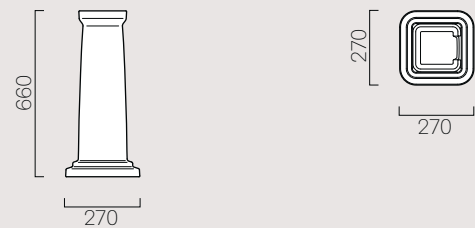

Wc e Bidet/Wc and Bidet/Wc und bidet

**55x37
871211**

Description	Wc
Code	871211
Dimensions	55x37
Weight	Kg 20,5
Flush system	Standard
Installation	Wall-hung

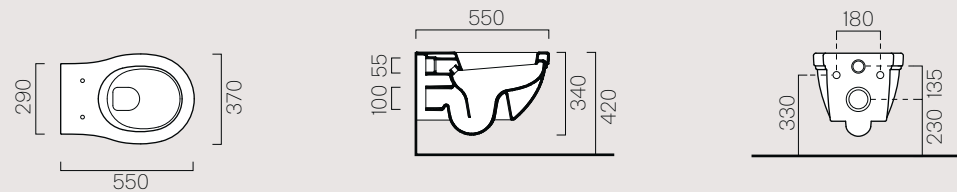

**55x37
8765111**

Description	Bidet
Code	8765111
Dimensions	55x37
Weight	Kg 17
Overflow	CL 25
Installation	Wall-hung
Taphole	1

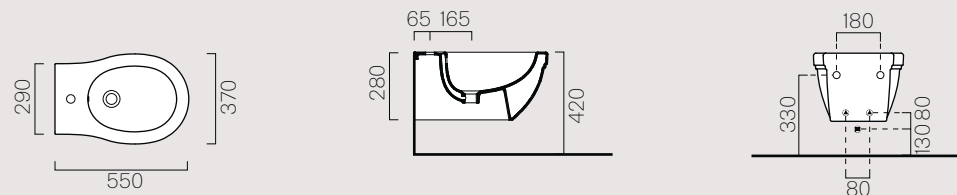

**54x37
871011**

Description	Wc
Code	871011
Dimensions	54x37
Weight	Kg 22,5
Flush system	Standard
Installation	Floor standing

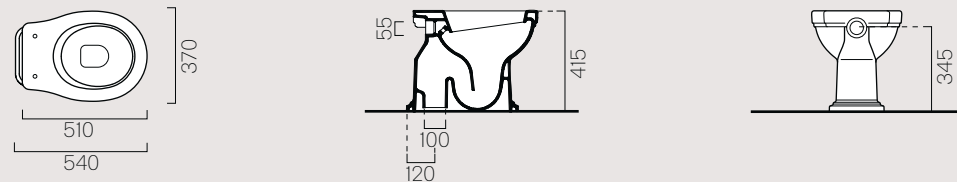

**54x37
871111**

Description	Wc
Code	871111
Dimensions	54x37
Weight	Kg 22,5
Flush system	Standard
Installation	Floor standing



**54x37
8762111**

Description	Bidet
Code	8762111
Dimensions	54x37
Weight	Kg 18,2
Overflow	CL 25
Installation	Floor standing
Taphole	1(3)

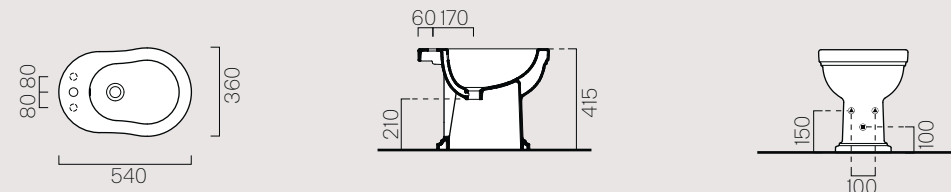

**70x37
871711**

Description	Wc
Code	871711
Dimensions	70x37
Weight	Kg 25,2
Flush system	Standard
Installation	Floor standing

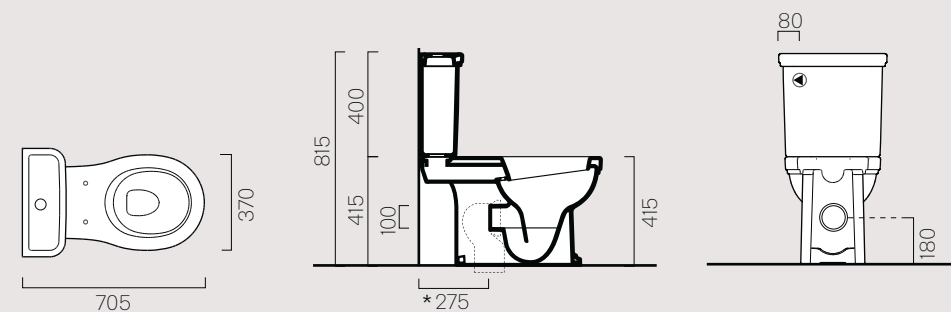

Curva tecnica /
Technical curve

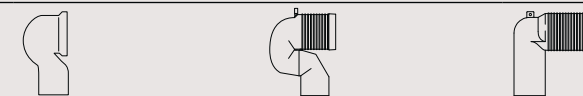

Codice / Codes	MCURVA	MCURVAS	MCURVA90
Interasse / Distance	*275	*Da 250 a 320 mm *From 250 to 320 mm	*Da 80 a 230 mm *From 80 to 230 mm

Cassetta/Cistern 878111

Description	Cistern
Code	878111
Dimensions	17x42 h40
Weight	Kg 13,6

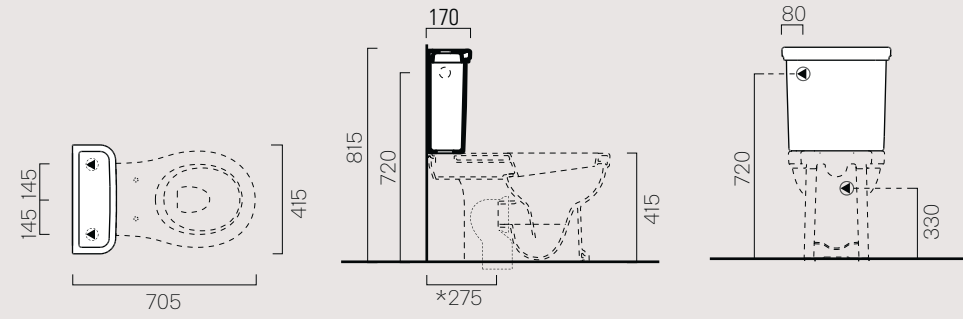

Cassetta/Cistern 879011

Description	Cistern
Code	879011
Dimensions	46x22 h41
Weight	Kg 16,5

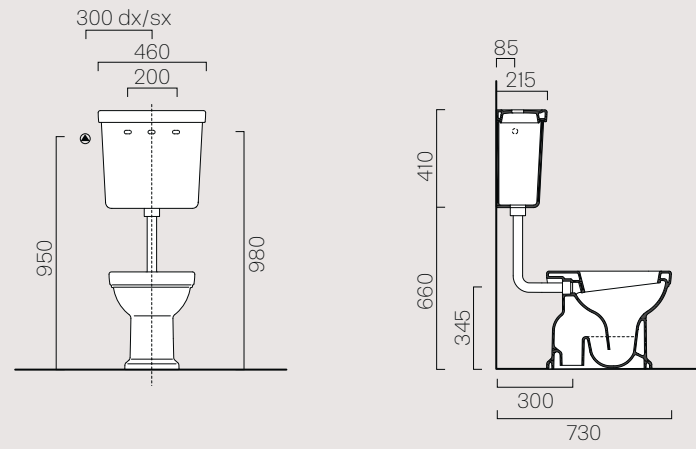

Cassetta/Cistern 878011

Description	Cistern
Code	878011
Dimensions	46x22 h41
Weight	Kg 16,5

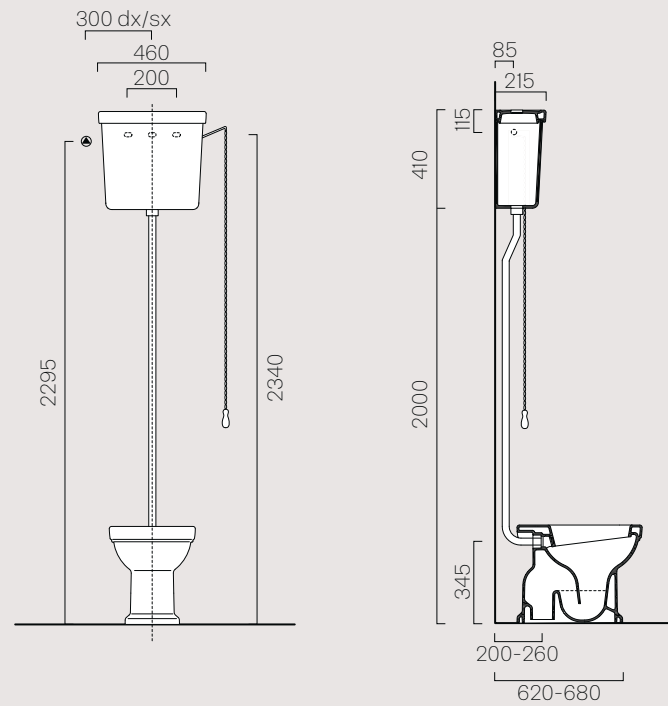



IT La collezione City declina differenti misure di lavabi installabili a sospensione o su mobile. I sanitari sono disponibili per installazione a pavimento o a sospensione, con copriwater sottili ad estrazione rapida Quick Release, sistema di chiusura Soft Close e sistema di scarico Save Water a 4,5 litri. Selezionati modelli di wc sospesi e a terra utilizzano la qualità tecnica ed efficienza del sistema di scarico Swirlflush®.

EN The City collection features washbasins of different sizes that can be mounted on walls or on cabinets. Sanitary ware are available for floor or wall installation with slender toilet seats using the Quick Release mechanism, the Soft-Close closure system and the 4.5 litre Save Water flushing system. Select models of wall mounted and floor standing Wcs use the technical features and efficiency of the Swirlflush® flushing system.

DE Die Kollektion City vereint unterschiedliche Größen von Waschtischen, die wandhängend oder Möbel montiert werden können. Die Sanitärmöbel sind für Boden- oder Wandanbringung erhältlich, weisen dünne Toilettensitze mit Take-off System, Soft-Close-System und Save Water-System zu 4,5 L auf. Ausgewählte Wand- und Boden-WC-Modelle sind mit der technischen Raffinesse und Effizienz des Spülsystems Swirlflush® ausgestattet.

58x45
Lavabo / Washbasin / Waschbecken

City

64x48
913111
p.336



58x45
913011
p.336



61x52
MASIAN111
p.338



57x47
MALISEON111
p.338



57x42
MVULCN11
p.340



52x35/F
911511
916411
p.342



52x35/F
911011
916211
p.346



52x35/F
911611
916411
p.344





80×50
Lavabo / Washbasin / Waschbecken



52×35
Wc e bidet / Wc and bidet / Wc und Bidet

336 Lavabo con foro troppopieno e monoforo per rubinetteria, predisposto per tre fori. Installazione a sospensione, ad incasso / Washbasin with overflow and one taphole for tap fittings, designed for three tapholes. Wall-hung or built-in installation / Waschtisch mit Überlauf und Hahnlochbefestigung für drei Löcher. Für Wand- oder Einbaumontage

Opzione colore / Color options / Faberoption

Bianco lucido

Installazione / Installation / Installation

Sospensione / Wall-hung / Wanshängend

Incasso / Built-in / Einbaumontage

64×48
913111



58×45
913011



extraglazeantibacterial®

64×48
Lavabo / Washbasin / Waschbecken



338 Lavabo con foro troppopieno e monoforo per rubinetteria, predisposto per tre fori. Installazione ad incasso / Washbasin with overflow and single taphole for tap fittings, designed for three holes. Built-in installation / Waschtisch mit Überlauf und Hahnlochbefestigung für drei Löcher. Einbauinstallation

Opzione colore / Color options / Faberoption

Bianco lucido

Installazione / Installation / Installation

Incasso / Built-in / Einbaumontage

61x52

MASIAN111



57x47

MALISEON111



extraglazeantibacterial®



57x47
Lavabo / Washbasin / Waschbecken

340 Lavabo con foro troppopieno predisposto per rubinetteria a parete o su piano.
 Installazione sottopiano /
 Washbasin with overflow designed for wall or countertop tap fittings.
 Undercounter installation /
 Waschtisch mit Überlauf, geeignet für Wand- oder Standarmaturen.
 Unterbaubefestigung

Opzione colore / Color options / Faberoption

Bianco lucido

Installazione / Installation / Installation

Sottopiano / Undercounter / Underbau

57×42

MVULCN11



extraglazeantibacterial®



57×42
 Lavabo / Washbasin / Waschbecken

342 Wc sospeso con sistema di scarico Swirlflush®. Bidet sospeso con foro troppopieno e monoforo per rubinetteria /
Wall-hung wc with Swirlflush® flushing system. Wall-hung bidet with overflow and one taphole for tap fittings /
WC wandhängend mit Spülsystem Swirlflush® Bidet wandhängend mit Überlauf und Hahnlochbefestigung

Opzione colore / Color options / Faberoption

Bianco lucido

52x35/F
911511



52x35
916411



extraglazeantibacterial®



swirlflush®



quickrelease



softclose

52x35/F
Wc e bidet / Wc and bidet / Wc und Bidet



344 Wc sospeso con sistema di scarico Swirflush® e fissaggio a vista. Bidet sospeso con foro troppopieno e monoforo per rubinetteria. Fissaggio dal basso / Wall-hung wc with Swirflush® flushing system and fixtures visible. Wall-hung bidet with overflow and single taphole for tap fittings. Concealed fixtures / WC wandhängend mit Spülsystem Swirflush® und oder sichtbarer Befestigung. Bidet wandhängend mit Überlauf und Hahnlochbefestigung. Verdeckte Befestigung

Opzione colore/Color options/Faberoption

Bianco lucido

52x35/F
911611



52x35
916411



extraglazeantibacterial®



swirlflush®



quickrelease



softclose

52x35/F
Wc e bidet / Wc and bidet / Wc und Bidet

346 Wc a terra predisposto per scarico a parete oppure a pavimento tramite curva tecnica con sistema di scarico Swirflush®.
Bidet a terra con foro troppopieno e monoforo per rubinetteria /
Floor standing wc designed for wall outlet or floor outlet using S-curve plumbing with Swirflush® flushing system. Floor standing bidet with overflow and single taphole for tap fittings /
WC in Bodeninstallation für horizontalem oder Bodenablauf mittels Anschlussbogen mit Spülsystem Swirflush®. Bidet in Bodenmontage mit Überlauf und Hahnlochbefestigung

Opzione colore / Color options / Faberoption

Bianco lucido

52x35/F
911011



52x35
916211



extraglazeantibacterial®



swirlflush®



quickrelease



softclose

52x35/F
Wc e bidet / Wc and bidet / Wc und Bidet



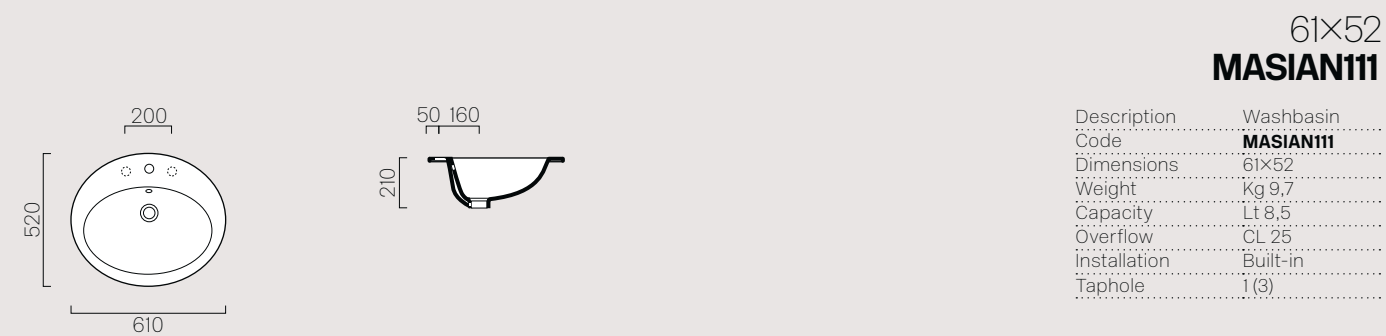
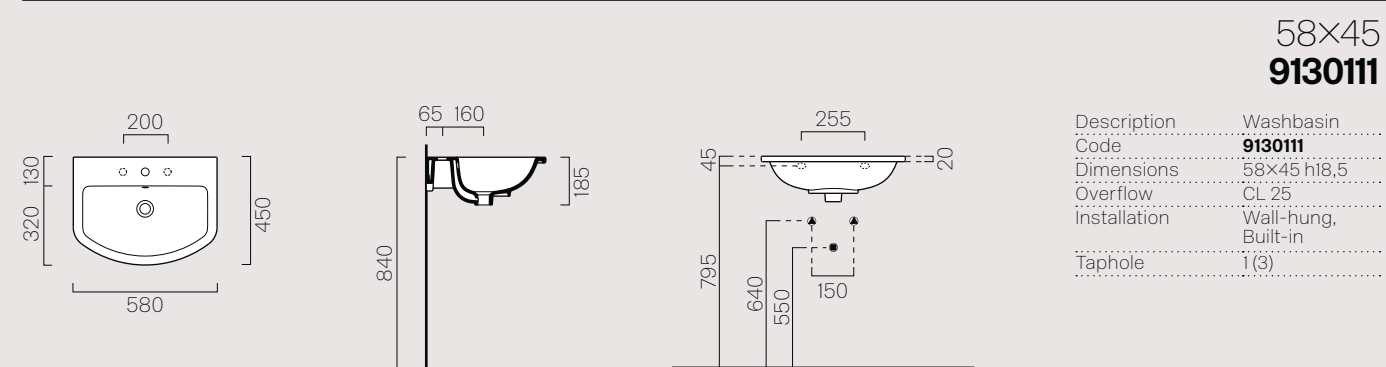
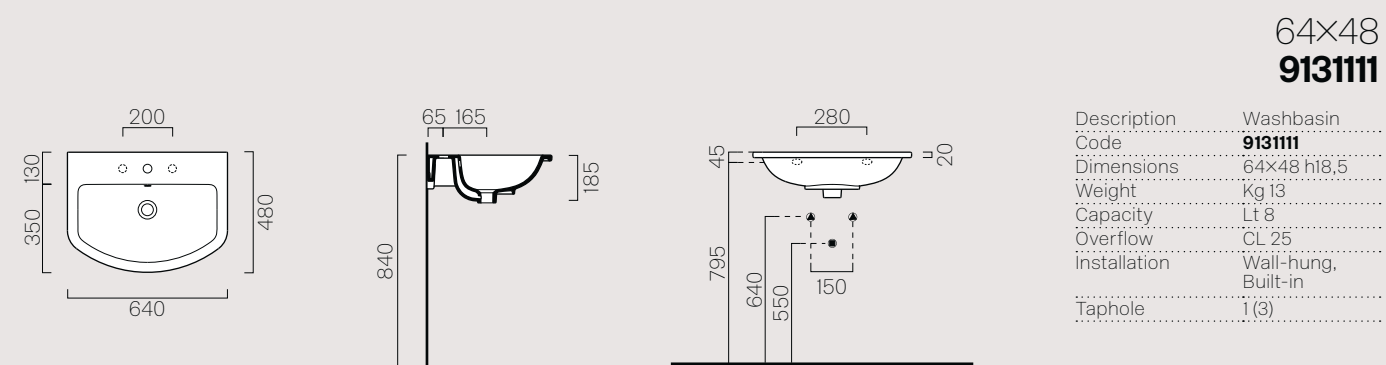

57x47 MALISEON111

Description	Washbasin
Code	MALISEON111
Dimensions	57x47
Weight	Kg 8,4
Capacity	Lt 4,5
Overflow	CL 25
Installation	Built-in
Taphole	1(3)

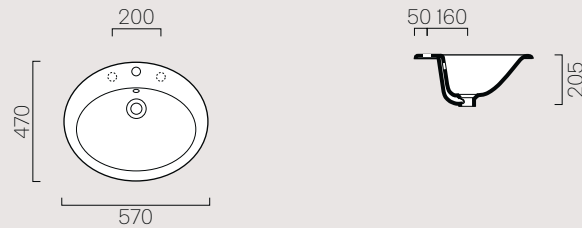

57x42 MVULCN11

Description	Washbasin
Code	MVULCN11
Dimensions	57x42
Weight	Kg 7
Capacity	Lt 7
Overflow	CL 25
Installation	Built-in
Taphole	0



Wc e Bidet / Wc and Bidet / Wc und bidet

52x35/F 911511

Description	Wc
Code	911511
Dimensions	52x35
Weight	Kg 21,8
Flush system	Swirflush®
Installation	Wall-hung

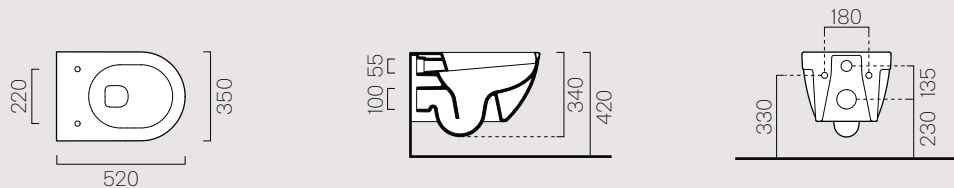

Non è consigliato l'impiego di cassette di scarico esterne o impianti dotati di rubinetto flussometro /
We do not recommend the use of external flushing cisterns or systems endowed with flushometer valves /
Empfohlen wird die Verwendung eines externen Spülkastens oder einer Selbstschlussarmatur

52x35/F 911611

Description	Wc
Code	911611
Dimensions	52x35
Weight	Kg 22
Flush system	Swirflush®
Installation	Wall-hung

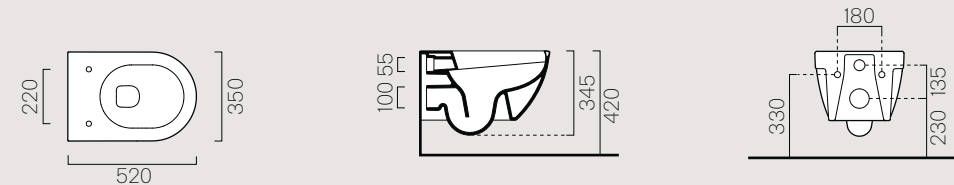

Non è consigliato l'impiego di cassette di scarico esterne o impianti dotati di rubinetto flussometro /
We do not recommend the use of external flushing cisterns or systems endowed with flushometer valves /
Empfohlen wird die Verwendung eines externen Spülkastens oder einer Selbstschlussarmatur

52x35 9164111

Description	Bidet
Code	9164111
Dimensions	52x35
Weight	Kg 15,2
Overflow	CL 25
Installation	Wall-hung
Taphole	1

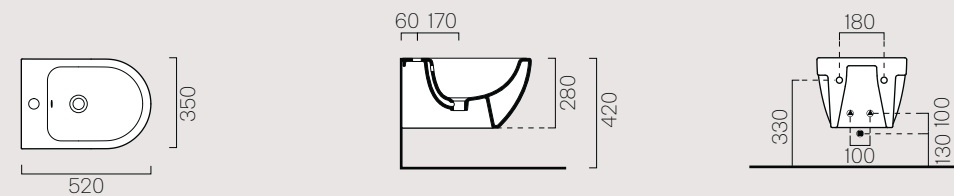

52x35/F 911011

Description	Wc
Code	911011
Dimensions	52x35
Weight	Kg 25,4
Flush system	Swirflush®
Installation	Floor outlet

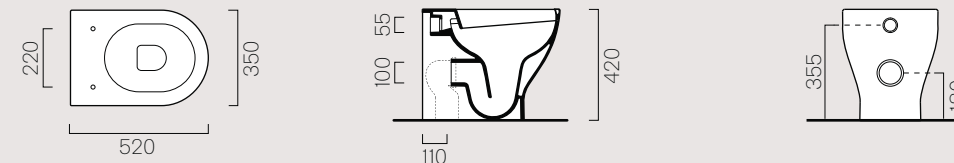

Non è consigliato l'impiego di cassette di scarico esterne o impianti dotati di rubinetto flussometro /
We do not recommend the use of external flushing cisterns or systems endowed with flushometer valves /
Empfohlen wird die Verwendung eines externen Spülkastens oder einer Selbstschlussarmatur

52x35 9162111

Description	Bidet
Code	9162111
Dimensions	52x35
Weight	Kg 20
Overflow	CL 25
Installation	Floor outlet
Taphole	1

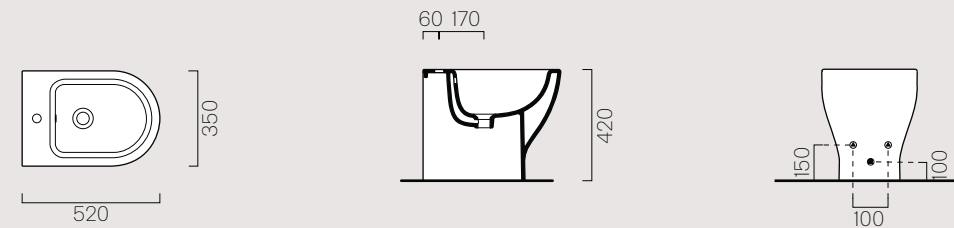



IT Community è la proposta GSI per l'ambiente bagno pubblico e collettivo. La collezione prevede una linea di prodotti per un'utenza con mobilità ridotta. Completano la collezione bidet e wc ad installazione a sospensione con sistema di scarico Swirlflush® e diversi modelli di orinatoio. I prodotti sono rifiniti con Extraglaze Antibacterial, lo smalto arricchito con ioni di Argento e Titanio che riduce la carica batterica del 99,99%.

EN Community is GSI Ceramica's proposal for public or collective bathroom environments. The collection features a line of products designed for people with reduced mobility and is completed by a bidet and a wall mounted Wc with the Swirlflush® flushing system and different models of urinals. The products are covered with Extraglaze Antibacterial glaze, a special finishing with silver and titanium ions that reduces bacteria counts by 99.99%.

DE Mit Community stellt GSI ein Angebot für Baderäume von Gewerbe- und Büroflächen vor. Teil der Kollektion ist eine Produktlinie für Benutzer mit eingeschränkter Mobilität. Wandhängende Bidets und WCs mit Swirlflush®-Spülsystem sowie unterschiedliche Urinal-Modelle runden die Kollektion ab. Alle Produkte sind mit Extraglaze Antibacterial-Glasur veredelt, eine mit Silber- und Titan-Ionen angereicherte Glasur, die das Bakterienaufkommen um 99,99% reduziert.

70x55
Lavabo / Washbasin / Waschbecken

Community

70×55
7633011
p.358



60×55
7635011
p.358



70×36/F
761511
p.360



35×31/R*
909711
p.362



35×31/R*
909811
p.362



30×30/R*
769511
p.364



30×30/R*
769611
p.364



39×31
769711
p.366



39×31
769811
p.366



36×25
889711
p.366



120×90
439511
p.380



120×80
439811
p.382



120×70
439911
p.384



100×90
439211
p.380



100×80
438511
p.382



100×70
438911
p.384



90×90
439411
p.380



80×80
438411
p.382



90×72
438811
p.384



*Disponibile anche in Bianco opaco, Cenere e Ardesia /
Also available Bianco opaco, Cenere and Ardesia /
Erhältlich in Bianco opaco Cenere and Ardesia

.....
Lato non smaltato /
Not glazed side /
Nicht Glasierte seite



70x55
Lavabo / Washbasin / Waschbecken

70x36/F
Wc

Lavabo antibatterico con foro troppopieno o senza foro troppopieno (art. 7632011 - 7634011) predisposto per rubinetteria monoforo o a parete.
 Installazione a sospensione /
 Anti-bacterial washbasin with overflow or without overflow (art. 7632011 - 7634011) designed for single taphole fitting or on wall.
 Wall-hung installation /
 Antibakterieller Waschtisch mit Überlauf, oder ohne Überlauf (art. 7632011 - 7634011) geeignet für Armaturen mit Hahnloch- oder Wandbefestigung. Wandhängend

Opzione colore/Color options/Faberoption

Bianco lucido

Installazione/Installation/Installation

Sospensione/Wall-hung/Wandhängend

70x55
7633011
7632011



60x55
7635011
7634011



 extraglazeantibacterial®



70x55
 Lavabo / Washbasin / Waschbecken

Opzione colore/Color options/Faberoption

Bianco lucido

70x36/F
761511



70x36/F
Wc



35x31/R Ardesia
Orinatoio/Urinal/Urinal

Orinatoio sospeso con e senza fori per fissaggio del coperchio. Disponibile nelle finiture Color Elements Bianco opaco, Ardesia e Cenere / Wall-mounted urinal with or without holes for cover fixing. Available in Color Elements finishings Matt White, Ardesia and Cenere / Urinal wandhängend mit oder ohne Löchern für die Deckelmontage. Erhältlich in den Ausführungen Color Elements Bianco matt, Ardesia und Cenere

Opzione colore /Color options /Faberoption

- Bianco lucido
- Bianco opaco
- Ardesia
- Cenere

35x31/R
909711



35x31/R
909811



Solo per /
Only for /
Nur für
Bianco lucido



35x31/R
Orinatoio/Urinal/Urinal

364 Orinatoio sospeso con e senza fori per fissaggio del coperchio. Disponibile nelle finiture Color Elements Bianco opaco, Ardesia e Cenere / Wall-mounted urinal with or without holes for cover fixing. Available in Color Elements finishings Matt White, Ardesia and Cenere / Urinal wandhängend mit oder ohne Löchern für die Deckelmontage. Erhältlich in den Ausführungen Color Elements Bianco matt, Ardesia und Cenere

Opzione colore / Color options / Faberoption

- Bianco lucido
- Ardesia
- Bianco opaco
- Cenere

30×30/R
769511



30×30/R
769611



Solo per /
Only for /
Nur für
Bianco lucido



30×30/R
Orinatoio/Urinal/Urinal



366 Orinatoio sospeso con o senza fori per fissaggio del coperchio /
Wall-mounted urinal with or without holes for cover fixing /
Urinal wandhängend mit oder ohne Löchern für die Deckelmontage

Opzione colore/Color options/Faberoption

Bianco lucido

39×31
769711



39×31
769811



36×25
889711



39×31
Orinatoio/Urinal/Urinal

70×55
7633011

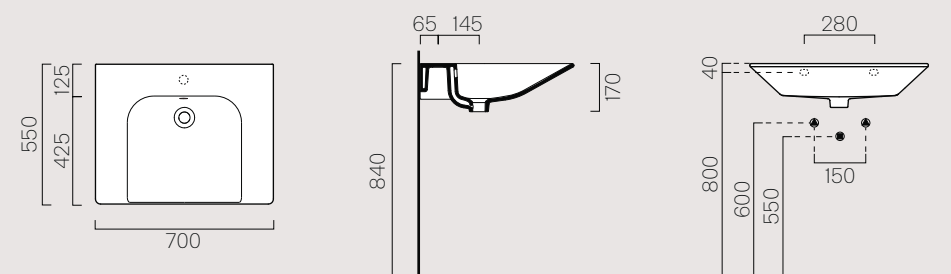

Description	Washbasin
Code	7633011
Dimensions	70×55 h17
Weight	Kg 16,3
Capacity	Lt 7
Overflow	CL 25
Installation	Wall-hung,
Taphole	0 (1,3)

70×55
7632011

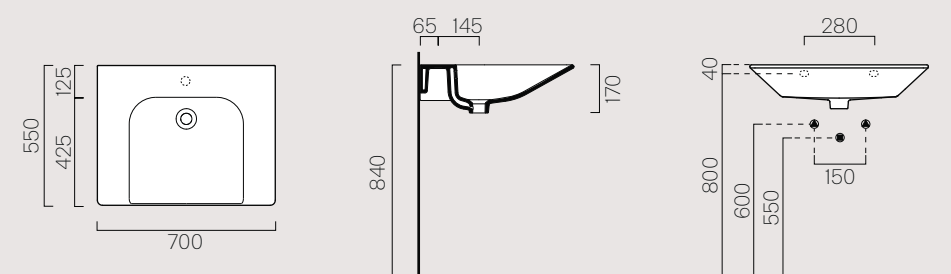

Description	Washbasin
Code	7632011
Dimensions	70×55 h17
Weight	Kg 16,3
Capacity	Lt 7
Overflow	CL 00
Installation	Wall-hung,
Taphole	0 (1,3)

60×55
7635011

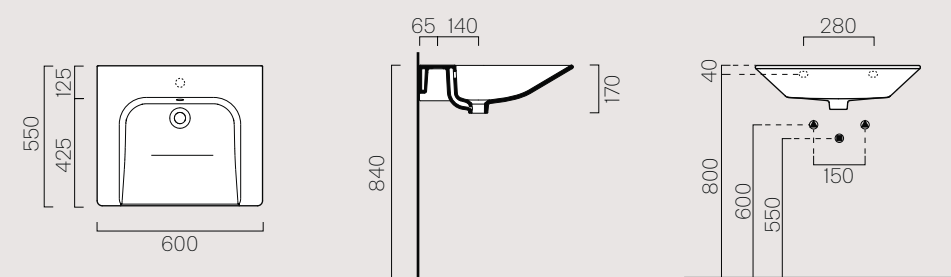

Description	Washbasin
Code	7635011
Dimensions	60×55 h17
Weight	Kg 14,5
Capacity	Lt 6
Overflow	CL 25
Installation	Wall-hung,
Taphole	0 (1,3)

60×55 7634011

Description	Washbasin
Code	7634011
Dimensions	60×55 h17
Weight	Kg 14,5
Capacity	Lt 6
Overflow	CL 00
Installation	Wall-hung,
Taphole	0 (1,3)

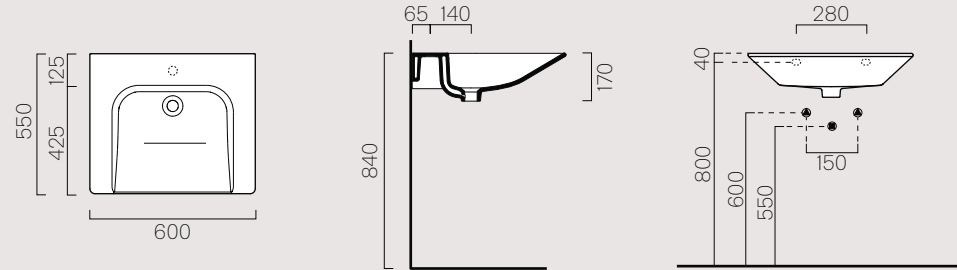

Wc e Bidet/Wc and Bidet/Wc und bidet

70×36/F 761511

Description	Wc
Code	761511
Dimensions	70×36
Weight	Kg 33,7
Flush system	Swirlflush®
Installation	Wall-hung

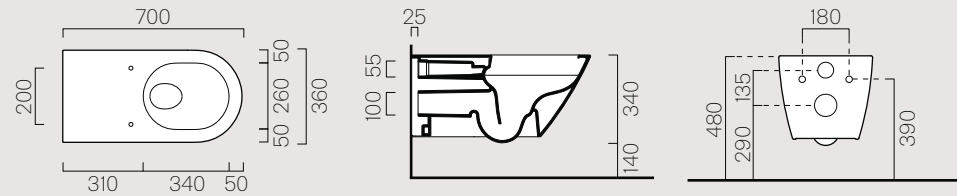

Non è consigliato l'impiego di cassette di scarico esterne o impianti dotati di rubinetto flussometro /
We do not recommend the use of external flushing cisterns or systems endowed with flushometer valves /
Empfohlen wird die Verwendung eines externen Spülkastens oder einer Selbstschlussarmatur

Orinatoio/Urinal/Urinal

35×31/R 909711 / 909811

Description	Urinal
Code	909711 909811
Dimensions	35×31 h66
Weight	Kg 19

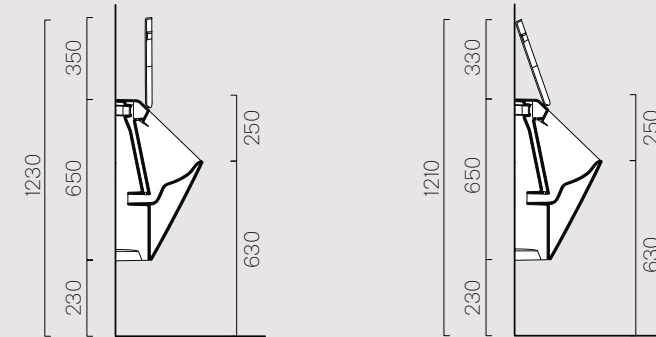
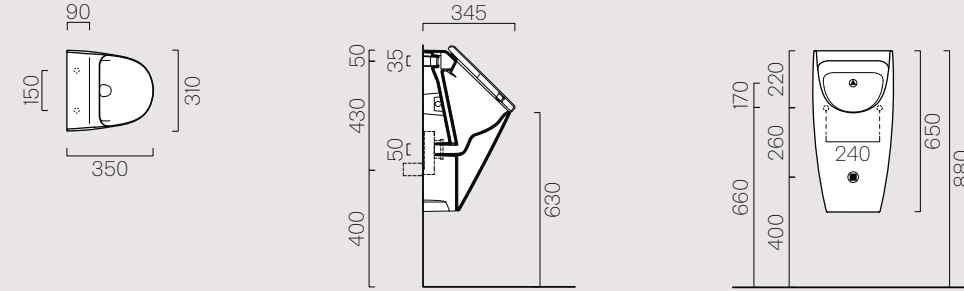

30×30/R 769511 / 769611

Description	Urinal
Code	769511 769611
Dimensions	30×30 h54
Weight	Kg 10,5

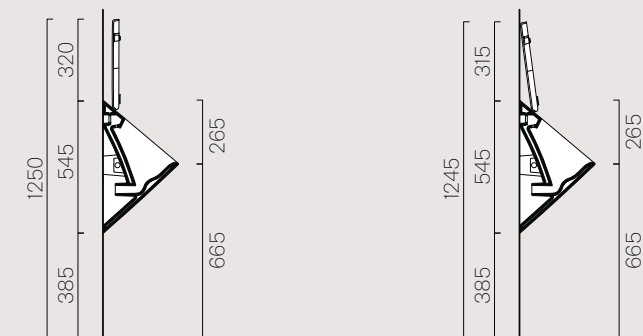
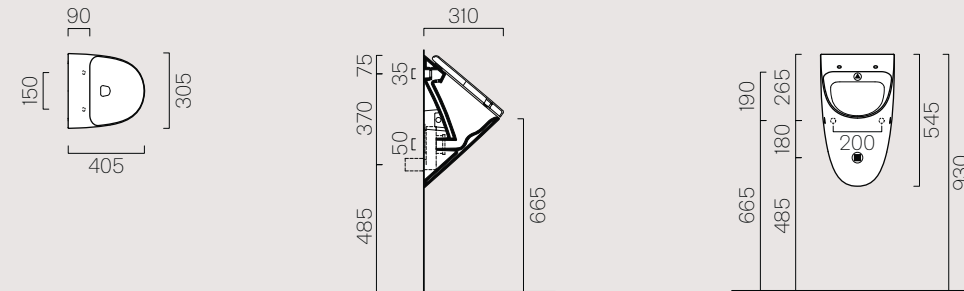

39x31 769711 / 769811

Description	Urinal
Code	769711 769811
Dimensions	39x31 h60
Weight	Kg 12,4
Flush system	Standard
Installation	Wall-hung

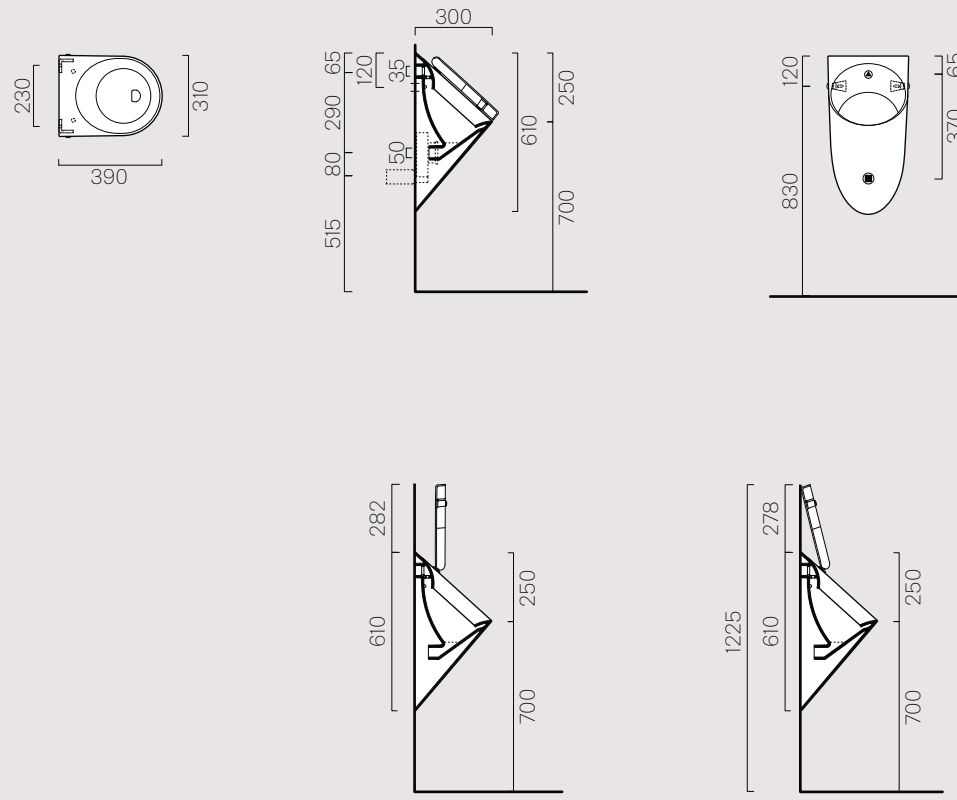

36x25 889711

Description	Urinal
Code	889711
Dimensions	36x25 h60
Weight	Kg 9,8

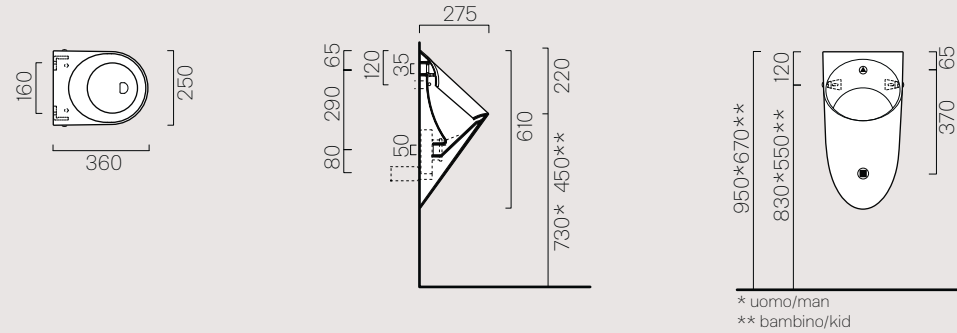

IT I piatti doccia GSI sono in ceramica o nell'innovativo materiale composito Compstone. I piani in ceramica si presentano nell'unico spessore di 4,5 cm. I piatti doccia Compstone si adattano alle più svariate possibilità di personalizzazione di forma, dimensione e colore. Tutti piatti doccia possono essere installati a filo pavimento o in appoggio, sono caratterizzati da texture antiscivolo che ricorda la pietra naturale o motivi in rilievo sulla ceramica.

EN GSI's shower trays are in ceramic or in the innovative composite material Compstone. The ceramic bases have a single thickness of 4.5 cm. Compstone shower trays lend themselves to the most varied possibilities of personalization in terms of shape, size and color. All shower trays may be installed flush with the floor or on support and feature antislip textures that are reminiscent of natural stone or raised motifs on the ceramic surface.

DE Die Duschbecken von GSI sind aus Keramik oder aus dem neuartigen Verbundmaterial Compstone gefertigt. Die Keramikbecken werden in der Einheitsstärke 4,5 cm angeboten. Compstone-Duschplatten passen sich den verschiedensten Personalisierungswünschen an Form, Größe und Farbe an. Alle Duschbecken können in flächenbündiger Boden- oder Wandanbringung installiert werden und weisen rutschfeste Texturen in Naturstein-Geschmack oder hervorgehobene Keramikmuster auf.

Piatti doccia

120x90
439511
p.380



100x70
438911
p.384



120x80
439811
p.382

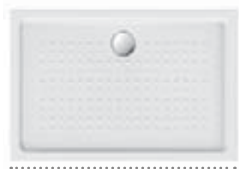

90x90
439411
p.380



120x70
439911
p.384



80x80
438411
p.382



100x90
439211
p.380



90x72
438811
p.384



100x80
438511
p.382



210→120x**120**
p.394



210→90x**90**
p.394



210→110x**110**
p.394



210→80x**80**
p.394

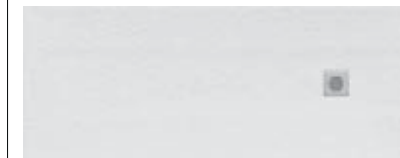

210→100x**100**
p.394



210→70x**70**
p.394

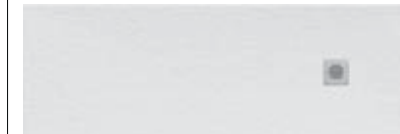

.....
Lato non smaltato/
Not glazed side/
Nicht Glasierte seite



90×90
Piatto doccia / Shower tray / Duschwanne

Nubes 180×80
Vasca / Bathtub / Badewanne

380 Piatto doccia con antiscivolo a rilievo ceramico. Installazione ad appoggio o a filo pavimento / Shower tray with ceramic anti-slip. Free-standing or flush-fitting installation / Duschbecken mit Anti-Rutsch-Keramik. Für Aufsatz- oder flächenbündige Bodeninstallation

Opzione colore/Color options/Faberoption

- Bianco lucido
- Bianco opaco

Installazione/Installation/Installation

- Appoggio/Countertop/Aufsatzwaschbecken
- Filo pavimento/Flush-fitting/Eingepasste Montage

120×90
439511



100×90
439211



90×90
439411



extraglazeantibacterial®

120×90
Piatto doccia/Shower tray/Duschwanne



382 Piatto doccia con antiscivolo a rilievo ceramico. Installazione ad appoggio o a filo pavimento / Shower tray with ceramic anti-slip. Free-standing or flush-fitting installation / Duschbecken mit Anti-Rutsch-Keramik. Für Aufsatz- oder flächenbündige Bodeninstallation

Opzione colore/Color options/Faberoption

- Bianco lucido
- Bianco opaco

Installazione/Installation/Installation

- Appoggio/Countertop/Aufsatzwaschbecken
- Filo pavimento/Flush-fitting/Eingepasste Montage

120×80
439811



100×80
438511



80×80
438411



extraglazeantibacterial®



120×80
Piatto doccia/Shower tray/Duschwanne

Piatto doccia con antiscivolo a rilievo ceramico. Installazione ad appoggio o a filo pavimento / Shower tray with ceramic anti-slip. Free-standing or flush-fitting installation / Duschbecken mit Anti-Rutsch-Keramik. Für Aufsatz- oder flächenbündige Bodeninstallation

Opzione colore/Color options/Faberoption

- Bianco lucido
- Bianco opaco

Installazione/Installation/Installation

- Appoggio/Countertop/Aufsatzwaschbecken
- Filo pavimento/Flush-fitting/Eingepasste Montage

120×70
439911



100×70
438911



90×72
438811





extraglazeantibacterial®

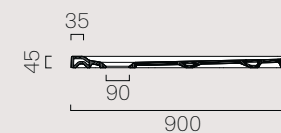
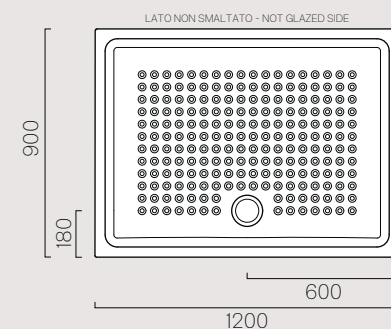

100×70
Piatto doccia/Shower tray/Duschwanne

120x90
439511



Description	Shower tray
Code	439511
Dimensions	120x90 h4,5
Weight	Kg 45,5
Installation	Freestanding, Flush-fitting
Material	Ceramic

120x80
439811

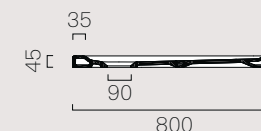
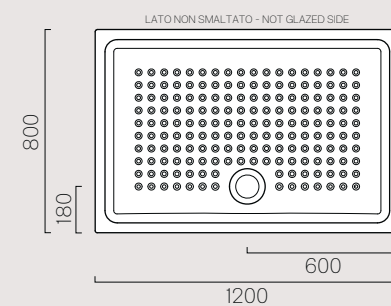

Description	Shower tray
Code	439811
Dimensions	120x80 h4,5
Weight	Kg 41,1
Installation	Freestanding, Flush-fitting
Material	Ceramic

120x70
439911

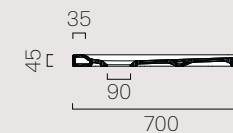
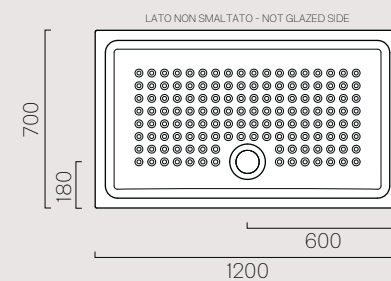

Description	Shower tray
Code	439911
Dimensions	120x70 h4,5
Weight	Kg 36,8
Installation	Freestanding, Flush-fitting
Material	Ceramic

100x90 439211

Description	Shower tray
Code	439211
Dimensions	100x90 h4,5
Weight	Kg 42
Installation	Freestanding, Flush-fitting
Material	Ceramic

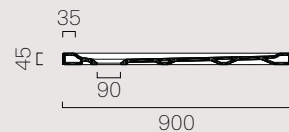
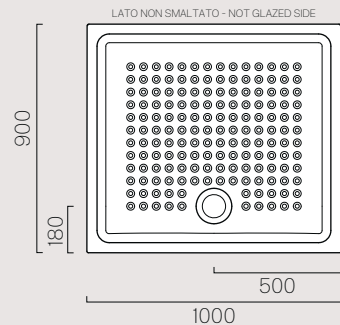

80x80 438411

Description	Shower tray
Code	438411
Dimensions	80x80 h4,5
Weight	Kg 28,8
Installation	Freestanding, Flush-fitting
Material	Ceramic

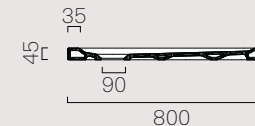
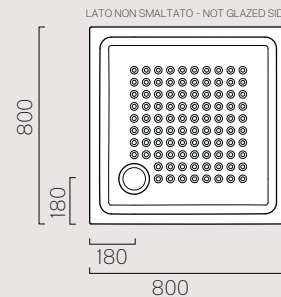

100x80 438511

Description	Shower tray
Code	438511
Dimensions	100x80 h4,5
Weight	Kg 34,4
Installation	Freestanding, Flush-fitting
Material	Ceramic

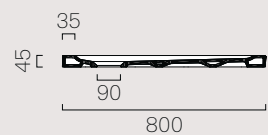
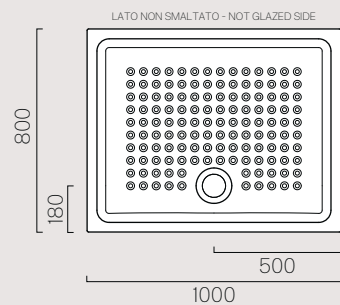

90x72 438811

Description	Shower tray
Code	438811
Dimensions	90x72 h4,5
Weight	Kg 27,9
Installation	Freestanding, Flush-fitting
Material	Ceramic

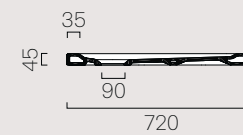
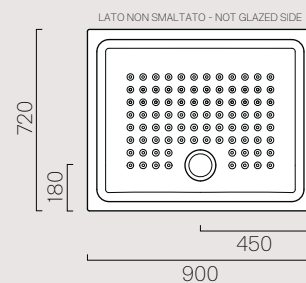

100x70 438911

Description	Shower tray
Code	438911
Dimensions	100x70 h4,5
Weight	Kg 29
Installation	Freestanding, Flush-fitting
Material	Ceramic

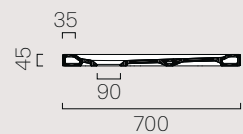
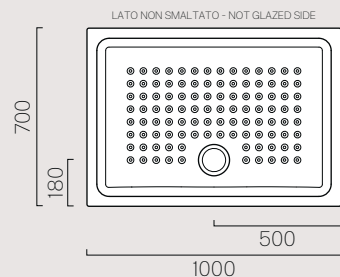

90x90 439411

Description	Shower tray
Code	439411
Dimensions	90x90 h4,5
Weight	Kg 36,5
Installation	Freestanding, Flush-fitting
Material	Ceramic

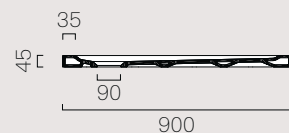
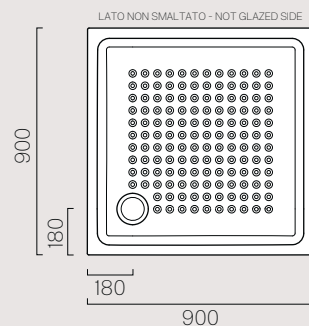



Compstone Cenere
Piatto doccia / Shower tray / Duschwanne

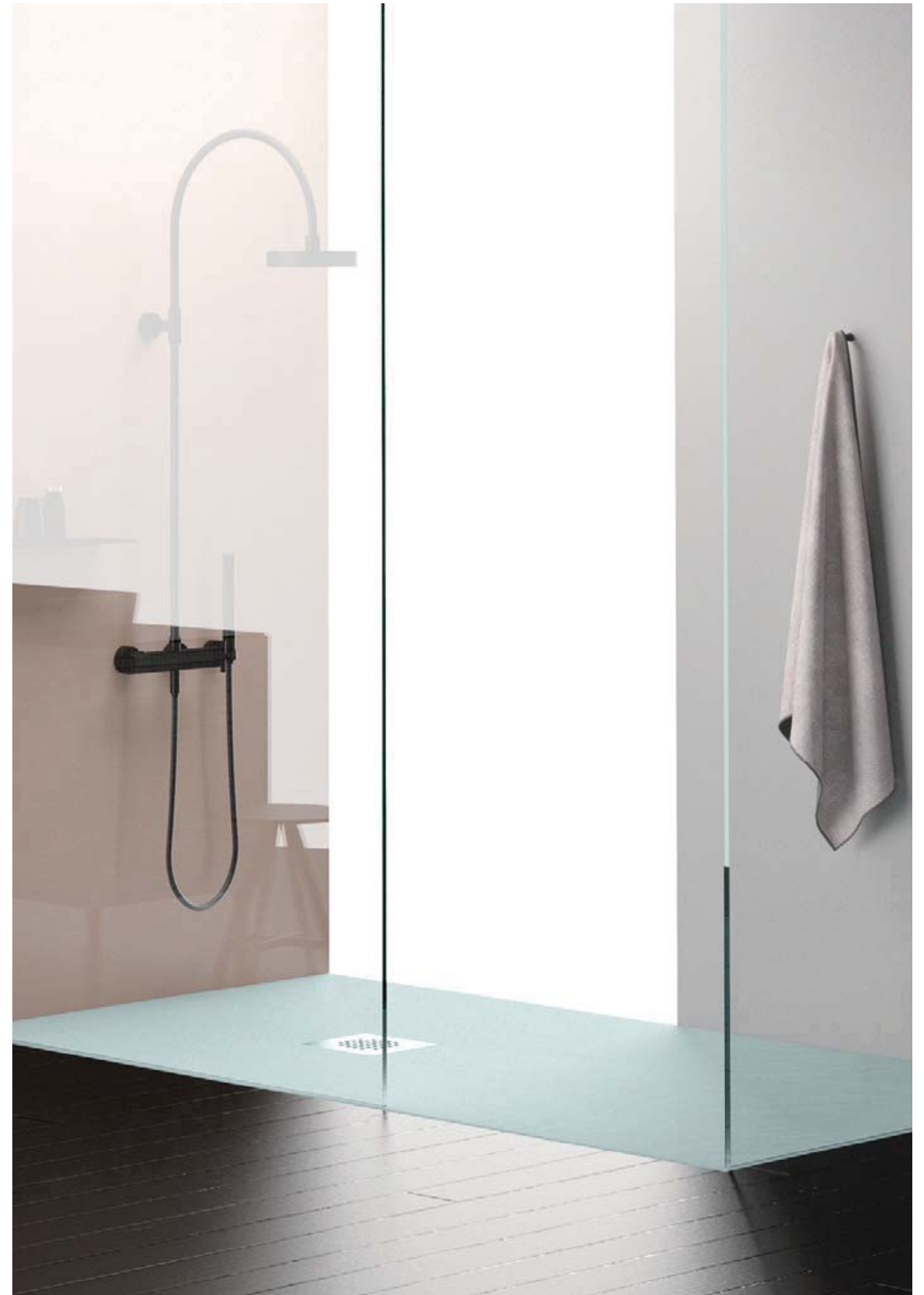

Compstone Ghiaccio
Piatto doccia / Shower tray / Duschwanne



Compstone Agave
Piatto doccia / Shower tray / Duschwanne



Compstone Ghiaccio
Piatto doccia / Shower tray / Duschwanne



Altamente resistente, non poroso, omogeneo, Compstone combina le proprietà meccaniche di pietra e resina a vantaggio della lavorabilità del prodotto. Si presta in modo ottimale alla **fresatura** e al **taglio** per ottenere dimensioni particolari con grado di precisione al millimetro. Quando incassato gli angoli perfettamente a 90° su tutti i bordi garantiscono una posa impeccabile a filo pavimento. La sofisticata superficie materica che ricorda la pietra naturale garantisce la massima sicurezza con la texture antiscivolo, e una piacevole, calda sensazione al contatto con il piede. Disponibile in tutti i colori della nostra Collezione Color Elements oppure, a richiesta, in tutte le gradazioni della gamma RAL /

Compstone is highly resistant, non-porous and homogeneous. It has the mechanical properties of both stone and resin, making the product more workable. This facilitates **trimming** and **cutting**, making it possible to obtain extremely accurate sizes even when walls are not perfectly straight. When all corners are at a perfect 90° angle, items can be installed perfectly flush with the floor. The sophisticated material surface, reminiscent of natural stone, ensures the utmost safety thanks to its non-slip texture and a pleasant, warm feeling for the feet. Available in all the shades of our Color Elements Collection or, on request, of the RAL range /

Opzione colore / Color options / Faberoption

- | | |
|--|--|
|  Bianco opaco |  Creta |
|  Agave |  Ghiaccio |
|  Ardesia |  Tortora |
|  Bistro |  RAL |
|  Cenere | |

Installazione / Installation / Installation

-  Appoggio / Countertop / Aufsatzwaschbecken
-  Filo pavimento / Flush-fitting / Eingepasste Montage

Personalizza il tuo piatto doccia / Customise your shower tray / Gestalten Sie Ihre Duschwanne individuell

Tutti i piatti doccia Compstone sono personalizzabili: è possibile eseguire tagli su misura per recuperare fuori squadra o per specifiche esigenze di forma e dimensioni nonché lavorazioni speciali per incasso di pareti in vetro. Essendo prodotto con materiale colorato in pasta, anche in corrispondenza di tagli o fresature, lo spessore presenterà le stesse caratteristiche di colore, impermeabilità e resistenza che troviamo in superficie.

Nel caso in cui il piano si scheggiasse o venisse rigato è disponibile un kit di ripristino /

All Compstone shower trays are customizable, and custom cuts can be made to compensate for non-straight walls or for specific shape and size needs as well as special works for glass wall mountings. As it is made with a colored paste material, the material will have the same color, impermeability and resistance properties on the surface and in cut or trimmed zones.

A repair kit is available should the tray be chipped or scratched / Sämtliche Compstone-Duschwannen lassen sich individuell gestalten: Es ist möglich das Material nach Maß zu schneiden, um die Duschwanne an abweichende Winkel oder besondere Formen und Abmessungen anzupassen oder um besondere Verarbeitungen zum Einbau von Glaswänden zu ermöglichen. Da das Material in der Masse gefärbt wird, weist es auch an Schnitt- oder Frässtellen die gleichen Eigenschaften bei Farbe, Wasserundurchlässigkeit und Beständigkeit auf, die an der Oberfläche gegeben sind.

Sollten an der Oberflächen Kratzer oder Absplitterungen entstehen, ist ein Reparaturkit erhältlich.

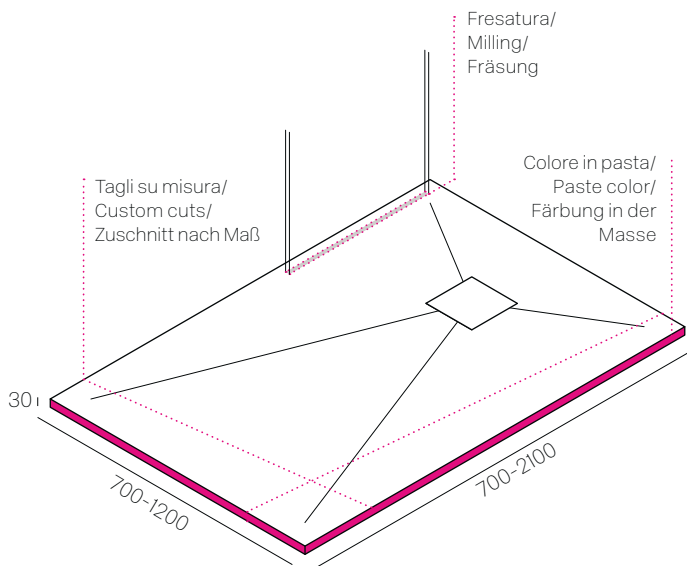

Per tutti i dettagli di codice, lavorazioni e personalizzazioni si rimanda al listino prezzi / Please consult the price list for all code, processing and customization details / Für sämtliche Details hinsichtlich Codes, Verarbeitung und Personalisierung wird auf die Preisliste verwiesen



Compstone Bianco opaco
Piatto doccia / Shower tray / Duschwanne

210→120×120

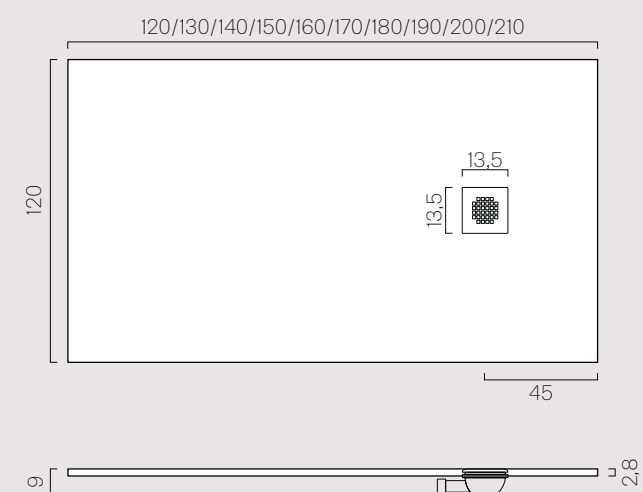

Description	Shower tray
Code	210x120 4221122 200x120 4220122 190x120 4219122 180x120 4218122 170x120 4217122 160x120 4216122 150x120 4215122 140x120 4214122 130x120 4213122 120x120 4212122
Installation	Freestanding, Flush-fitting
Material	Compstone

210→110×110

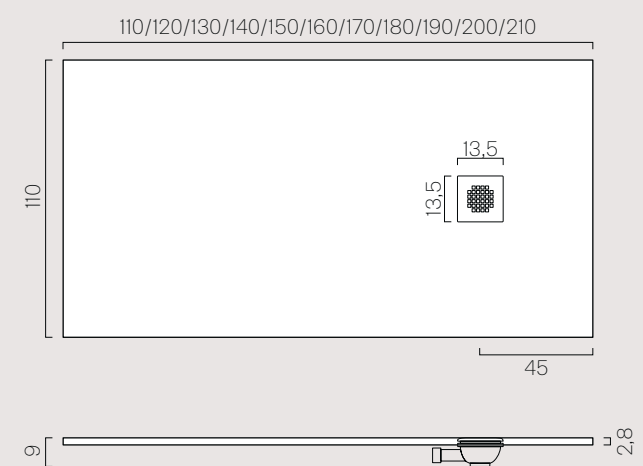

Description	Shower tray
Code	210x110 4221112 200x110 4220112 190x110 4219112 180x110 4218112 170x110 4217112 160x110 4216112 150x110 4215112 140x110 4214112 130x110 4213112 120x110 4212112 110x110 4211112
Installation	Freestanding, Flush-fitting
Material	Compstone

210→110×100

Description Shower tray
 Code 210x100 **4221102**
 200x100 **4220102**
 190x100 **4219102**
 180x100 **4218102**
 170x100 **4217102**
 160x100 **4216102**
 150x100 **4215102**
 140x100 **4214102**
 130x100 **4213102**
 120x100 **4212102**
 110x100 **4211102**

Installation Freestanding,
 Flush-fitting

Material Compstone

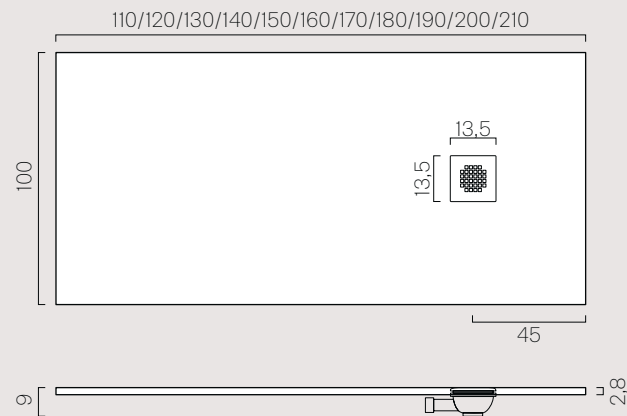

90×90

Description Shower tray
 Code 90x90 **4209092**

Installation Freestanding,
 Flush-fitting

Material Compstone

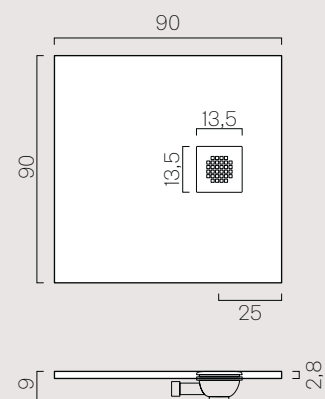

100×100

Description Shower tray
 Code 100x100 **4210102**

Installation Freestanding,
 Flush-fitting

Material Compstone

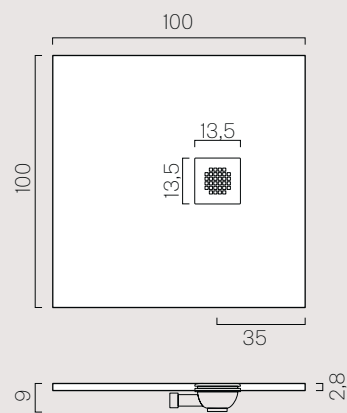

210→110×80

Description Shower tray
 Code 210x80 **4221082**
 200x80 **4220082**
 190x80 **4219082**
 180x80 **4218082**
 170x80 **4217082**
 160x80 **4216082**
 150x80 **4215082**
 140x80 **4214082**
 130x80 **4213082**
 120x80 **4212082**
 110x80 **4211082**

Installation Freestanding,
 Flush-fitting

Material Compstone

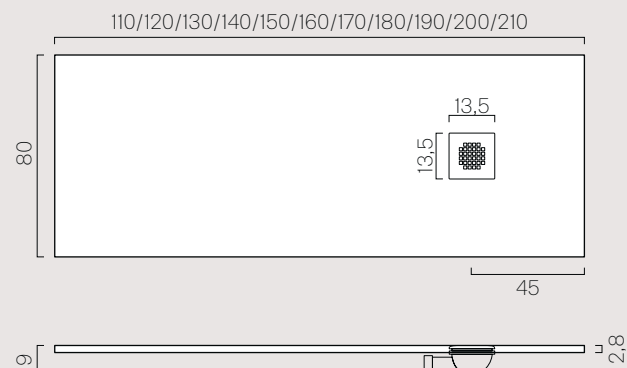

210→110×90

Description Shower tray
 Code 210x90 **4221092**
 200x90 **4220092**
 190x90 **4219092**
 180x90 **4218092**
 170x90 **4217092**
 160x90 **4216092**
 150x90 **4215092**
 140x90 **4214092**
 130x90 **4213092**
 120x90 **4212092**
 110x90 **4211092**

Installation Freestanding,
 Flush-fitting

Material Compstone

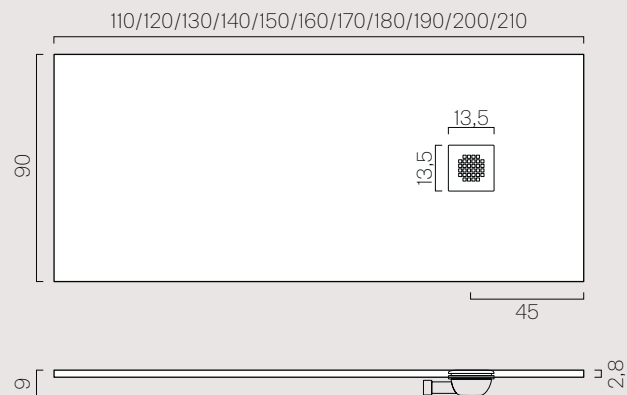

100×80

Description Shower tray
 Code 100x80 **4210082**

Installation Freestanding,
 Flush-fitting

Material Compstone

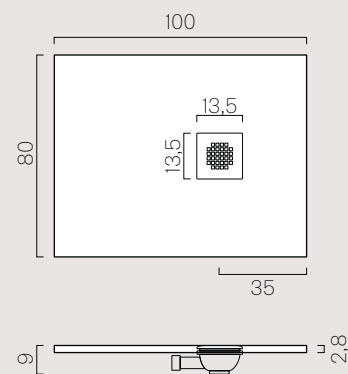

100×90

Description Shower tray
 Code 100x90 **4210092**

Installation Freestanding,
 Flush-fitting

Material Compstone

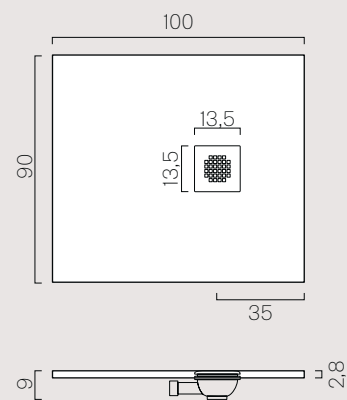

90→80×80

Description Shower tray
 Code 90x80 **4209082**
 80x80 **4208082**

Installation Freestanding,
 Flush-fitting

Material Compstone

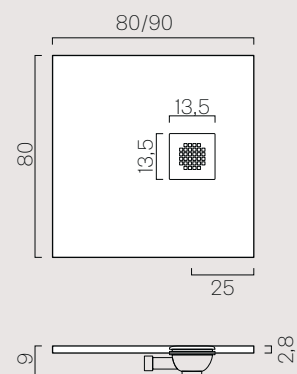

210→110×70

Description	Shower tray
Code	210x70 4221072 200x70 4220072 190x70 4219072 180x70 4218072 170x70 4217072 160x70 4216072 150x70 4215072 140x70 4214072 130x70 4213072 120x70 4212072 110x70 4211072
Installation	Freestanding, Flush-fitting
Material	Compstone

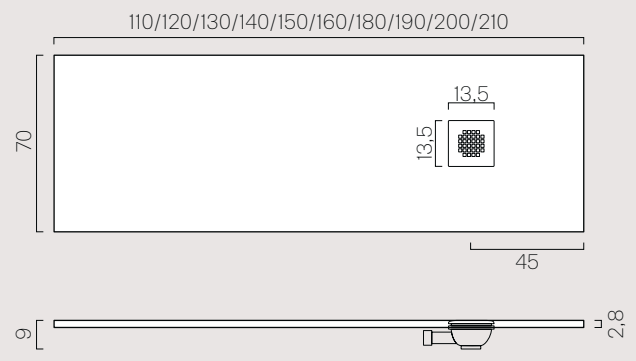

100×70

Description	Shower tray
Code	100x70 4210072
Installation	Freestanding, Flush-fitting
Material	Compstone

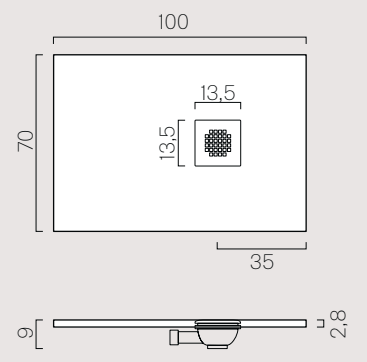

90→70×70

Description	Shower tray
Code	90x70 4209072 80x70 4208072 70x70 4207072
Installation	Freestanding, Flush-fitting
Material	Compstone

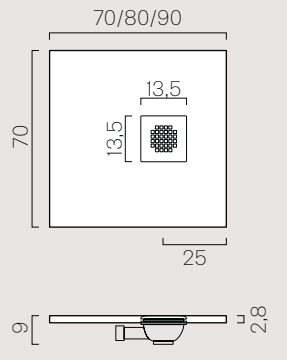

Le immagini presenti in questo volume sono puramente indicative ed i prodotti possono subire lievi variazioni anche senza nessun preavviso, le tonalità di colore sono suscettibili di variazioni. I riferimenti colore mostrati, per effetto del tempo o del supporto di stampa, potrebbero non coincidere con le tonalità di colore dei prodotti ceramici finiti /

The images in this volume are purely indicative and the products may undergo slight variations even without any prior notice. The color tones are susceptible to variations. The color references shown, due to time or printing reasons, may not correspond with the color tones of the finished ceramic products /

Die in diesem Band enthaltenen Bilder dienen allein Veranschaulichungszwecken. Die Produkte ebenso wie die Farbtöne können auch unangekündigt leichten Veränderungen unterliegen. Die im Katalog aufgeführten Farben können abhängig vom Druckverfahren und dem Druckmedium von den Farbtönen der fertigen Keramikprodukte abweichen

Art Direction, Graphic Design, Layout
Studio CCRZ

Images
Ciapetti Lab
Riccardo Borgenni
Studio 9010

Styling
Monti Studio

Coordination
GSILab

Printed by
Intese Grafiche

Thanks to
Agape, AYTM, Bloc Studio, Celeido, Castellani & Smith, cc-tapis, Ceadesign, Cristina Rubinetterie, Desalto, Dornbracht, Edoné Design, Emanuel Gargano, Fioroni, Flos, Fratelli Fantini, Frity Hansen, Jean-François D'Or, Kasthall, Il giardino di Legno, Iris Ceramica, Living Divani, Luceplan, Maison Vervloet, Mamoli, MM Lampadari, Molteni&C, Moroso, Muuto, Nanban, Nodus, Paolo Giordano per I+I collection, Rubinetterie Ritmonio, Rubinetterie Treemme, Rugstar, Scarazzini, SP01 Design, Studio C, Vibia, Vitra, Zanotta

Printed
04/2021



Italian Made

GSI

S.p.a. Strada Provinciale 150, km 3,125
01035 Gallese (VT), Italia
T +39 07614911
F +39 0761496111
www.gsiceramica.it