

Ceramica  
VOGUE

Products & Solutions



Ceramica  
VOGUE

5 / **Produzione** Producción Производство 生產

13 / **Prodotti** Productos Продукция 產品

19 / **VOGUE System**

Interni

Trasparenze

Flooring R10 B (A+B)

Grip R11 C (A+B+C)

103 / **VOGUE Link**

Interni Mix

Trasparenze Mix

Flooring Mix R10 B (A+B)

Grip Mix R11 C (A+B+C)

115 / **VOGUE Floor**

Interni40

Flooring40 R10

Grip40 B (A+B)

127 / **VOGUE Pool**

Bump C (A+B+C) V6

Special Pool

143 / **Referenze** Referencias Проекты 參考

193 / **Schede Tecniche** Fichas técnicas Технические карты 技術圖表



# **Piastrelle in grès smaltato in pasta bianca, ingelivo**

**Cerámicas en gres esmaltado en pasta blanca anti hielo**

**Морозоустойчивая плитка из керамического гранита на основе белой глины**

**白色耐霜凍的玻璃釉炻質磚**



**Produzione**

Producción

Производство

生産





## Ceramica Vogue, l'azienda

Dal 1978, anno in cui abbiamo iniziato la nostra attività, Ceramica Vogue ha messo le proprie competenze al servizio di progettisti e decoratori d'interni, affermandosi come azienda leader nella produzione di piastrelle in grès smaltato in pasta bianca, ingelivo, per pavimenti e rivestimenti. Le elevate prestazioni tecniche e l'attenzione destinata alla ricerca estetica caratterizzano i prodotti a marchio Ceramica Vogue dando vita a un'ampia gamma di collezioni pensate per arredare con soluzioni innovative ambienti interni ed esterni. Un vasto catalogo di tinte unite declinate in molteplici formati e finiture, tutte corredate da pezzi speciali, ha fatto sì che la nostra immagine si affermasse con successo sui mercati europei e internazionali: parte della nostra produzione viene esportato all'estero, dove Ceramica Vogue è presente con uffici propri (Russia e Cina) e con agenti e distributori. Attualmente Ceramica Vogue, azienda del gruppo Altaeco S.p.A., produce annualmente 2.500.000 m<sup>2</sup> di piastrelle, dispone di magazzini coperti per oltre 20.000 m<sup>2</sup> e occupa circa 180 dipendenti.

## Ceramica Vogue, la empresa

Desde 1978, año en que empezó nuestra actividad, Ceramica Vogue ha puesto sus competencias al servicio de diseñadores y decoradores de interiores, afirmándose como empresa líder en la producción de cerámicas en grés esmaltado en pasta blanca, anti hielo, para suelos y revestimientos. Las elevadas prestaciones técnicas y la atención destinada a la búsqueda estética caracterizan los productos marca Ceramica Vogue, dando vida a un dilatado abanico de colecciones creadas para decorar los interiores y exteriores con soluciones innovadoras. Un amplio catálogo de colores lisos, desarrollados en múltiples formatos y acabados, acompañados por piezas especiales, ha permitido afianzar la imagen de la empresa en los mercados europeos e internacionales: parte de nuestra producción se exporta al extranjero, donde Ceramica Vogue está presente con sus oficinas (Rusia y China) y con agentes y distribuidores. En la actualidad, Ceramica Vogue, empresa del grupo Altaeco S.p.A., produce anualmente 2.500.000 m<sup>2</sup> de revestimientos, dispone de almacenes cubiertos que ocupan más de 20.000 m<sup>2</sup> y cuenta con una plantilla de 180 personas aproximadamente.

## Ceramica Vogue, о компании

С 1978 года - даты основания нашей компании, Ceramica Vogue предлагает свои услуги проектировщикам и отделочникам, закрепив себя на лидирующей позиции в производстве плитки из морозоустойчивого эмалированного керамогранита из белой глины для стен и полов. Высокие технические показатели, внимание к эстетическим запросам характеризуют продукцию Ceramica Vogue. Ceramica Vogue создала огромную гамму коллекций с инновационными решениями для проектировщиков и декораторов. Широкая гамма одноцветной плитки, представленная многочисленными форматами и разными типами поверхности, дополненная специальными элементами, – всё это стало сильной стороной компании, выделяя её на европейском и мировом рынках. Часть нашей продукции экспортируется. Ceramica Vogue имеет свои представительства в России и Китае и агентов и дистрибьюторов в других странах. Сегодня Ceramica Vogue входит в состав группы Altaeco s.p.a. и производит ежегодно 2 500 000 кв.м. плитки, имеет закрытые склады площадью свыше 20 000 кв.м. и 180 человек в штате.

## Ceramica Vogue, 陶瓷, 公司簡介

從1978起，我們開始了公司的各項事務，陶瓷Vogue 將自己的側重點放在為室內設計師與裝飾師提供服務上，從而將品牌提升為耐霜凍的玻璃釉陶瓷磚與炻質磚的領導者。高技術性能和對設計專注可以從任何貼有陶瓷Vogue商標的產品上體現出來，運用創新的解決方案創造出各種不同的產品系列應用於室內和室外裝飾。豐富的產品目錄展示出多尺寸和表面的素色產品，所有顏色都擁有特殊配件，我們的形象成功的滲透到歐洲和國際市場：部分我們的產品被出口到兩個Vogue擁有自己獨立辦公室的地方（俄羅斯和中國）在這些地方我們通過代理商和經銷商進行銷售。現在陶瓷Vogue, Altaeco S.p.A.工業集團旗下公司，每年生產2,500,000 平米瓷磚，僱傭180名職員。

## Made in italy

Ceramica VOGUE è un'azienda italiana che inventa, progetta e realizza ceramiche di altissima qualità, apprezzate in tutto il mondo e capaci di soddisfare anche il cliente più esigente. Scegliere uno dei nostri prodotti significa optare per l'innovazione e per processi industriali che si basano su tecnologie all'avanguardia. Ogni nostra realizzazione è un equilibrato mix di materie prime eccellenti e tecniche produttive innovative, capaci di garantire la piacevolezza del risultato finale nel rispetto dell'ambiente che ci circonda. Siamo una realtà convinta che l'attenzione per l'estetica e l'utilizzo consapevole delle tecniche più evolute, siano alla base della creazione di prodotti di qualità. Tradizione italiana, cultura del lavoro, impegno nella ricerca e innovazione, cura dell'estetica: sono questi i fattori che ci differenziano e che fanno della Ceramica VOGUE un leader riconosciuto a livello internazionale nella produzione di piastrelle in grès smaltato in pasta bianca, ingelivo, per pavimenti e rivestimenti.

## Made in Italy

Ceramica VOGUE es una empresa italiana que inventa, diseña y realiza cerámicas de alta calidad, apreciadas en todo el mundo y capaces de satisfacer también al cliente más exigente. Escoger uno de nuestros productos, significa optar por la innovación y por procesos industriales que se basan sobre tecnologías de vanguardia. Cada una de nuestras realizaciones es una mezcla equilibrada de materias primas excelentes y técnicas de producción innovadoras, capaces de garantizar un resultado final agradable respetando el medio ambiente que nos rodea. Estamos convencidos de que la atención por la estética y el uso conciente de las técnicas más avanzadas, constituyen la base para la creación de productos de calidad. Tradición italiana, cultura del trabajo, compromiso con la investigación y la innovación, atención a la estética: estos son los factores que nos distinguen y que hacen de Ceramica VOGUE un líder reconocido a nivel internacional en la producción de cerámicas en gres esmaltado en pasta blanca, anti hielo, para suelos y revestimientos.

## Made in Italy

Ceramica VOGUE – это итальянская фирма, которая изобретает, проектирует и производит высококачественную керамику. Плитку Vogue ценят во всём мире, и она удовлетворяет даже самых требовательных клиентов. Выбрать наши изделия, значит выбрать инновацию и промышленные процессы, основанные на передовых технологиях. Каждый из наших продуктов – это сбалансированное смешение высококачественного сырья и инновационных технологий производства. Соответственно, плитка Vogue гарантирует удовлетворение от качества результата, полученного полностью экологическим способом. Мы считаем, что качественный продукт – это сочетание вкуса и сознательного использования более продвинутых промышленных процессов. Итальянские традиции, внимание к деталям, постоянный вклад в исследования и инновации, забота об эстетической красоте – все эти факторы выделяют Ceramica Vogue и делают ее международным лидером в производстве плитки из морозоустойчивого эмалированного керамогранита из белой глины для стен и полов.

## Made in Italy

陶瓷Vogue是一家創造、設計和生產高品質陶瓷的意大利公司，公司的產品享譽全球並可滿足最苛刻的客戶要求。選擇我們的產品就意味著選擇以尖端科技為基礎的創新的工業生產方法。我們的每一個產品都是精良的原料與創新生產技術的完美結合，在尊重我們生存的空間環境的基礎上能達到令人滿意的最終效果。我們的公司相信對美學和對最先進技術已知用途的重視是製造優秀產品的基本原則。意大利傳統，職業道德，恪守承諾和創新，重視設計：這些因素讓陶瓷VOGUE不同於其他品牌，被公認為製造玻璃釉陶瓷磚與炻質磚的國際領導者。



## L'impegno per l'edilizia sostenibile

Ceramica Vogue esplicita il proprio impegno ecologico aderendo al Green Building Council Italia (GBC Italia), associazione no profit finalizzata a promuovere e a diffondere la cultura di un'edilizia sostenibile. La nostra azienda condivide filosofia e obiettivi del "costruire verde": la progressiva trasformazione del mercato verso modalità di costruzione responsabili ed ecocompatibili, la sensibilizzazione delle istituzioni e dell'opinione pubblica circa la necessità di evitare un impatto invasivo dell'edilizia sull'ambiente e la divulgazione agli operatori del settore di linee guida per una progettazione capace di influire positivamente sulla qualità della vita dei cittadini. GBC Italia è promotrice del sistema di certificazione indipendente e diffuso a livello globale LEED® (Leadership in Energy and Environmental Design), che garantisce le prestazioni di edifici costruiti secondo i parametri del risparmio idrico ed energetico, della riduzione delle emissioni di CO<sub>2</sub>, del miglioramento della qualità ecologica degli interni e di una scelta responsabile del sito, dei materiali e delle risorse impiegate.

## El empeño por una construcción sostenible

Ceramica Vogue expresa su empeño ecológico adhiriendo al Green Building Council Italia (GBC Italia), asociación sin fines de lucro finalizada a promover y difundir la cultura de la construcción sostenible. Nuestra empresa comparte la filosofía y objetivos de la "construcción ecológica": la transformación gradual del mercado hacia formas de construcción responsables y ecocompatibles, la sensibilidad de las instituciones y de la opinión pública acerca de la necesidad de evitar un impacto invasivo de la construcción sobre el medio ambiente y la divulgación a los operadores del sector de directrices para un diseño que influya positivamente sobre la calidad de vida de los ciudadanos. GBC Italia es promotora del sistema de certificación independiente y difundido a nivel global LEED® (Leadership in Energy and Environmental Design), que garantiza los rendimientos de los edificios construidos de acuerdo con los parámetros de ahorro hídrico y energético, de la reducción de las emisiones de CO<sub>2</sub>, del mejoramiento de la calidad ecológica de los interiores y de una elección responsable del lugar, materiales y recursos utilizados.

## Обязательство к экологическому строительству

Ceramica Vogue осуществляет свое обязательство к экологии и является членом ассоциации Green Building Council Italia. Ассоциация Green Building Council Italia не коммерческая, продвигает и распространяет философию основы экологического строительства. Мы поддерживаем эту философию и цели «зеленого строительства»: трансформация рынка в сторону строительства более продуманным и экологическим способом, привлечение внимания учреждений и общественного мнения как избежать влияния строительства на окружающую среду, как разрабатывать проекты зданий, которые улучшают качество жизни человека. Ассоциация продвигает независимую сертификацию LEED® (Leadership in Energy and Environmental Design), которая гарантирует строительство и эксплуатационные характеристики зданий, основываясь на экономии воды и электричества, уменьшении выброса CO<sub>2</sub> в атмосферу, гарантии на экологические качества внутри помещения, выбор места строительства, материалов и ресурсов использованных для строительства.

## 決心從事可持續建築

陶瓷Vogue以意大利綠色建築學會這個有計劃的發揚和宣傳綠色建築文化的非盈利機構成員的身份 (GBC Italia) 表明自身的綠色本性。我們的公司分享傳播“綠色建築”的理念和宗旨：隨著市場逐步對負責任的與生態兼容的施工方式的認可，提高體系認知度與公輿論監督機制從而避免對環境有負面影響的建築物產生以及在各部門之間傳播對生活質量有積極影響的宣傳准則。GBC 意大利綠色建築協會隸屬於全球獨立的認證體系 LEED® (能源與環境設計領導者)該體系提供在建造中節省水資源與能源的建築物性能的認證，減少CO<sub>2</sub>的排放量，提升了室內設計的綠色質量並在選擇地址，材料以及對資源的使用等方面充分負責。

## POLITICA A CHILOMETRO ZERO

**km0**

Utilizzo di materie prime esclusivamente nazionali a impronta ecologica controllata  
 Uso de materias primas exclusivamente italianas con huella ecológica controlada  
 Использование исключительно национального сырьевого материала с ограниченными экологическими последствиями  
 在可控足跡的約束下使用專門的國有原材料



## RIUTILIZZO DELL'ACQUA

Riutilizzo al 100% delle acque reflue della produzione  
 Reducción del 42% del fabbisogno idrico dello stabilimento  
 Reutilización del 100% de las aguas residuales de producción  
 Reducción del 42% de la demanda hídrica de la planta  
 Повторное использование 100% сточных вод собственного производства  
 Снижение на 42% водных потребностей завода  
 生產中100%使用再循環水  
 減少42%的工厂所需水



## RICICLO DEL VETRO

**40%**

Riutilizzo degli scarti del processo di riciclo del vetro nell'impasto del gres porcellanato  
 Reutilización de los residuos de proceso de reciclaje del vidrio en la masa del gres porcelánico  
 Повторное использование отходов процесса переработки стекла в составе основы керамического гранита  
 主體陶瓷原料都是經過對玻璃回收循環步驟的反復使用而得來

## TAGLIO DELLE EMISSIONI

**-10%**

Minimo impatto nella produzione di gas serra. Emissioni ridotte di dieci volte rispetto al passato  
 Repercusión mínima en la producción de gas invernadero. Emisiones diez veces menores respecto del pasado  
 Сведенное к минимуму производство парникового газа. Эмиссии – в 10 раз меньше по сравнению с предыдущими  
 在生產過程中經過數十次的減排，將溫室氣體的排放減至最小。

## RECUPERO SCARTI CRUDI

**100%**

Riciclo degli scarti crudi, reintegrati al 100% nella filiera di produzione  
 Reciclaje de residuos crudos, reintegrados al 100% en la cadena de producción  
 Повторный ввод 100% необработанного брака в производственный ряд  
 在流水線上100% 循環使用未燒廢料。

## RECUPERO ENERGETICO

**-40%**

Recupero del calore del ciclo di produzione. Riduzione del 40% dell'uso di combustibili fossili  
 Recuperación de calor del ciclo de producción. Reducción del 40% del uso de combustibles fósiles  
 Повторное использование тепла производственного цикла.  
 Снижение на 40% использования ископаемого топлива  
 通過生產循環恢復高溫。減少使用40%的礦物原料。



## RECUPERO SCARTI COTTI

Riciclo degli scarti cotti, riutilizzati al 100% come materiale inerte per l'edilizia  
 Reciclaje de los residuos cocidos, reutilizados al 100% como áridos para la construcción  
 Повторное использование 100% обожженного сырья как инертного материала для строительства  
 循環利用燃油廢料，在生產過程中100%的惰性材料被再利用

## IMBALLAGGI SOSTENIBILI

**100%**

Imballaggi riciclabili al 100%. Pallet di giacenza e trasporto in conformità con lo standard IPPC FAO ISPM 15  
 Embalajes completamente reciclables. Paleta de almacenamiento y transporte conforme a la norma IPPC FAO ISPM 15  
 Упаковки на 100% пригодны для повторного использования. Поддоны для хранения и транспорта соответствуют стандарту IPPC ISPM 15  
 100%可循環包裝。儲存的貨盤和運輸工具都符合PPC FAO ISPM 15標準



## Ecosostenibilità della produzione

Ceramica Vogue dedica la massima attenzione all'impatto ambientale della propria produzione, impegnandosi nella realizzazione di ceramiche che coniughino gli elevati standard qualitativi con la tutela della natura e con il rispetto dei criteri di uno sviluppo etico e sostenibile. L'intero ciclo di lavorazione dei prodotti è pensato in funzione dell'ottimizzazione delle risorse e della riduzione delle emissioni di anidride carbonica, grazie al riutilizzo delle materie prime e agli investimenti atti a garantire il recupero energetico. Adattando le proprie tecnologie e i propri impianti di produzione, Ceramica Vogue si è specializzata nel processo di riciclo del vetro e ad oggi utilizza nell'impasto del proprio grès smaltato in pasta bianca, ingelivo, fino al 40% di una miscela di vetro e feldspato: ciò che prima era rifiuto diventa catalizzatore delle materie prime, migliorando le caratteristiche tecniche ed estetiche del prodotto finale. Il materiale di riciclo proviene da giacimenti situati in prossimità degli stabilimenti di lavorazione, in conformità con la politica a chilometro zero scelta dall'azienda.

## Ecosostenibilidad de la producción

Ceramica Vogue pone la máxima atención en el impacto que su producción tiene sobre el medio ambiente, y realiza cerámicas que unen altos estándares de calidad con la protección de la naturaleza y con el respeto de criterios de desarrollo ético y sostenible. El entero ciclo de producción de los productos se ha pensado en función de la optimización de los recursos y la reducción de las emisiones de anhídrido carbónico, gracias a la reutilización de las materias primas y a las inversiones destinadas a garantizar la recuperación energética. Adaptando las tecnologías y las instalaciones de producción propias, Ceramica Vogue se ha especializado en el proceso de reciclaje del cristal y, hasta hoy, utiliza en la composición del gres esmaltado en pasta blanca, anti hielo, hasta un 40% de una mezcla de cristal y feldespato: lo que antes eran desechos se convierten en catalizadores de las materias primas, mejorando las características técnicas y estéticas del producto final. El material de reciclaje procede de yacimientos situados cerca de las plantas de producción, de conformidad con la política de kilómetro cero de la empresa.

## Экологическое производство

Ceramica Vogue уделяет самое пристальное внимание на окружающую среду: высокие стандарты качества сочетаются с охраной природы и с принципами этического и устойчивого развития. Весь процесс производства направлен на оптимизацию ресурсов и на снижение выбросов углекислого газа, благодаря повторному использованию сырья и инвестициям, гарантирующим повторное использование энергии. После модификации своего производственного оборудования и технологий Ceramica Vogue специализируется в переработке стекла и на сегодняшний день использует до 40% смеси из стекла и полевого шпата в производстве морозостойчивого эмалированного керамогранита из белой глины: то, что раньше было отходами, стало катализатором природных материалов, улучшив таким образом технические и эстетические характеристики конечного продукта. Материалы отходов берутся из карьеров, находящихся недалеко от цехов фабрики, основываясь на выбранной нами политике «нулевого километра».

## 生態可持續生產

陶瓷Vogue 投入最大的精力關注在生產過程中對環境可能造成的影響，並致力於生產出具有最好品質標準的產品的同時本著對道德和可持續發展準則的尊重兼顧對環境的保護。整個產品生產過程以充分利用資源並減少二化的排放為宗旨，通過對原材料的再使用以及對能確保能量回收系統的投資。通過改變自身生產與技術系統陶瓷Vogue 具有專業的玻璃回收技術，而今使用混合玻璃以及長石為自身玻璃釉陶瓷磚與炆質磚的主體已成為該產品所特有的美學特點。這些可回收的材料來源於工廠附近的地方物料，與工廠“零-英里”政策相吻合。

## VOGUE System

Interni

Trasparenze

Flooring R10 B (A+B)

Grip R11 C (A+B+C)

## VOGUE Link

Interni Mix

Trasparenze Mix

Flooring Mix R10 B (A+B)

Grip Mix R11 C (A+B+C)

## VOGUE Floor

Interni40

Flooring40 R10

Grip40 B (A+B)

## VOGUE Pool

Bump C (A+B+C) V6

Special Pool

# Prodotti

Productos  
Продукция  
產品

## VOGUE System

### Grip R11 C (A+B+C)

**IG** Finitura antiscivolo satinata per superfici bagnate, caratterizzata da aderenza elevata. Disponibile in 14 tonalità opache e in 3 formati. Acabado antideslizante satinado para superficies mojadas, caracterizado por una elevada adherencia. Disponible en 14 colores mates y 3 formatos. Противоскользящая сатиновая отделка для мокрых поверхностей с высоким сцеплением. В 14 матовых цветах и в 3 форматах. 亞光以及防滑表面針對於潮濕區域，添加牢固的手柄。擁有14種不透明顏色以及3種尺寸。

### Flooring R10 B (A+B)

**RF** Finitura antiscivolo satinata per superfici umide/asciutte, caratterizzata da buona aderenza. Disponibile in 14 tonalità opache e in 4 formati modulari. Acabado antideslizante satinado para superficies húmedas/secas, caracterizado por una buena adherencia. Disponible en 14 colores y 4 formatos modulares. Противоскользящая сатиновая отделка для влажных/сухих поверхностей с хорошим сцеплением. В 14 матовых цветах и в 4 модульных форматах. 亞光和防滑表面針對潮濕/乾燥區域，增加手柄。擁有14種不透明顏色以及4種尺寸。

### Trasparenze

**TR** Finitura lucida, disponibile in 30 tonalità brillanti e in più formati modulari corredati di tozzetti e pezzi speciali. Acabado brillante, disponible en 30 colores brillantes y en varios formatos modulares acompañados por piezas pequeñas y piezas especiales. Глянцевая отделка в 30 блестящих цветах и в разных модульных форматах дополняется специальными элементами. 光亮表面，擁有30種鮮艷的色彩以及多種尺寸，另有嵌入部件以及特殊配件。

### Interni

**IN** Finitura satinata, disponibile in 38 tonalità cromatiche e in più formati modulari corredati di tozzetti e pezzi speciali. Acabado satinado, disponible en 38 colores y en varios formatos modulares acompañados por piezas pequeñas y piezas especiales. Сатиновая отделка в 38 цветах и в разных модульных форматах дополняется специальными элементами. 亞光表面，擁有38種飽艷顏色以及多種尺寸，另有嵌入部件以及特殊配件。

## VOGUE Link

### Interni Mix/Trasparenze Mix

**MIN/MTR** Finitura satinata, disponibile in 21 tonalità formato 5x5 montato su fibra/Finitura lucida, disponibile in 17 tonalità brillanti formato 5x5 montato su fibra. Acabado satinado, disponible en 21 colores formato 5x5 montado sobre fibra/Acabado brillante, disponible en 17 tonos brillantes formato 5x5 montado sobre fibra. Матовая поверхность, 21 оттенок, формат 5x5 на сетке из стекловолокна/Глянцевая поверхность, 17 блестящих оттенков, формат 5x5 на сетке из стекловолокна. 亞光飾面，尺寸為5x5，有21種色調，固定在纖維上/拋光飾面，尺寸為5x5，有17種明亮的色調，固定在纖維上。

### Flooring Mix R10 B (A+B)/Grip Mix R11 C (A+B+C)

**M RF/M IG** Finitura antiscivolo satinata per superfici umide/asciutte, in 6 tonalità/ Finitura antiscivolo satinata per superfici bagnate, in 6 tonalità formato 5x5 montato su fibra di vetro. Acabado antideslizante satinado para superficies húmedas/secas, en 6 colores/ Acabado antideslizante satinado para superficies mojadas, en 6 colores formato 5x5 montado sobre fibra de vidrio. Матовая противоскользящая поверхность для отделки мокрых и сухих зон, 6 оттенков/ Матовая противоскользящая поверхность для отделки мокрых зон, 6 оттенков, формат 5x5 на сетке из стекловолокна. 針對潮濕/乾燥表面的防滑亞光飾面，有6種色調/針對潮濕表面的防滑亞光飾面，尺寸為5x5，有6種色調，固定在玻璃纖維上。

## VOGUE Floor

### Interni40/Flooring40 R10

**IN/RF** Finitura satinata, in 14 tonalità cromatiche nel formato 40x40/Finitura antiscivolo satinata per superfici asciutte, in 16 tonalità nel formato 40x40. Acabado satinado, en 14 tonos cromáticos en el formato 40x40/ Acabado antideslizante satinado para superficies secas, en 16 tonos en el formato 40x40. Матовая поверхность, 14 цветовых оттенков, формат 40x40/Противоскользящая матовая поверхность для отделки сухих зон, 16 оттенков, формат 40x40. 亞光飾面，尺寸為40x40，有14種不同的色調/用於乾燥表面的防滑亞光飾面，尺寸為40x40，有16種色調。

### Grip40 B (A+B)

**IG** Finitura antiscivolo satinata per superfici umide/asciutte, caratterizzata da buona aderenza, disponibile in 6 tonalità nel formato 40x40. Acabado antideslizante satinado para superficies húmedas/secas, caracterizado por una buena adherencia, disponible en 6 colores formato 40x40. Матовая противоскользящая плитка для отделки мокрых и сухих зон, хорошая степень сцепления, 6 оттенков, формат 40x40. 針對潮濕/乾燥表面的防滑亞光飾面，具有附著力強的特性，尺寸為40x40，有6種色調。

## VOGUE Pool

### Bump C (A+B+C) V6

**BP** Finitura antiscivolo strutturata, disponibile in 8 tonalità nel formato 10x20. Acabado antideslizante estructurado, disponible en 8 tonos en el formato 10x20. Противоскользящая структурированная поверхность, 8 оттенков, формат 10x20. 防滑紋飾面，尺寸為10x20，有8種色調。

Ideato da Ceramica Vogue per soddisfare ogni esigenza di progettazione, il Vogue System si propone come soluzione d'arredo per spazi interni ed esterni ad uso pubblico e privato. Il sistema si articola in quattro finiture atte a rispondere a differenti necessità tecniche, declinate nelle medesime tonalità di un'ampia gamma cromatica e disponibili in più formati modulari. Colori e formati complementari consentono di realizzare numerose combinazioni e accostamenti, moltiplicando le possibilità d'impiego del Vogue System.

Creado por Ceramica Vogue para satisfacer las demandas de diseño, el Vogue System se propone como una solución decorativa para interiores y exteriores para uso público y privado. El sistema consta de cuatro acabados que responden a distintas necesidades técnicas, en los tonos de una dilatada gama cromática y disponibles en varios formatos modulares. Con los colores y formatos complementarios se realizan numerosas combinaciones y composiciones, multiplicando las posibilidades de utilización de Vogue System.

Vogue system – это комплект для проектирования общественного или частного интерьера и экстерьера. Система состоит из четырёх отделок для различных технических потребностей, в широкой цветовой гамме и в разных модульных форматах. Разнообразие цветов и форматов позволяет создавать комбинации и сочетания, увеличивая возможности использования Vogue System.

陶瓷 Vogue 的設計可滿足所有設計需求, Vogue 系統為室內與室外, 公共與私人區域提供裝飾解決方案。該體系包括四種不同的表面可響應不同的技術需求, 所有表面都擁有同樣廣泛的顏色以及一系列標準的尺寸。補充的顏色與尺寸可以搭配使用創造出不同組合與圖案, 使用 Vogue 系統可延伸出無限可能。

## VOGUE Link [pag. 103]

La collezione Vogue Link raggruppa prodotti che sono derivati dal Vogue System e con esso si integrano per formati e finiture. Pensata per soluzioni decorative sia in ambito residenziale che pubblico, ideale per pavimenti e rivestimenti in base alle caratteristiche della superficie utilizzata. Le molteplici proposte cromatiche offrono soluzioni progettuali in grado di rendere unico ogni ambiente.

La colección Vogue Link reúne productos que derivan del Vogue System y sus formatos y acabados se integran en el mismo. Pensado para soluciones decorativas tanto en ámbito residencial como público, ideal para suelos y revestimientos en base a las características de la superficie utilizada. Las múltiples propuestas cromáticas ofrecen soluciones de diseño capaces de dar unicidad a un espacio.

В серию Vogue Link входит сопутствующая продукция, сочетающаяся по форматам и видам поверхностей с Vogue System. Данная линия разработана для декоративной отделки как частных, так и общественных зон, она идеальна для применения в качестве напольных покрытий и облицовки в зависимости от используемого вида плитки. Цветовое многообразие позволяет создавать различные варианты отделки, придающие уникальный облик любому помещению.

Vogue Link系列將衍生于Vogue System的產品組合在一起, 包括不同的尺寸和飾面。這是一種即適用於住宅也應用於公共場所的裝飾解決方案, 可根據地板和牆面的不同使用特性選擇理想的飾面。通過多種色彩的產品所提供的设计解決方案, 可使每一種環境都独具特色。

## VOGUE Floor [pag. 115]

Le serie del Vogue Floor sono appositamente pensate per un uso a pavimento. Ricerca estetica, elevate prestazioni tecniche e un'ampia scelta cromatica permettono di ricoprire anche grandi superfici in spazi pubblici o privati.

Las series Vogue Floor han sido estudiadas expresamente para su uso como pavimento. Por el estudio estético, las altas prestaciones técnicas y una dilatada gama de colores pueden revestir incluso superficies grandes en espacios públicos o privados.

Серии Vogue Floor специально разработаны для напольного покрытия. Благодаря стилю, высоким техническим качествам и широкому выбору цветов они подходят, как к частному интерьеру, так и к большим общественным пространствам.

Vogue 地面系列專門為地磚設計。精緻的審美, 提供高性能以及廣泛的顏色, 可以覆蓋各種公共以及私人地區甚至大面積區域。

## VOGUE Pool [pag. 127]

La collezione Vogue Pool offre prodotti e pezzi speciali appositamente studiati per la progettazione e realizzazione di piscine.

La colección Vogue Pool ofrece productos y piezas especiales expresamente estudiados para el diseño y realización de piscinas.











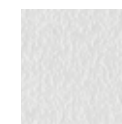



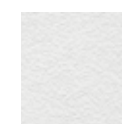



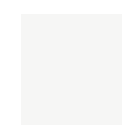









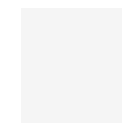
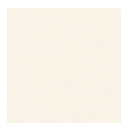





В серию Vogue Pool входят изделия, специально разработанные для отделки бассейнов.

Vogue Pool系列是为游泳池的设计和施工而专门设计的产品和特殊配件。

VOGUE System

Grès smaltato in pasta bianca, ingelivo Gres esmaltado en pasta blanca anti hielo

















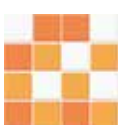

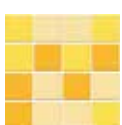
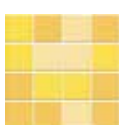



морозоустойчивый эмалированный керамогранит из белой глины 白色耐霜凍的玻璃釉陶瓷磚

<p><b>IG</b> <b>Grip R11 C (A+B+C)</b> Superficie antiscivolo satinata Superficie antideslizante satinada Противоскользящая сатирированная поверхность 亞光施釉防滑表面</p>	<p>pavimento pavimento пол 地磚</p>	<p>5x5 cm 10x10 cm 20x20 cm Pezzi Speciali</p>	 IG ghiaccio	 IG seta								 IG rosso	 IG mandarino	 IG giallo					
<p><b>RF</b> <b>Flooring R10 B (A+B)</b> Superficie antiscivolo satinata Superficie antideslizante satinada Противоскользящая сатирированная поверхность 亞光施釉防滑表面</p>	<p>pavimento pavimento пол 地磚</p>	<p>5x5 cm 10x10 cm 20x20 cm 20x40 cm</p>	 RF ghiaccio	 RF seta								 RF rosso	 RF mandarino	 RF giallo					
<p><b>TR</b> <b>Trasprenze</b> Superficie lucida Superficie brillante Глянцевая поверхность 亮光表面</p>	<p>rivestimento revestimiento облицовка 牆磚</p>	<p>5x5 cm 5x20 cm 5x40 cm 10x10 cm 10x20 cm 20x20 cm 20x40 cm Bisello 10x10 cm Bisello 10x20 cm Pezzi Speciali</p>	 TR ghiaccio	 TR seta	 TR beige			 TR rosa	 TR albicocca	 TR papaya	 TR caffè	 TR rosso	 TR corallo	 TR mandarino	 TR giallo				
<p><b>IN</b> <b>Interni</b> Superficie satinata Superficie satinada Сатирированная поверхность 亞光施釉表面</p>	<p>pavimento e rivestimento Pavimento y revestimiento Пол и облицовка 牆地兩用磚</p>	<p>5x5 cm 5x20 cm 5x40 cm 10x10 cm 10x20 cm 20x20 cm 20x40 cm Bisello 10x10 cm Bisello 10x20 cm Pezzi Speciali</p>	 IN ghiaccio	 IN latte	 IN seta	 IN beige	 IN nocciola	 IN tortora	 IN rosa	 IN albicocca	 IN papaya	 IN arancio	 IN caffè	 IN bordeaux	 IN rosso	 IN corallo	 IN mandarino	 IN girasole	 IN giallo

VOGUE Link

Grès smaltato in pasta bianca, ingelivo Gres esmaltado en pasta blanca anti hielo

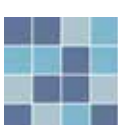
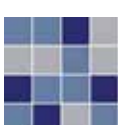
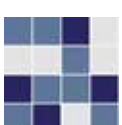

















морозоустойчивый эмалированный керамогранит из белой глины 白色耐霜凍的玻璃釉陶瓷磚

<p><b>M IN/M TR</b> <b>IN Mix/TR Mix</b> Superficie satinata/lucida Superficie satinada/brillante Глянцевая/противоскользящая поверхность 亞光施釉/亮光表面</p>	<p>Pavimento e rivestimento Pavimento y revestimiento Пол и облицовка 牆地兩用磚</p>	<p>(5x5 cm) 30x30 cm montato su fibra di vetro</p>	 M IN 01	 M IN 02	 M IN 03	 M TR 01	 M IN 04	 M IN 05	 M IN 06	 M TR 02	 M IN 07	 M TR 03	 M IN 08	 M TR 04	 M IN 09	 M TR 05	 M IN 10	 M TR 06	 M IN 11
<p><b>M RF/M IG</b> <b>RF Mix/IG Mix</b> Superficie antiscivolo satinata Superficie antideslizante satinada Противоскользящая сатирированная поверхность 亞光施釉防滑表面</p>	<p>Pavimento e rivestimento Pavimento y revestimiento Пол и облицовка 牆地兩用磚</p>	<p>(5x5 cm) 30x30 cm montato su fibra di vetro</p>	 M RF 01	 M IG 01	 M RF 02	 M IG 02	 M RF 03	 M IG 03	 M RF 04	 M IG 04	 M RF 05	 M IG 05	 M RF 06	 M IG 06					

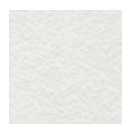
VOGUE Floor

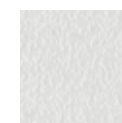
Grès smaltato in pasta bianca, ingelivo Gres esmaltado en pasta blanca anti hielo



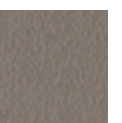





морозоустойчивый эмалированный керамогранит из белой глины 白色耐霜凍的玻璃釉陶瓷磚

<p><b>IN/RF</b> <b>Interni40/Flooring40 R10</b> Superficie antiscivolo satinata Superficie antideslizante satinada Противоскользящая сатирированная поверхность 亞光施釉防滑表面</p>	<p>pavimento pavimento пол 地磚</p>	<p>40x40 cm Battiscopa 9,5x40 cm</p>	 IN ghiaccio	 IN latte	 IN seta	 IN nocciola	 IN caffè	 IN mandarino	 IN pompelmo	 IN pistacchio	 IN oliva	 IN azzurro	 IN oltremare	 IN argento	 IN ferro	 IN nero	 RF ghiaccio	 RF seta
<p><b>IG</b> <b>Grip40 B (A+B)</b> Superficie antiscivolo satinata Superficie antideslizante satinada Противоскользящая сатирированная поверхность 亞光施釉防滑表面</p>	<p>pavimento pavimento пол 地磚</p>	<p>40x40 cm Battiscopa 9,5x40 cm</p>	 IG ghiaccio	 IG seta	 IG tortora	 IG argento	 IG grigio											

VOGUE Pool

Grès smaltato in pasta bianca, ingelivo Gres esmaltado en pasta blanca anti hielo

морозоустойчивый эмалированный керамогранит из белой глины 白色耐霜凍的玻璃釉陶瓷磚

<p><b>BP</b> <b>Bump c (A+B+C) V6</b> Superficie antiscivolo strutturata Superficie estructurada antideslizante Структурированное противоскользящее покрытие 防滑紋表面</p>	<p>pavimento pavimento пол 地磚</p>	<p>10x20 cm Special Pool</p>	 BP ghiaccio	 BP seta	 BP turchese	 BP laguna	 BP cielo	 BP cobalto	 BP grigio	 BP nero
--	---	----------------------------------	--	--	---	--	---	---	--	--

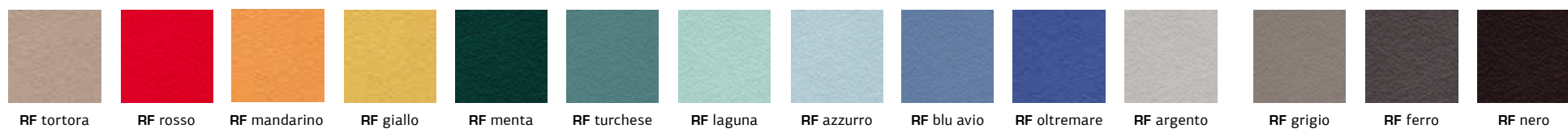
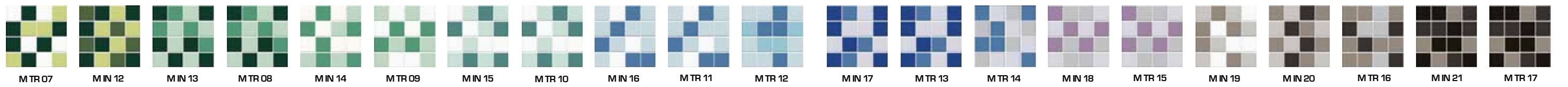
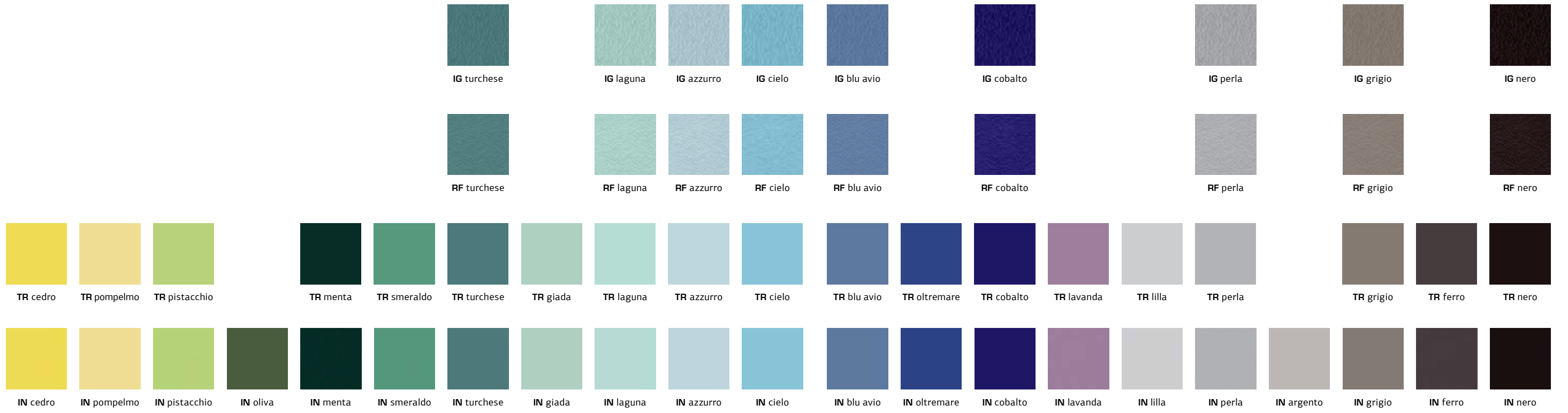



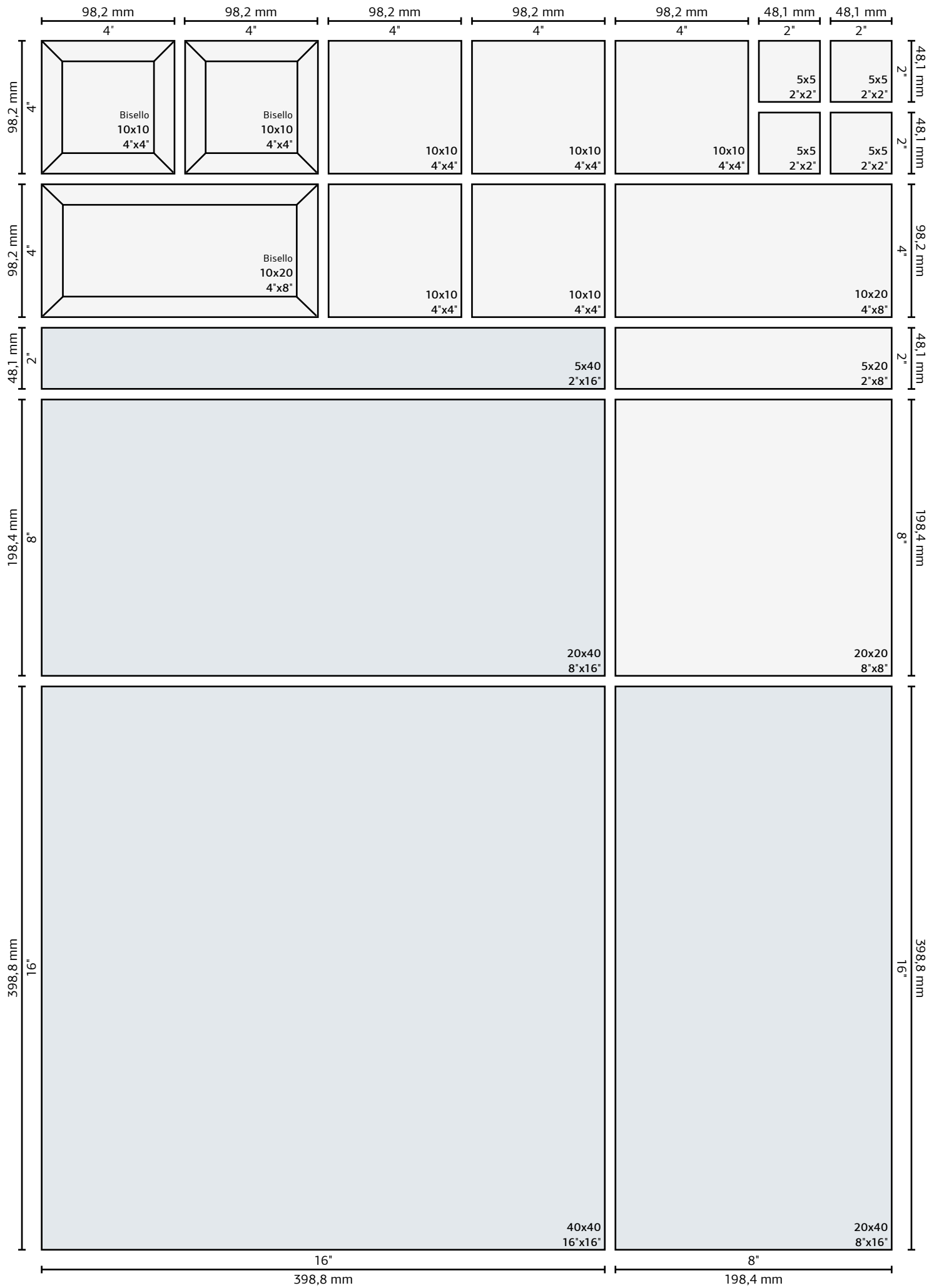



## Giunto e componibilità dei formati

Le piastrelle di tutte le collezioni Ceramica Vogue sono progettate per essere montate in combinazione tra loro: i calibri dei diversi formati sono quindi compatibili. La possibilità di combinare secondo molteplici modalità i colori, le finiture e i formati rappresenta per i progettisti una soluzione ottimale, capace di soddisfare ogni tipo di esigenza tecnica senza tuttavia sottovalutare le necessità dettate da un'attenta ricerca estetica e decorativa. Le misure riportate indicano la dimensione di fabbricazione media riferita al calibro centrale di produzione. Le tolleranze di dimensione all'interno dello stesso calibro sono stabilite dalla normativa UNI EN 14411 e si compensano normalmente fugando il materiale come da noi indicato. È possibile che siano forniti calibri inferiori o superiori a quello centrale: ne deriva che le dimensioni di fabbricazione media possono variare di conseguenza. A questo proposito, si consiglia di indicare in fase di ordinazione dei materiali i formati che si intendono utilizzare in composizione e che dovranno perciò avere calibri compatibili.

**Per ottenere un corretto risultato di posa il materiale deve essere posato con un giunto non inferiore a 2 mm (UNI 11493:2013).**

## Juntas y componibilidad de los formatos

Los revestimientos de todas las colecciones Ceramica Vogue están diseñados para ser montados combinados entre sí: los calibres de los diferentes formatos son compatibles. La posibilidad de combinar en múltiples modalidades los colores, acabados y formatos, representa para los diseñadores una solución excelente, que satisface cualquier tipo de necesidad técnica sin subestimar aquellas dictadas por un detenido estudio estético y decorativo. Las medidas indican las dimensiones de fabricación media referidas al calibre central de producción. Las tolerancias de dimensión del mismo calibre están establecidas por la normativa UNI EN 14411 y se compensan, normalmente, rejuntando el material tal como lo indicamos. Es posible que se suministren calibres inferiores o superiores de aquel central: por lo tanto, las dimensiones de fabricación media pueden variar en consecuencia. A tal fin, se aconseja indicar en el pedido de los materiales los formatos que se deben combinar y que, por dicho motivo, deben tener calibres compatibles.

**Para obtener un resultado correcto de colocación, el material debe colocarse con una junta no inferior a 2 mm (UNI 11493:2013).**

## Швы и модульность форматов

Плитки из всех коллекций Ceramica Vogue предназначены для укладки в сочетании. Размеры различных форматов совместимы. Возможности сочетания цветовой гаммы, поверхностей и форматов - это оптимальное решение для проектировщиков, чтобы удовлетворить любые технические потребности, не забывая эстетические и декоративные необходимости. Указанные размеры показывают средние фабричные измерения. Допуск размеров внутри одного калибра отрегулирован по нормативу UNI EN 14411.

Данные отклонения компенсируются при укладке с указанным фабрикой швом. Возможны отклонения калибра от центрального в сторону уменьшения или увеличения, поэтому средние фабричные размеры могут варьироваться.

По этому поводу, советуем указать при заказе материалов форматы, которые будут использоваться в сочетании и которые должны иметь совместимые калибры.

**Для получения хорошего результата укладки материал рекомендуем укладывать со швом от 2 мм (UNI 11493:2013).**

## 模塊性以及安裝

所有陶瓷Vogue的產品系列模塊的設計都考慮到可以相互搭配：不同尺寸的直徑因此相互契合。不同的尺寸，表面與顏色相互搭配所產生的無限可能，成為設計師們完美的解決方案，在不委屈設計和裝飾需求的同時可以最大限度的滿足技術要求。平均產品尺寸參照通過測量而得來的中心直徑尺寸。尺寸公差在UNI EN 14411準則制定的直徑尺寸之內如遇尺差需補產品則通常參照我們的說明操作。我們所提供的產品是有可能存在低於或高於中心直徑尺寸的情況的：因此一般來說生產尺寸或許存在差異。就這一點而言，建議在訂單中指明你想要使用的合成物的尺寸以確保所提供的直徑尺寸是兼容的。

**為了獲得正確的安裝效果材料需在安裝過程中留出不小於2mm的縫。(UNI 11493:2013).**



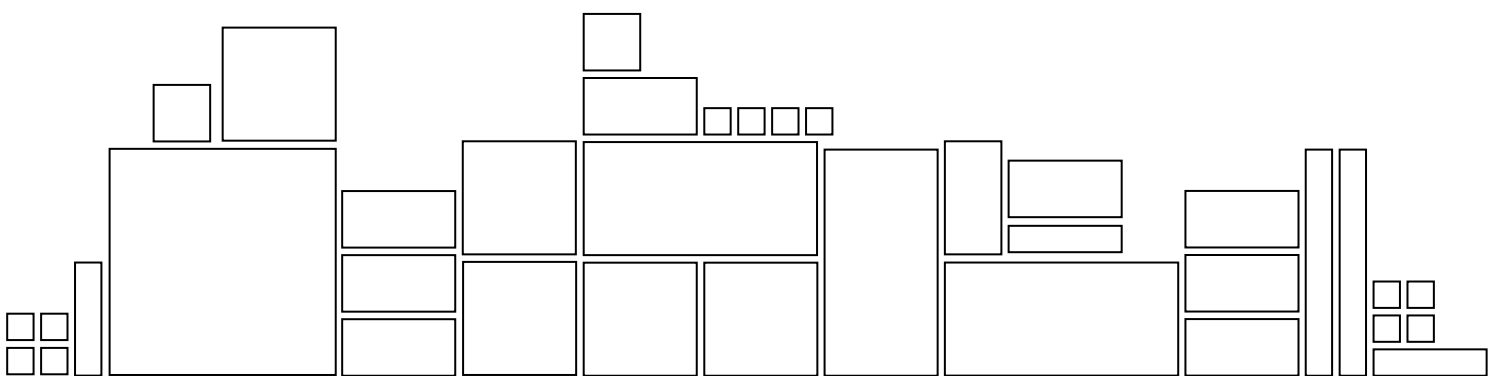

# VOGUE System

Interni

Trasparenze

Flooring R10 B (A+B)

Grip R11 C (A+B+C)

## Cos'è Vogue System

Ceramica Vogue ha ideato Vogue System, innovativo sistema ceramico pensato per ogni tipo di ambiente, in grado di soddisfare le esigenze progettuali di architetti e interior designer. Più finiture nelle medesime tonalità di un'ampia gamma cromatica declinate su 3 moduli base quadrati e 4 moduli base rettangolari, si propongono come soluzione ideale per arredare spazi residenziali e commerciali, per rivestimenti esterni e per esigenze specifiche ove sia richiesto un prodotto antiscivolo.

## Qué es Vogue System

Ceramica Vogue ha creado Vogue System, un innovador sistema cerámico adecuado para cualquier tipo de espacio, que satisface las necesidades de proyecto de arquitectos y diseñadores de interiores. Los diversos acabados en los mismos tonos de una dilatada gama de colores en 3 módulos básicos cuadrados y 4 módulos básicos rectangulares, se proponen como solución ideal para decorar espacios residenciales y comerciales, para revestimientos exteriores y para necesidades específicas donde se requiere una superficie antideslizante.

## Что такое Vogue System

Ceramica Vogue создала Vogue System. Vogue System – это инновационная система, разработанная для каждого вида интерьера, способная удовлетворять проектные потребности архитекторов и дизайнеров. Она состоит из разных отделок одинакового цвета и широкой цветовой гаммы, из 3 базовых квадратных модулей и из 4 базовых прямоугольных модулей. Это идеальное решение для жилой и торговой среды, для наружной облицовки и в том случае, если требуется противоскользящая плитка.

## Vogue 系統是甚麼

陶瓷Vogue 創建了Vogue系統，一個為所有設定類型而設計的創新的陶瓷體系，能滿足室內和建築的設計需求。各種不同的表面擁有同樣廣泛的顏色跨度，有3個正方形基礎模塊和4個長方形基礎模塊可供選擇，使得Vogue成為住宅和商業項目所需瓷磚的理想方案，針對特殊需求和外牆用磚更有防滑產品可供選擇。

## Grip R11 C (A+B+C)

Piacevolmente materica, la superficie di Grip garantisce massima aderenza e sicurezza in ambienti bagnati - R11 C (A+B+C) - rispondendo alle normative vigenti in termini di antiscivolosità. A corredo sono disponibili i pezzi speciali, soluzione ideale per spazi pubblici quali piscine e fitness center.

La superficie de Grip, con una agradable matericidad, garantiza la máxima adherencia y seguridad en lugares mojados - R11 C (A+B+C) - respondiendo a las normativas vigentes en términos de antideslizamiento. Hay piezas especiales disponibles como acompañamiento, una solución ideal para espacios públicos como piscinas y fitness center.

Поверхность Grip гарантирует максимальное сцепление и безопасность в мокрых условиях - R11 C (A+B+C) - соответствуя действующим нормам с точки зрения противоскольжения. В ассортименте имеются также специальные предложения, идеальное решение для общественных заведений, таких как бассейны и фитнес-центры.

質樸而討人喜歡的，防滑表面為濕潤區域 - R11 C (A+B+C) - 提供牢固的安全保障，不同的防滑等級針對不同地面需求。該系列配有特殊配件，該系列配有其他特殊配件，為游泳池和健身中心類公共場所的理想解決方案。

## Flooring R10 A-B

Flooring è la collezione per pavimenti adatta a rispondere alle normative vigenti e alle esigenze pratiche in materia di antiscivolosità in ambienti asciutti/umidi - R10 B (A+B). La superficie ruvida garantisce buona aderenza senza tuttavia trascurare l'attenzione all'estetica e la pulibilità.

Flooring es la colección para pavimentos que responde a las normativas vigentes y a las exigencias prácticas en materia de antideslizamiento en entornos secos/húmedos - R10 B (A+B). La superficie rugosa garantiza una buena adherencia, sin dejar de lado la estética y la facilidad de limpieza.

Flooring – это напольная плитка, соответствующая действующим нормам и практическим потребностям с точки зрения противоскольжения в влажных/сухих условиях - R10 B (A+B). Шероховатая поверхность гарантирует хорошее сцепление, сохраняя красоту и легкость очистки.

地材是遵循相關有效的準則為解決乾濕區域 - R10 B (A+B) 所產生的各種需求的地面瓷磚系列。粗糙表面為安全提供保障同時不會影響清理與美觀。

## Trasparenze

Lucida e brillante, Trasparenze è pensata per rivestimenti di spazi pubblici e privati contraddistinti da gusto ed eleganza. Le finiture del Vogue System si prestano a completare la pavimentazione di ogni ambiente arredato da Trasparenze.

Lustrada y brillante, Trasparenze es ideal para revestimientos de espacios públicos y privados que se distinguen por el buen gusto y la elegancia. Los acabados del Vogue System también se prestan para completar el pavimento de cualquier espacio decorado con Trasparenze.

Trasparenze – это блестящая глянцевая плитка, разработана для общественных и частных интерьеров. Другие поверхности Vogue System подходят для напольной укладки и сочетаются с облицовкой Trasparenze.

光亮而閃耀的，Trasparenze 透明系列設計出高雅的瓷磚專為雅致的公共和私人區域而設。Vogue 系統的不同表面可以與透明系列完全契合而滿足任何地面環境。

## Interni

Estremamente versatile grazie all'ampia scelta di formati modulari corredati di tozzetti e pezzi speciali, Interni può essere abbinata alle altre finiture del Vogue System per arredare interni ed esterni di ambienti pubblici e residenziali.

Siendo muy versátil por la dilatada selección de formatos modulares acompañados por piezas pequeñas y especiales, Interni puede combinarse con otros acabados del Vogue System para decorar interiores y exteriores de espacios públicos y residenciales.

Interni – это гибкое решение для внутренней и наружной отделки в жилых и общественных местах. Коллекция представляет собой большой выбор модульных форматов, специальных элементов и хорошо сочетается с другими отделками Vogue System.

多標準尺寸，嵌入物和特殊配件使得 Interni 系列極其靈活多變。可與 Vogue 系統中其他的表面搭配滿足公共與私人室內與室外的裝飾需求。

IN TR RF IG

ghiaccio	latte	seta	beige	nociola	tortora	rosa	albicocca	papaya	arancio	caffè	bordeaux	rosso	corallo	mandarino	girasole	giallo	cedro	pompelmo
RAL 9003	RAL 9010	RAL 1015	RAL 1001	RAL 8025	RAL 1019	RAL 040 80 10	RAL 060 80 40	RAL 050 70 60	RAL 8023	RAL 050 20 10	RAL 3005	RAL 3020	RAL 2012	RAL 1034	RAL 075 70 70	RAL 1002	RAL 1018	RAL 090 80 30
pag. 26	pag. 28	pag. 30	pag. 32	pag. 34	pag. 36	pag. 38	pag. 40	pag. 42	pag. 44	pag. 46	pag. 48	pag. 50	pag. 52	pag. 54	pag. 56	pag. 58	pag. 60	pag. 62

Utilizzo: interni ed esterni, pavimenti e rivestimenti  
 Uso: interiores y exteriores, pavimentos y revestimientos  
 Использование: внутренняя и наружная отделка, полы и облицовка  
 使用: 室內和室外, 牆地兩用磚

Utilizzo: interni ed esterni, rivestimento  
 Uso: interiores y exteriores, revestimiento  
 Использование: внутренняя и наружная отделка, облицовка  
 使用: 室內和室外, 牆面磚

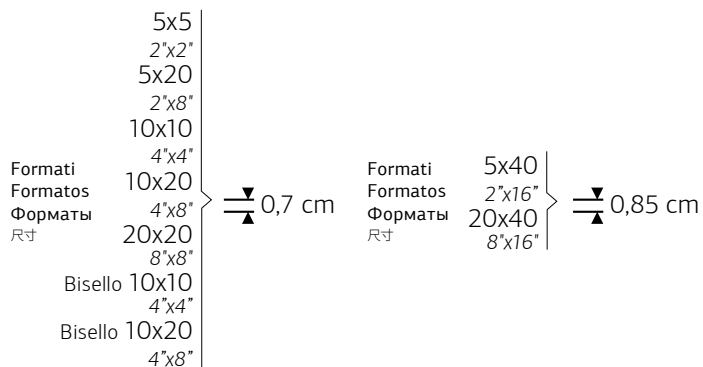
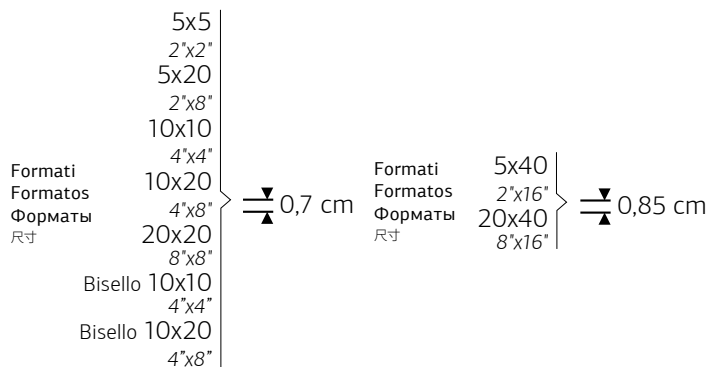

IN - Interni

TR - trasparenze

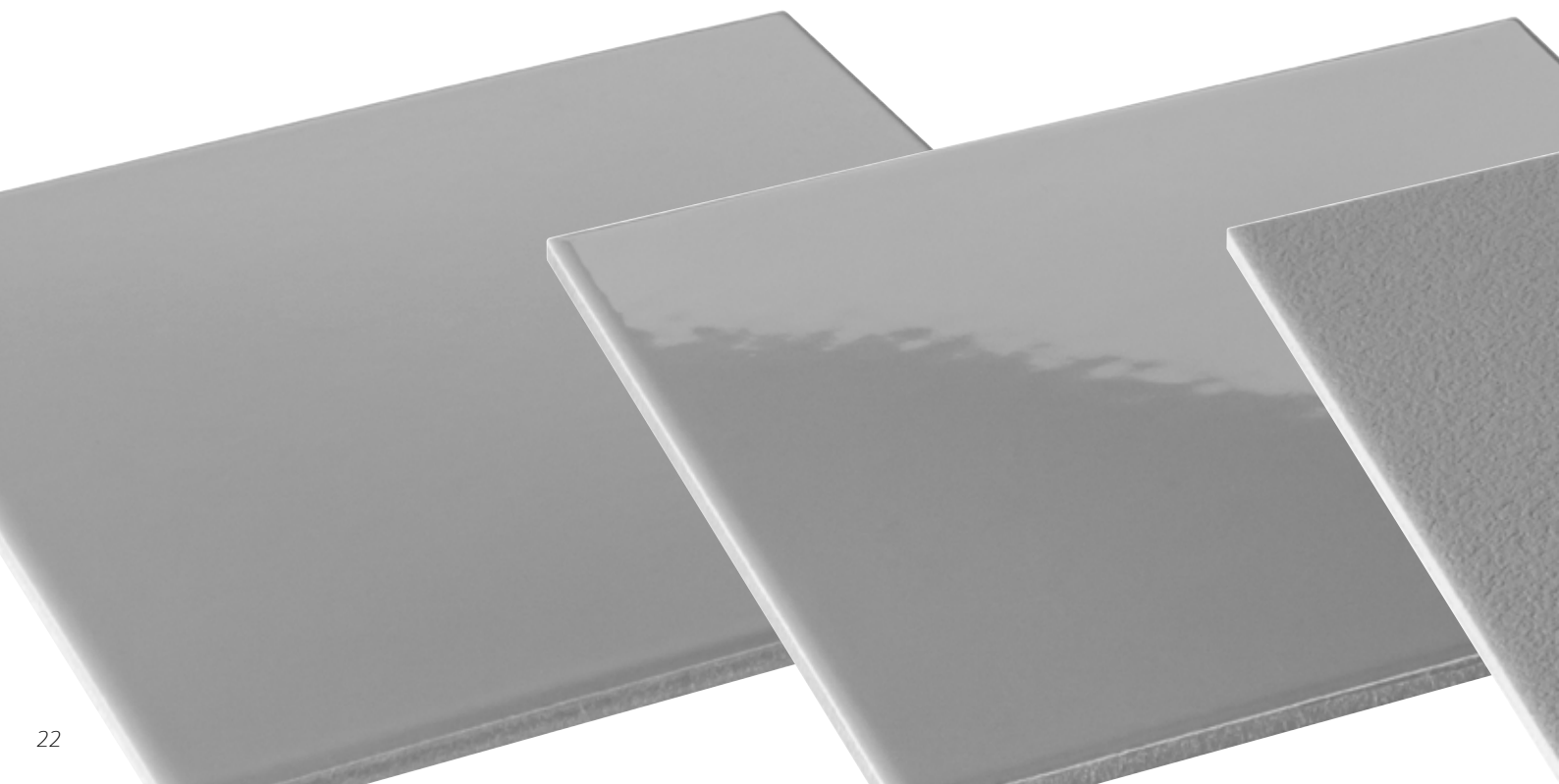

pistacchio	oliva	menta	smeraldo	turchese	giada	laguna	azzurro	cielo	blu avio	oltremare	cobalto	lavanda	lilla	perla	argento	grigio	ferro	nero
RAL 110 80 30	RAL 120 40 20	RAL 60 28	RAL 160 60 25	RAL 60 34	RAL 160 80 10	RAL 180 80 10	RAL 220 80 10	RAL 230 70 20	RAL 50 14	RAL 50 05	RAL 50 22	RAL 40 09	RAL 70 47	RAL 70 04	RAL 70 44	RAL 70 06	RAL 80 19	RAL 90 04
pag. 64	pag. 66	pag. 68	pag. 70	pag. 72	pag. 74	pag. 76	pag. 78	pag. 80	pag. 82	pag. 84	pag. 86	pag. 88	pag. 90	pag. 92	pag. 94	pag. 96	pag. 98	pag. 100

Utilizzo: interni ed esterni, pavimenti umidi - R10 B (A+B)  
 Uso: interiores y exteriores, suelos húmedos - R10 B (A+B)  
 Использование: внутренняя и наружная отделка, влажные полы - R10 B (A+B)  
 使用: 室內和室外, 潮濕地面 - R10 B (A+B)

Utilizzo: interni ed esterni, pavimenti bagnati - R11 C (A+B+C)  
 Uso: interiores y exteriores, suelos mojados - R11 C (A+B+C)  
 Использование: внутренняя и наружная отделка, мокрые полы - R11 C (A+B+C)  
 使用: 室內和室外, 濕潤地面 - R11 C (A+B+C)

Formati 5x5, 2'x2", 10x10, 4'x4", 20x20, 8'x8" }  $\frac{\nabla}{\blacktriangle}$  0,7 cm

Formati 20x40, 8'x16" }  $\frac{\nabla}{\blacktriangle}$  0,85 cm

Formati 5x5, 2'x2", 10x10, 4'x4", 20x20, 8'x8" }  $\frac{\nabla}{\blacktriangle}$  0,7 cm

## RF - Flooring R10 B (A+B)

## IG - Grip R11 C (A+B+C)

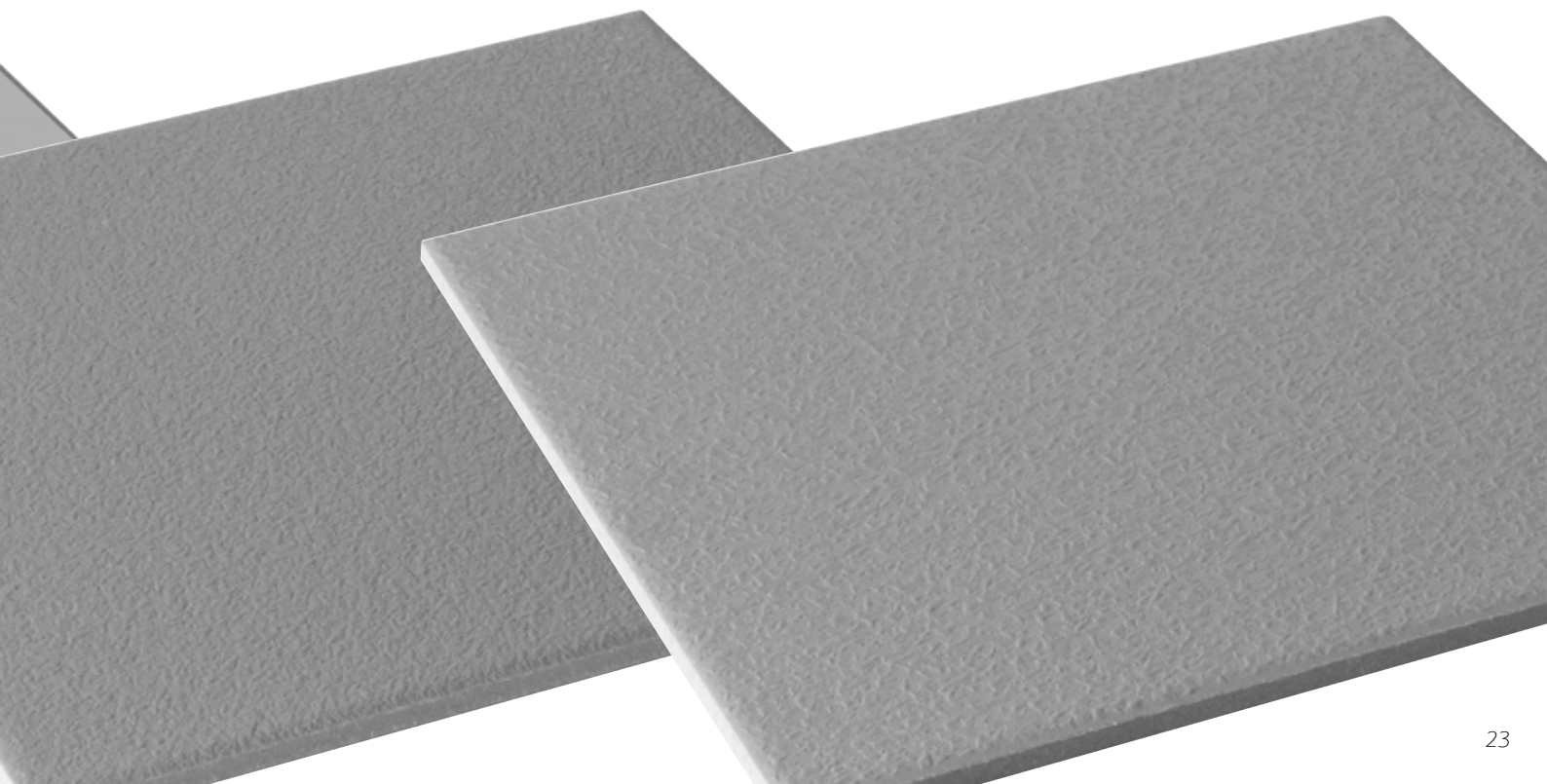

## Pezzi speciali

Una completa gamma di pezzi speciali, disponibili in tutti i colori del Vogue System, risponde a ogni esigenza di progettazione, dalle necessità tecniche a quelle imposte dalle attuali normative in materia di igiene e manutenzione. I pezzi speciali sono disponibili nelle finiture Interni satinata e trasparenze lucida e hanno dimensioni modulari ai formati del Vogue System. Per un più dettagliato elenco si rimanda alle schede dei singoli prodotti.

## Piezas especiales

Una gama completa de piezas especiales, disponibles en todos los colores del Vogue System, responde a cualquier necesidad de diseño, desde aquellas técnicas a aquellas impuestas por las actuales normativas en materia de higiene y mantenimiento. Las piezas especiales están disponibles en los acabados Interni satinado y trasparenze brillante y tienen dimensiones modulares con los formatos del Vogue System. Para una lista más detallada, véase la ficha técnica de cada producto.

## Специальные элементы

Полный ассортимент специальных элементов во всех цветах Vogue System для любых потребностей проектирования, начиная с технических необходимостей до соблюдения норм гигиены и технического обслуживания. Специальные элементы доступны в сатирированной отделке Interni и в глянцевой отделке trasparenze; их размеры соответствуют форматам Vogue System. Более подробный список можно найти в технических данных каждого продукта.

## 特殊配件

一整套特殊配件，擁有 Vogue 系列所有顏色，可滿足所有的設計需求，也同時可滿足技術要求和衛生維護所產生的相關需求。這些特殊配件們擁有亞光 Interni 和亮光 trasparenze 表面擁有 Vogue 系統的所有標準尺寸。如欲瞭解詳細信息請參考相關產品的獨立附錄信息。

### Interni/Trasparenze *superficie satinata/lucida superficie satinada/brillante сатирированная/Глянцевая поверхность 亞光施輪表面/亮光表面*



**Cod. M**  
[IN/TR]  
2,5x20 cm  
1'x8"



**Cod. N**  
[IN/TR]  
2,5x20 cm  
1'x8"



**Cod. W**  
[IN/TR]  
2,5x10 cm  
1'x4"



**Cod. K**  
[IN/TR]  
2,5x10 cm  
1'x4"



**Cod. G**  
[IN]  
2,5x10 cm  
1'x4"



**Cod. H**  
[IN]  
2,5x10 cm  
1'x4"

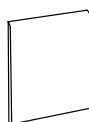

**Cod. U**  
[IN]  
10x10 cm  
4'x4"

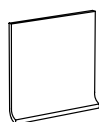

**Cod. Z**  
[IN]  
10x10 cm  
4'x4"

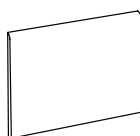

**Cod. X**  
[IN]  
10x20 cm  
4'x8"

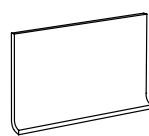

**Cod. I**  
[IN]  
10x20 cm  
4'x8"



**Cod. C**  
[IN/TR]  
2,5x2,5 cm  
1'x1"



**Cod. D**  
[IN/TR]  
2,5x2,5 cm  
1'x1"



**Cod. F**  
[IN/TR]  
2,5x2,5 cm  
1'x1"



**Cod. E**  
[IN/TR]  
2,5x2,5 cm  
1'x1"

### Grip *superficie antiscivolo satinata superficie antideslizante satinada противоскользкая сатирированная поверхность 亞光施輪防滑表面*

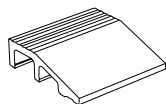

**Bordo Cod. B**  
10x10 cm  
4'x4"

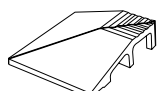

**Angolo Cod. I**  
10x10 cm  
4'x4"

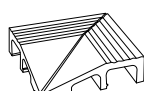

**Spigolo Cod. E**  
10x10 cm  
4'x4"



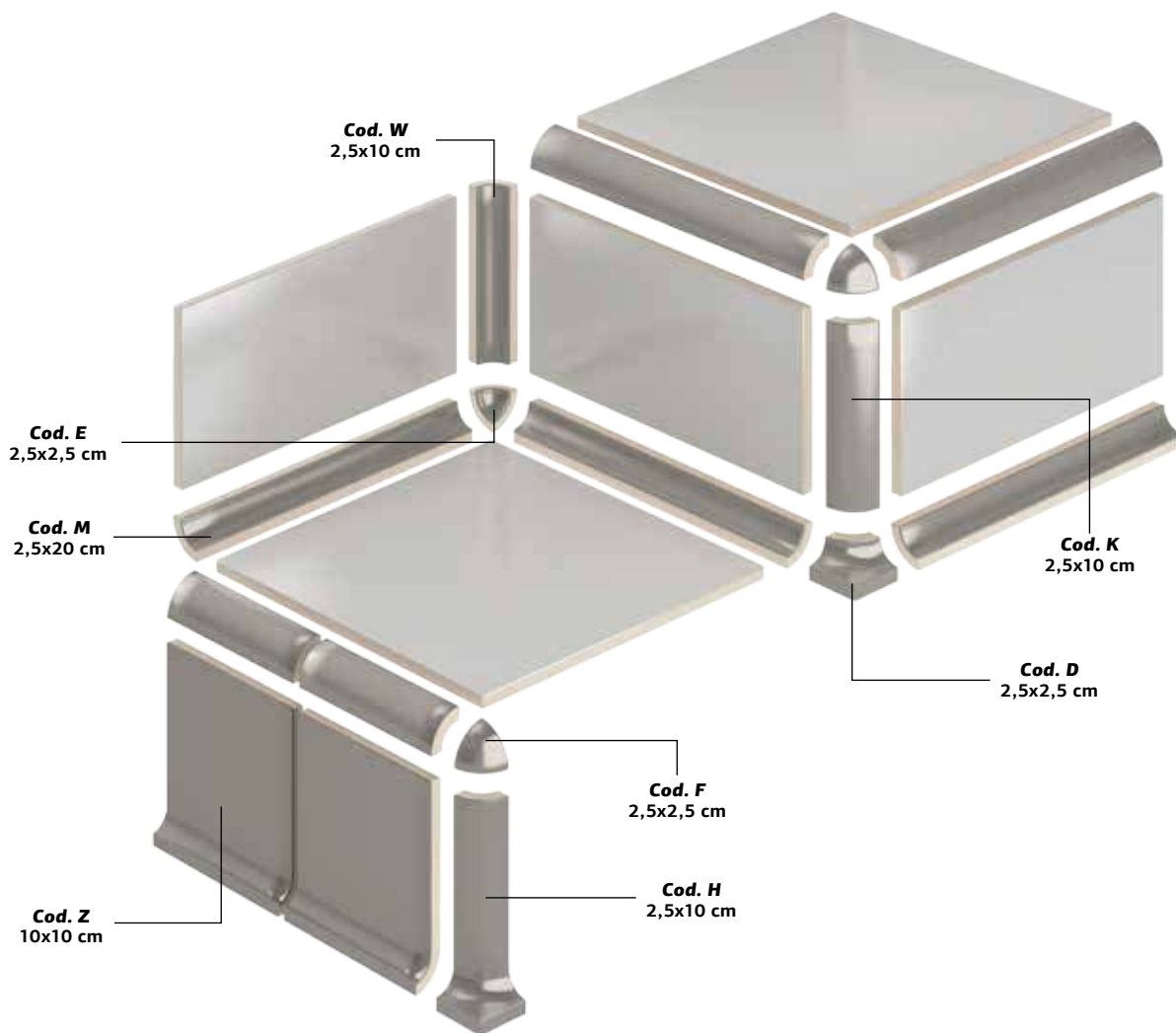
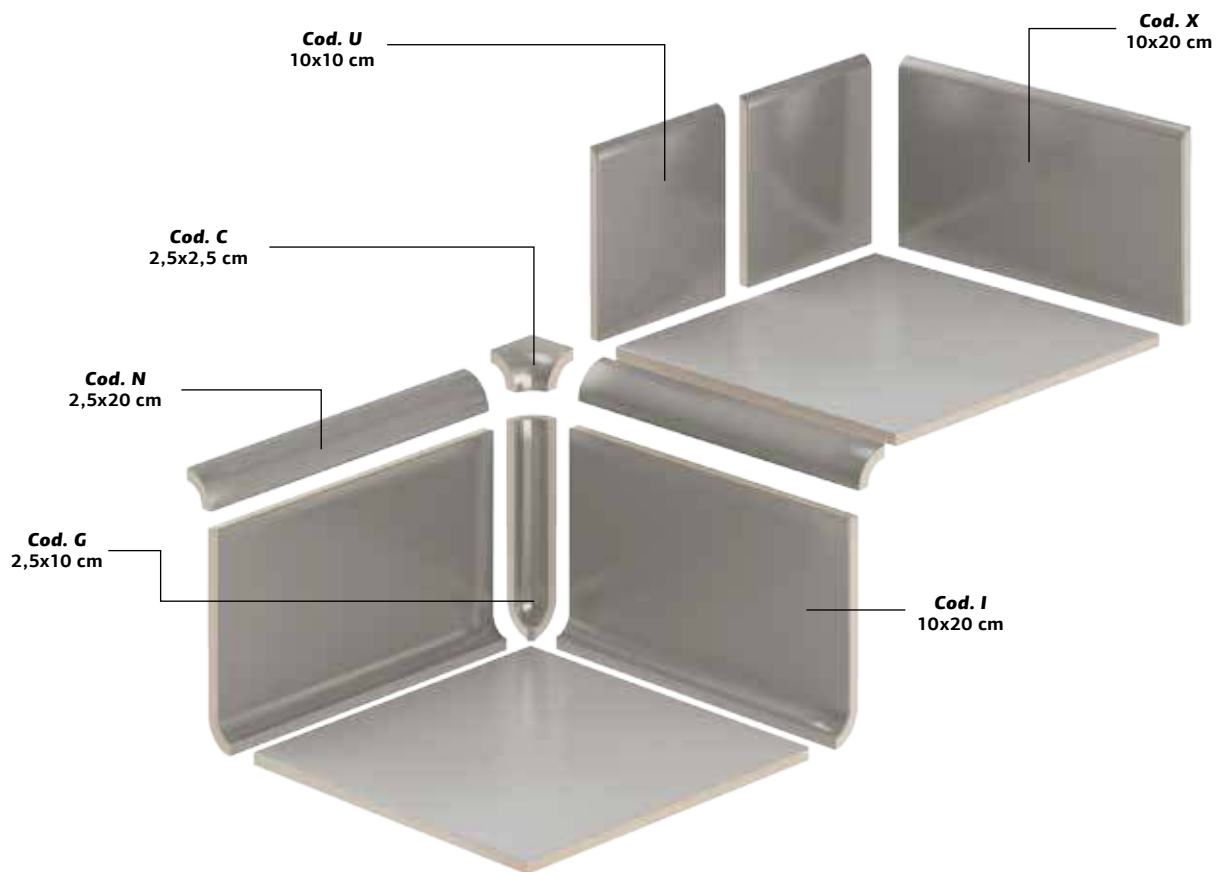

5x5 cm



10x10 cm



20x20 cm



**Bordo Cod. B**  
10x10 cm



**Angolo Cod. I**  
10x10 cm



**Spigolo Cod. E**  
10x10 cm

5x5 cm



10x10 cm



20x20 cm



20x40 cm



5x5 cm



10x10 cm



**Bisello**  
10x10 cm



20x20 cm



20x40 cm

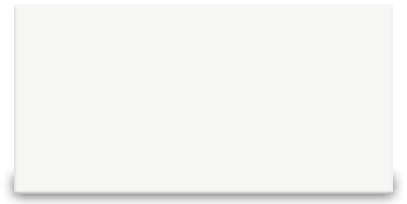

**Stick**  
1,2x20 cm



**Cod. M**  
2,5x20 cm



**Cod. N**  
2,5x20 cm



**Cod. W**  
2,5x10 cm



**Cod. K**  
2,5x10 cm



**Cod. E**  
2,5x2,5 cm



**Cod. F**  
2,5x2,5 cm

5x5 cm



10x10 cm



**Bisello**  
10x10 cm



20x20 cm

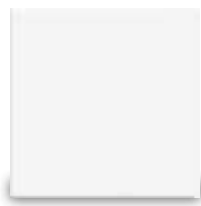

20x40 cm

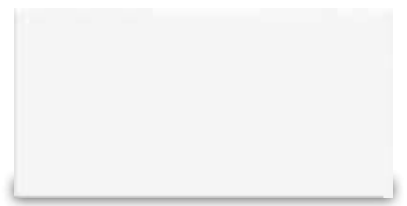

**Quadra**  
2,5x20 cm



**Stick**  
1,2x20 cm



**Cod. M**  
2,5x20 cm



**Cod. N**  
2,5x20 cm



**Cod. W**  
2,5x10 cm



**Cod. K**  
2,5x10 cm



**Cod. G**  
2,5x10 cm



**Cod. H**  
2,5x10 cm



**Cod. E**  
2,5x2,5 cm



**Cod. F**  
2,5x2,5 cm

P.E.I. ④

IG

P.E.I. ④

RF

P.E.I. ④

TR

P.E.I. ④

IN

10x20 cm

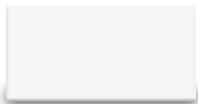

**Bisello**  
10x20 cm

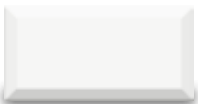

5x20 cm



5x40 cm

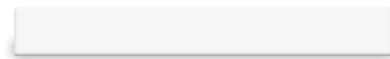

  
**Cod. C**  
2,5x2,5 cm

  
**Cod. D**  
2,5x2,5 cm

10x20 cm

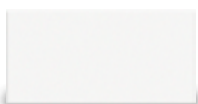

**Bisello**  
10x20 cm

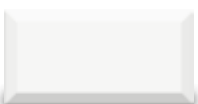

5x20 cm

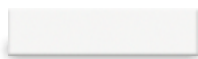

5x40 cm

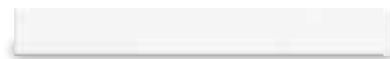

  
**Cod. C**  
2,5x2,5 cm

  
**Cod. D**  
2,5x2,5 cm

  
**Cod. U**  
10x10 cm

  
**Cod. Z**  
10x10 cm

  
**Cod. X**  
10x20 cm

  
**Cod. I**  
10x20 cm

5x5 cm



10x10 cm



20x20 cm

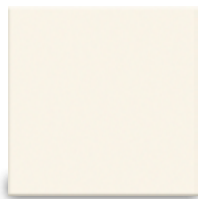

20x40 cm



**Quadra**  
2,5x20 cm



**Stick**  
1,2x20 cm



**Cod. M**  
2,5x20 cm



**Cod. N**  
2,5x20 cm



**Cod. W**  
2,5x10 cm



**Cod. K**  
2,5x10 cm



**Cod. G**  
2,5x10 cm



**Cod. H**  
2,5x10 cm



**Cod. E**  
2,5x2,5 cm



**Cod. F**  
2,5x2,5 cm

IG

RF

TR

IN

P.E.I. ④

10x20 cm

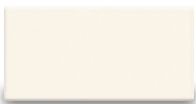

5x20 cm



5x40 cm

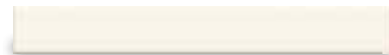

**Cod. C**  
2,5x2,5 cm

**Cod. D**  
2,5x2,5 cm

**Cod. U**  
10x10 cm

**Cod. Z**  
10x10 cm

**Cod. X**  
10x20 cm

**Cod. I**  
10x20 cm

5x5 cm



10x10 cm



20x20 cm



**Bordo Cod. B**  
10x10 cm



**Angolo Cod. I**  
10x10 cm



**Spigolo Cod. E**  
10x10 cm

5x5 cm



10x10 cm



20x20 cm



20x40 cm



5x5 cm



10x10 cm



**Bisello**  
10x10 cm



20x20 cm

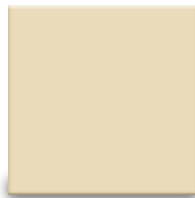

20x40 cm

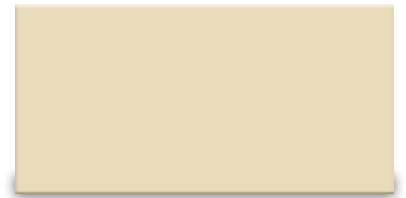

**Stick**  
1,2x20 cm



**Cod. M**  
2,5x20 cm



**Cod. N**  
2,5x20 cm



**Cod. W**  
2,5x10 cm



**Cod. K**  
2,5x10 cm



**Cod. E**  
2,5x2,5 cm



**Cod. F**  
2,5x2,5 cm

5x5 cm



10x10 cm



20x20 cm

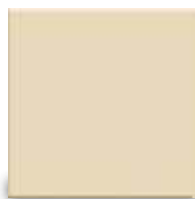

20x40 cm

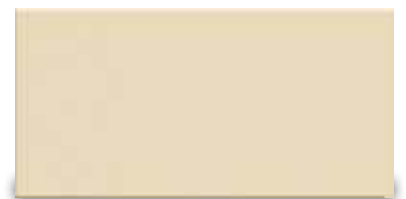

**Quadra**  
2,5x20 cm



**Stick**  
1,2x20 cm



**Cod. M**  
2,5x20 cm



**Cod. N**  
2,5x20 cm



**Cod. W**  
2,5x10 cm



**Cod. K**  
2,5x10 cm



**Cod. G**  
2,5x10 cm



**Cod. H**  
2,5x10 cm



**Cod. E**  
2,5x2,5 cm



**Cod. F**  
2,5x2,5 cm

P.E.I. ④

IG

P.E.I. ④

RF

P.E.I. ③

TR

P.E.I. ④

IN

10x20 cm

**Bisello**  
10x20 cm

5x20 cm

5x40 cm

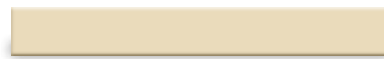
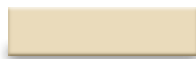

**Cod. C**  
2,5x2,5 cm



**Cod. D**  
2,5x2,5 cm

10x20 cm

**Bisello**  
10x20 cm

5x20 cm

5x40 cm

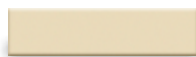
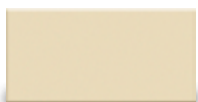

**Cod. C**  
2,5x2,5 cm



**Cod. D**  
2,5x2,5 cm



**Cod. U**  
10x10 cm



**Cod. Z**  
10x10 cm



**Cod. X**  
10x20 cm



**Cod. I**  
10x20 cm

5x5 cm



10x10 cm



20x20 cm

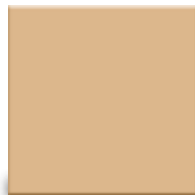

20x40 cm



**Stick**  
1,2x20 cm



**Cod. M**  
2,5x20 cm



**Cod. N**  
2,5x20 cm



**Cod. W**  
2,5x10 cm



**Cod. K**  
2,5x10 cm



**Cod. E**  
2,5x2,5 cm



**Cod. F**  
2,5x2,5 cm

5x5 cm



10x10 cm



20x20 cm



20x40 cm



**Quadra**  
2,5x20 cm



**Stick**  
1,2x20 cm



**Cod. M**  
2,5x20 cm



**Cod. N**  
2,5x20 cm



**Cod. W**  
2,5x10 cm



**Cod. K**  
2,5x10 cm



**Cod. G**  
2,5x10 cm



**Cod. H**  
2,5x10 cm



**Cod. E**  
2,5x2,5 cm



**Cod. F**  
2,5x2,5 cm



IG

RF

TR

IN

10x20 cm



5x20 cm



5x40 cm



P.E.I. ③



**Cod. C**  
2,5x2,5 cm



**Cod. D**  
2,5x2,5 cm

10x20 cm

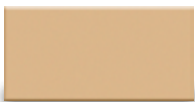

5x20 cm



5x40 cm



P.E.I. ④



**Cod. C**  
2,5x2,5 cm



**Cod. D**  
2,5x2,5 cm



**Cod. U**  
10x10 cm



**Cod. Z**  
10x10 cm



**Cod. X**  
10x20 cm



**Cod. I**  
10x20 cm

5x5 cm



10x10 cm



20x20 cm



20x40 cm



**Quadra**  
2,5x20 cm



**Stick**  
1,2x20 cm



**Cod. M**  
2,5x20 cm



**Cod. N**  
2,5x20 cm



**Cod. W**  
2,5x10 cm



**Cod. K**  
2,5x10 cm



**Cod. G**  
2,5x10 cm



**Cod. H**  
2,5x10 cm



**Cod. E**  
2,5x2,5 cm



**Cod. F**  
2,5x2,5 cm

IG

RF

TR

P.E.I. ②

IN

10x20 cm



5x20 cm



5x40 cm



**Cod. C**  
2,5x2,5 cm

**Cod. D**  
2,5x2,5 cm

**Cod. U**  
10x10 cm

**Cod. Z**  
10x10 cm

**Cod. X**  
10x20 cm

**Cod. I**  
10x20 cm

5x5 cm



10x10 cm



20x20 cm



20x40 cm



**Quadra**  
2,5x20 cm



**Stick**  
1,2x20 cm



**Cod. M**  
2,5x20 cm



**Cod. N**  
2,5x20 cm



**Cod. W**  
2,5x10 cm



**Cod. K**  
2,5x10 cm



**Cod. G**  
2,5x10 cm



**Cod. H**  
2,5x10 cm



**Cod. E**  
2,5x2,5 cm



**Cod. F**  
2,5x2,5 cm

IG

RF

TR

**Bisello**  
10x20 cm



10x20 cm



**Bisello**  
10x20 cm



5x20 cm



5x40 cm



P.E.I. ③

IN

**Cod. C**  
2,5x2,5 cm



**Cod. D**  
2,5x2,5 cm



**Cod. U**  
10x10 cm



**Cod. Z**  
10x10 cm



**Cod. X**  
10x20 cm



**Cod. I**  
10x20 cm



5x5 cm



10x10 cm



20x20 cm



20x40 cm



**Stick**  
1,2x20 cm



**Cod. M**  
2,5x20 cm



**Cod. N**  
2,5x20 cm



**Cod. W**  
2,5x10 cm



**Cod. K**  
2,5x10 cm



**Cod. E**  
2,5x2,5 cm



**Cod. F**  
2,5x2,5 cm

5x5 cm



10x10 cm



20x20 cm

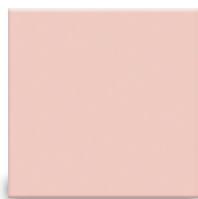

20x40 cm

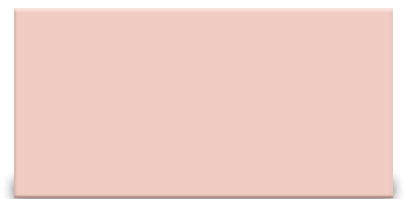

**Quadra**  
2,5x20 cm



**Stick**  
1,2x20 cm



**Cod. M**  
2,5x20 cm



**Cod. N**  
2,5x20 cm



**Cod. W**  
2,5x10 cm



**Cod. K**  
2,5x10 cm



**Cod. G**  
2,5x10 cm



**Cod. H**  
2,5x10 cm



**Cod. E**  
2,5x2,5 cm



**Cod. F**  
2,5x2,5 cm

IG

RF

TR

IN

10x20 cm

**Bisello**  
10x20 cm

5x20 cm

5x40 cm

P.E.I. ③

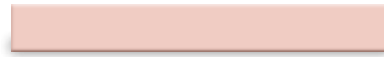
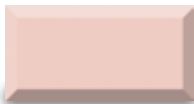
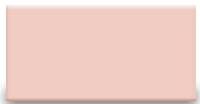

  
**Cod. C**  
2,5x2,5 cm

  
**Cod. D**  
2,5x2,5 cm

10x20 cm

**Bisello**  
10x20 cm

5x20 cm

5x40 cm

P.E.I. ④

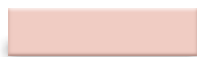
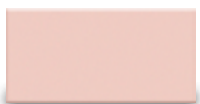

  
**Cod. C**  
2,5x2,5 cm

  
**Cod. D**  
2,5x2,5 cm

  
**Cod. U**  
10x10 cm

  
**Cod. Z**  
10x10 cm

  
**Cod. X**  
10x20 cm

  
**Cod. I**  
10x20 cm

5x5 cm



10x10 cm



20x20 cm



20x40 cm

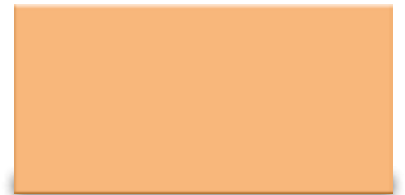

**Stick**  
1,2x20 cm



**Cod. M**  
2,5x20 cm



**Cod. N**  
2,5x20 cm



**Cod. W**  
2,5x10 cm



**Cod. K**  
2,5x10 cm



**Cod. E**  
2,5x2,5 cm



**Cod. F**  
2,5x2,5 cm

5x5 cm



10x10 cm



20x20 cm



20x40 cm



**Quadra**  
2,5x20 cm



**Stick**  
1,2x20 cm



**Cod. M**  
2,5x20 cm



**Cod. N**  
2,5x20 cm



**Cod. W**  
2,5x10 cm



**Cod. K**  
2,5x10 cm



**Cod. G**  
2,5x10 cm



**Cod. H**  
2,5x10 cm



**Cod. E**  
2,5x2,5 cm



**Cod. F**  
2,5x2,5 cm



IG

RF

TR

IN

10x20 cm



5x20 cm



5x40 cm



P.E.I. ②



**Cod. C**  
2,5x2,5 cm



**Cod. D**  
2,5x2,5 cm

10x20 cm

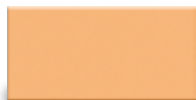

5x20 cm



5x40 cm



P.E.I. ③



**Cod. C**  
2,5x2,5 cm



**Cod. D**  
2,5x2,5 cm



**Cod. U**  
10x10 cm



**Cod. Z**  
10x10 cm



**Cod. X**  
10x20 cm



**Cod. I**  
10x20 cm

5x5 cm



10x10 cm



20x20 cm



20x40 cm



**Stick**  
1,2x20 cm



**Cod. M**  
2,5x20 cm



**Cod. N**  
2,5x20 cm



**Cod. W**  
2,5x10 cm



**Cod. K**  
2,5x10 cm



**Cod. E**  
2,5x2,5 cm



**Cod. F**  
2,5x2,5 cm

5x5 cm



10x10 cm



20x20 cm



20x40 cm



**Quadra**  
2,5x20 cm



**Stick**  
1,2x20 cm



**Cod. M**  
2,5x20 cm



**Cod. N**  
2,5x20 cm



**Cod. W**  
2,5x10 cm



**Cod. K**  
2,5x10 cm



**Cod. G**  
2,5x10 cm



**Cod. H**  
2,5x10 cm



**Cod. E**  
2,5x2,5 cm



**Cod. F**  
2,5x2,5 cm

**IG**

**RF**

**TR**

**IN**

10x20 cm



5x20 cm



5x40 cm



P.E.I. ③



**Cod. C**  
2,5x2,5 cm



**Cod. D**  
2,5x2,5 cm

10x20 cm



5x20 cm



5x40 cm



P.E.I. ③



**Cod. C**  
2,5x2,5 cm



**Cod. D**  
2,5x2,5 cm



**Cod. U**  
10x10 cm



**Cod. Z**  
10x10 cm



**Cod. X**  
10x20 cm



**Cod. I**  
10x20 cm

5x5 cm



10x10 cm



20x20 cm



20x40 cm



**Quadra**  
2,5x20 cm

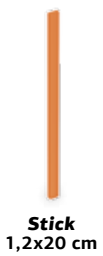

**Stick**  
1,2x20 cm



**Cod. M**  
2,5x20 cm

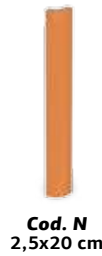

**Cod. N**  
2,5x20 cm



**Cod. W**  
2,5x10 cm



**Cod. K**  
2,5x10 cm



**Cod. G**  
2,5x10 cm



**Cod. H**  
2,5x10 cm



**Cod. E**  
2,5x2,5 cm



**Cod. F**  
2,5x2,5 cm

IG

RF

TR

P.E.I. ©

IN

10x20 cm



5x20 cm



5x40 cm



**Cod. C**  
2,5x2,5 cm

**Cod. D**  
2,5x2,5 cm

**Cod. U**  
10x10 cm

**Cod. Z**  
10x10 cm

**Cod. X**  
10x20 cm

**Cod. I**  
10x20 cm

5x5 cm



10x10 cm



20x20 cm



20x40 cm



**Stick**  
1,2x20 cm



**Cod. M**  
2,5x20 cm



**Cod. N**  
2,5x20 cm



**Cod. W**  
2,5x10 cm



**Cod. K**  
2,5x10 cm



**Cod. E**  
2,5x2,5 cm



**Cod. F**  
2,5x2,5 cm

5x5 cm



10x10 cm



20x20 cm



20x40 cm

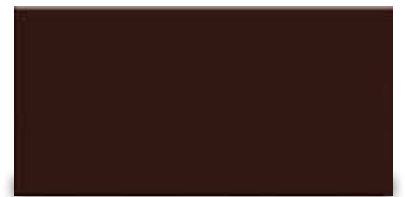

**Quadra**  
2,5x20 cm



**Stick**  
1,2x20 cm



**Cod. M**  
2,5x20 cm



**Cod. N**  
2,5x20 cm



**Cod. W**  
2,5x10 cm



**Cod. K**  
2,5x10 cm



**Cod. G**  
2,5x10 cm



**Cod. H**  
2,5x10 cm



**Cod. E**  
2,5x2,5 cm



**Cod. F**  
2,5x2,5 cm

IG

RF

TR

IN

10x20 cm



5x20 cm



5x40 cm



P.E.I. ①



**Cod. C**  
2,5x2,5 cm



**Cod. D**  
2,5x2,5 cm

10x20 cm



5x20 cm



5x40 cm



P.E.I. ①



**Cod. C**  
2,5x2,5 cm



**Cod. D**  
2,5x2,5 cm



**Cod. U**  
10x10 cm



**Cod. Z**  
10x10 cm



**Cod. X**  
10x20 cm



**Cod. I**  
10x20 cm

5x5 cm



10x10 cm



20x20 cm



20x40 cm



**Quadra**  
2,5x20 cm



**Stick**  
1,2x20 cm



**Cod. M**  
2,5x20 cm



**Cod. N**  
2,5x20 cm



**Cod. W**  
2,5x10 cm



**Cod. K**  
2,5x10 cm



**Cod. G**  
2,5x10 cm



**Cod. H**  
2,5x10 cm



**Cod. E**  
2,5x2,5 cm



**Cod. F**  
2,5x2,5 cm



IG

RF

TR

**Bisello**  
10x20 cm



10x20 cm



**Bisello**  
10x20 cm



5x20 cm



5x40 cm



P.E.I. ①

IN

**Cod. C**  
2,5x2,5 cm



**Cod. D**  
2,5x2,5 cm



**Cod. U**  
10x10 cm



**Cod. Z**  
10x10 cm



**Cod. X**  
10x20 cm



**Cod. I**  
10x20 cm



5x5 cm



10x10 cm



20x20 cm



**Bordo Cod. B**  
10x10 cm



**Angolo Cod. I**  
10x10 cm



**Spigolo Cod. E**  
10x10 cm

5x5 cm



10x10 cm



20x20 cm



20x40 cm



5x5 cm



10x10 cm



20x20 cm



20x40 cm



**Stick**  
1,2x20 cm



**Cod. M**  
2,5x20 cm



**Cod. N**  
2,5x20 cm



**Cod. W**  
2,5x10 cm



**Cod. K**  
2,5x10 cm



**Cod. E**  
2,5x2,5 cm



**Cod. F**  
2,5x2,5 cm

5x5 cm



10x10 cm



20x20 cm



20x40 cm



**Quadra**  
2,5x20 cm



**Stick**  
1,2x20 cm



**Cod. M**  
2,5x20 cm



**Cod. N**  
2,5x20 cm



**Cod. W**  
2,5x10 cm



**Cod. K**  
2,5x10 cm



**Cod. G**  
2,5x10 cm



**Cod. H**  
2,5x10 cm



**Cod. E**  
2,5x2,5 cm



**Cod. F**  
2,5x2,5 cm

P.E.I. ③

**IG**

P.E.I. ③

**RF**

P.E.I. ②

**TR**

P.E.I. ②

**IN**

10x20 cm

**Bisello**  
10x20 cm

5x20 cm

5x40 cm



  
**Cod. C**  
2,5x2,5 cm

  
**Cod. D**  
2,5x2,5 cm

10x20 cm

**Bisello**  
10x20 cm

5x20 cm

5x40 cm



  
**Cod. C**  
2,5x2,5 cm

  
**Cod. D**  
2,5x2,5 cm

  
**Cod. U**  
10x10 cm

  
**Cod. Z**  
10x10 cm

  
**Cod. X**  
10x20 cm

  
**Cod. I**  
10x20 cm

5x5 cm



10x10 cm



20x20 cm

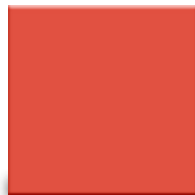

20x40 cm



**Stick**  
1,2x20 cm



**Cod. M**  
2,5x20 cm



**Cod. N**  
2,5x20 cm



**Cod. W**  
2,5x10 cm



**Cod. K**  
2,5x10 cm



**Cod. E**  
2,5x2,5 cm



**Cod. F**  
2,5x2,5 cm

5x5 cm



10x10 cm



20x20 cm



20x40 cm

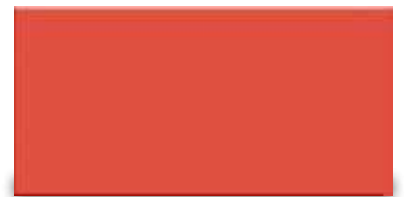

**Quadra**  
2,5x20 cm



**Stick**  
1,2x20 cm



**Cod. M**  
2,5x20 cm



**Cod. N**  
2,5x20 cm



**Cod. W**  
2,5x10 cm



**Cod. K**  
2,5x10 cm



**Cod. G**  
2,5x10 cm



**Cod. H**  
2,5x10 cm



**Cod. E**  
2,5x2,5 cm



**Cod. F**  
2,5x2,5 cm

IG

RF

TR

IN

10x20 cm



5x20 cm



5x40 cm



P.E.I. ②

  
**Cod. C**  
2,5x2,5 cm

  
**Cod. D**  
2,5x2,5 cm

10x20 cm



5x20 cm



5x40 cm



P.E.I. ②

  
**Cod. C**  
2,5x2,5 cm

  
**Cod. D**  
2,5x2,5 cm

  
**Cod. U**  
10x10 cm

  
**Cod. Z**  
10x10 cm

  
**Cod. X**  
10x20 cm

  
**Cod. I**  
10x20 cm

5x5 cm



10x10 cm



20x20 cm



**Bordo Cod. B**  
10x10 cm



**Angolo Cod. I**  
10x10 cm



**Spigolo Cod. E**  
10x10 cm

5x5 cm



10x10 cm



20x20 cm



20x40 cm



5x5 cm



10x10 cm



20x20 cm

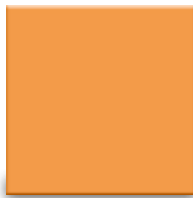

20x40 cm



**Stick**  
1,2x20 cm



**Cod. M**  
2,5x20 cm



**Cod. N**  
2,5x20 cm



**Cod. W**  
2,5x10 cm



**Cod. K**  
2,5x10 cm



**Cod. E**  
2,5x2,5 cm



**Cod. F**  
2,5x2,5 cm

5x5 cm



10x10 cm



20x20 cm



20x40 cm



**Quadra**  
2,5x20 cm



**Stick**  
1,2x20 cm



**Cod. M**  
2,5x20 cm



**Cod. N**  
2,5x20 cm



**Cod. W**  
2,5x10 cm



**Cod. K**  
2,5x10 cm



**Cod. G**  
2,5x10 cm



**Cod. H**  
2,5x10 cm



**Cod. E**  
2,5x2,5 cm



**Cod. F**  
2,5x2,5 cm

P.E.I. ③

IG

P.E.I. ③

RF

P.E.I. ②

TR

P.E.I. ③

IN

10x20 cm

**Bisello**  
10x20 cm

5x20 cm

5x40 cm



**Cod. C**  
2,5x2,5 cm



**Cod. D**  
2,5x2,5 cm

10x20 cm

**Bisello**  
10x20 cm

5x20 cm

5x40 cm



**Cod. C**  
2,5x2,5 cm



**Cod. D**  
2,5x2,5 cm



**Cod. U**  
10x10 cm



**Cod. Z**  
10x10 cm



**Cod. X**  
10x20 cm

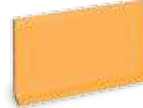

**Cod. I**  
10x20 cm

5x5 cm



10x10 cm



20x20 cm



20x40 cm



**Quadra**  
2,5x20 cm



**Stick**  
1,2x20 cm



**Cod. M**  
2,5x20 cm



**Cod. N**  
2,5x20 cm



**Cod. W**  
2,5x10 cm



**Cod. K**  
2,5x10 cm



**Cod. G**  
2,5x10 cm



**Cod. H**  
2,5x10 cm



**Cod. E**  
2,5x2,5 cm



**Cod. F**  
2,5x2,5 cm



**IG**

**RF**

**TR**

P.E.I. ④

**IN**

10x20 cm



5x20 cm



5x40 cm



**Cod. C**  
2,5x2,5 cm

**Cod. D**  
2,5x2,5 cm

**Cod. U**  
10x10 cm

**Cod. Z**  
10x10 cm

**Cod. X**  
10x20 cm

**Cod. I**  
10x20 cm

5x5 cm



10x10 cm



20x20 cm



**Bordo Cod. B**  
10x10 cm



**Angolo Cod. I**  
10x10 cm



**Spigolo Cod. E**  
10x10 cm

5x5 cm



10x10 cm



20x20 cm



20x40 cm



5x5 cm



10x10 cm



20x20 cm

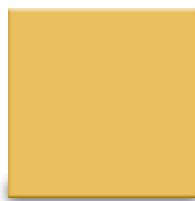

20x40 cm

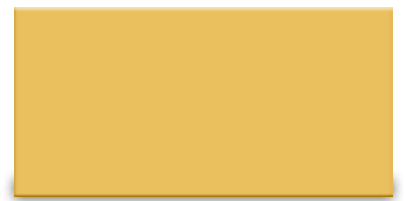

**Stick**  
1,2x20 cm



**Cod. M**  
2,5x20 cm



**Cod. N**  
2,5x20 cm



**Cod. W**  
2,5x10 cm



**Cod. K**  
2,5x10 cm



**Cod. E**  
2,5x2,5 cm



**Cod. F**  
2,5x2,5 cm

5x5 cm



10x10 cm



20x20 cm



20x40 cm



**Quadra**  
2,5x20 cm



**Stick**  
1,2x20 cm



**Cod. M**  
2,5x20 cm



**Cod. N**  
2,5x20 cm



**Cod. W**  
2,5x10 cm



**Cod. K**  
2,5x10 cm



**Cod. G**  
2,5x10 cm



**Cod. H**  
2,5x10 cm



**Cod. E**  
2,5x2,5 cm



**Cod. F**  
2,5x2,5 cm

P.E.I. ③

**IG**

P.E.I. ③

**RF**

P.E.I. ②

**TR**

P.E.I. ③

**IN**

10x20 cm



5x20 cm



5x40 cm



**Cod. C**  
2,5x2,5 cm



**Cod. D**  
2,5x2,5 cm

10x20 cm



5x20 cm



5x40 cm



**Cod. C**  
2,5x2,5 cm



**Cod. D**  
2,5x2,5 cm



**Cod. U**  
10x10 cm



**Cod. Z**  
10x10 cm



**Cod. X**  
10x20 cm



**Cod. I**  
10x20 cm

5x5 cm



10x10 cm



20x20 cm

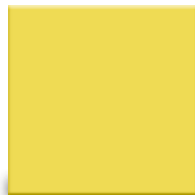

20x40 cm



**Stick**  
1,2x20 cm



**Cod. M**  
2,5x20 cm



**Cod. N**  
2,5x20 cm



**Cod. W**  
2,5x10 cm



**Cod. K**  
2,5x10 cm



**Cod. E**  
2,5x2,5 cm



**Cod. F**  
2,5x2,5 cm

5x5 cm



10x10 cm



20x20 cm



20x40 cm



**Quadra**  
2,5x20 cm



**Stick**  
1,2x20 cm



**Cod. M**  
2,5x20 cm



**Cod. N**  
2,5x20 cm



**Cod. W**  
2,5x10 cm



**Cod. K**  
2,5x10 cm



**Cod. G**  
2,5x10 cm



**Cod. H**  
2,5x10 cm



**Cod. E**  
2,5x2,5 cm



**Cod. F**  
2,5x2,5 cm

IG

RF

TR

IN

10x20 cm

**Bisello**  
10x20 cm

5x20 cm

5x40 cm

P.E.I. ②



**Cod. C**  
2,5x2,5 cm



**Cod. D**  
2,5x2,5 cm

10x20 cm

**Bisello**  
10x20 cm

5x20 cm

5x40 cm

P.E.I. ③



**Cod. C**  
2,5x2,5 cm



**Cod. D**  
2,5x2,5 cm



**Cod. U**  
10x10 cm



**Cod. Z**  
10x10 cm



**Cod. X**  
10x20 cm



**Cod. I**  
10x20 cm

5x5 cm



10x10 cm



20x20 cm

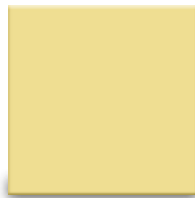

20x40 cm

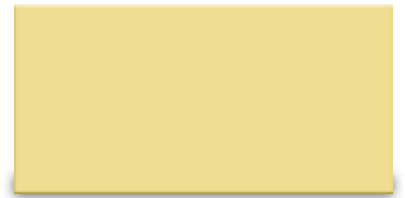

**Stick**  
1,2x20 cm



**Cod. M**  
2,5x20 cm



**Cod. N**  
2,5x20 cm



**Cod. W**  
2,5x10 cm



**Cod. K**  
2,5x10 cm



**Cod. E**  
2,5x2,5 cm



**Cod. F**  
2,5x2,5 cm

5x5 cm



10x10 cm



20x20 cm



20x40 cm



**Quadra**  
2,5x20 cm



**Stick**  
1,2x20 cm



**Cod. M**  
2,5x20 cm



**Cod. N**  
2,5x20 cm



**Cod. W**  
2,5x10 cm



**Cod. K**  
2,5x10 cm



**Cod. G**  
2,5x10 cm



**Cod. H**  
2,5x10 cm



**Cod. E**  
2,5x2,5 cm



**Cod. F**  
2,5x2,5 cm

IG

RF

TR

IN

10x20 cm

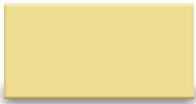

5x20 cm



5x40 cm

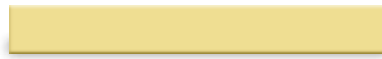

P.E.I. ③



**Cod. C**  
2,5x2,5 cm



**Cod. D**  
2,5x2,5 cm

10x20 cm

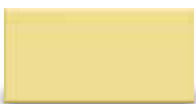

5x20 cm

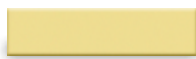

5x40 cm

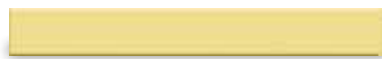

P.E.I. ④



**Cod. C**  
2,5x2,5 cm



**Cod. D**  
2,5x2,5 cm



**Cod. U**  
10x10 cm



**Cod. Z**  
10x10 cm



**Cod. X**  
10x20 cm

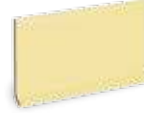

**Cod. I**  
10x20 cm

5x5 cm



10x10 cm



20x20 cm



20x40 cm

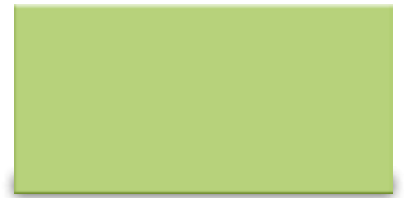

**Stick**  
1,2x20 cm



**Cod. M**  
2,5x20 cm



**Cod. N**  
2,5x20 cm



**Cod. W**  
2,5x10 cm



**Cod. K**  
2,5x10 cm



**Cod. E**  
2,5x2,5 cm



**Cod. F**  
2,5x2,5 cm

5x5 cm



10x10 cm



20x20 cm

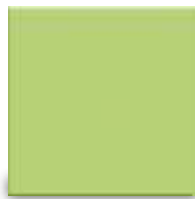

20x40 cm



**Quadra**  
2,5x20 cm



**Stick**  
1,2x20 cm



**Cod. M**  
2,5x20 cm



**Cod. N**  
2,5x20 cm



**Cod. W**  
2,5x10 cm



**Cod. K**  
2,5x10 cm



**Cod. G**  
2,5x10 cm



**Cod. H**  
2,5x10 cm



**Cod. E**  
2,5x2,5 cm



**Cod. F**  
2,5x2,5 cm



**IG**

**RF**

**TR**

**IN**

10x20 cm



5x20 cm



5x40 cm



P.E.I. ③



**Cod. C**  
2,5x2,5 cm



**Cod. D**  
2,5x2,5 cm

10x20 cm



5x20 cm



5x40 cm



P.E.I. ④



**Cod. C**  
2,5x2,5 cm



**Cod. D**  
2,5x2,5 cm



**Cod. U**  
10x10 cm



**Cod. Z**  
10x10 cm



**Cod. X**  
10x20 cm



**Cod. I**  
10x20 cm

5x5 cm



10x10 cm



20x20 cm



20x40 cm



**Quadra**  
2,5x20 cm



**Stick**  
1,2x20 cm



**Cod. M**  
2,5x20 cm



**Cod. N**  
2,5x20 cm



**Cod. W**  
2,5x10 cm



**Cod. K**  
2,5x10 cm



**Cod. G**  
2,5x10 cm



**Cod. H**  
2,5x10 cm



**Cod. E**  
2,5x2,5 cm



**Cod. F**  
2,5x2,5 cm

**IG**

**RF**

**TR**

P.E.I. ②

**IN**

10x20 cm



5x20 cm



5x40 cm



**Cod. C**  
2,5x2,5 cm

**Cod. D**  
2,5x2,5 cm

**Cod. U**  
10x10 cm

**Cod. Z**  
10x10 cm

**Cod. X**  
10x20 cm

**Cod. I**  
10x20 cm

5x5 cm



10x10 cm



20x20 cm



20x40 cm



**Stick**  
1,2x20 cm



**Cod. M**  
2,5x20 cm



**Cod. N**  
2,5x20 cm



**Cod. W**  
2,5x10 cm



**Cod. K**  
2,5x10 cm



**Cod. E**  
2,5x2,5 cm



**Cod. F**  
2,5x2,5 cm

5x5 cm



10x10 cm



20x20 cm



20x40 cm



**Quadra**  
2,5x20 cm



**Stick**  
1,2x20 cm



**Cod. M**  
2,5x20 cm



**Cod. N**  
2,5x20 cm



**Cod. W**  
2,5x10 cm



**Cod. K**  
2,5x10 cm



**Cod. G**  
2,5x10 cm



**Cod. H**  
2,5x10 cm



**Cod. E**  
2,5x2,5 cm



**Cod. F**  
2,5x2,5 cm

IG

RF

TR

IN

10x20 cm

**Bisello**  
10x20 cm

5x20 cm

5x40 cm

P.E.I. ①



  
**Cod. C**  
2,5x2,5 cm

  
**Cod. D**  
2,5x2,5 cm

10x20 cm

**Bisello**  
10x20 cm

5x20 cm

5x40 cm

P.E.I. ①



  
**Cod. C**  
2,5x2,5 cm

  
**Cod. D**  
2,5x2,5 cm

  
**Cod. U**  
10x10 cm

  
**Cod. Z**  
10x10 cm

  
**Cod. X**  
10x20 cm

  
**Cod. I**  
10x20 cm

5x5 cm



10x10 cm



20x20 cm



20x40 cm



**Stick**  
1,2x20 cm



**Cod. M**  
2,5x20 cm



**Cod. N**  
2,5x20 cm



**Cod. W**  
2,5x10 cm



**Cod. K**  
2,5x10 cm



**Cod. E**  
2,5x2,5 cm



**Cod. F**  
2,5x2,5 cm

5x5 cm



10x10 cm



20x20 cm



20x40 cm



**Quadra**  
2,5x20 cm



**Stick**  
1,2x20 cm



**Cod. M**  
2,5x20 cm



**Cod. N**  
2,5x20 cm



**Cod. W**  
2,5x10 cm



**Cod. K**  
2,5x10 cm



**Cod. G**  
2,5x10 cm



**Cod. H**  
2,5x10 cm



**Cod. E**  
2,5x2,5 cm



**Cod. F**  
2,5x2,5 cm

IG

RF

TR

IN

10x20 cm



5x20 cm



5x40 cm



P.E.I. ①



**Cod. C**  
2,5x2,5 cm



**Cod. D**  
2,5x2,5 cm

10x20 cm



5x20 cm



5x40 cm



P.E.I. ②



**Cod. C**  
2,5x2,5 cm



**Cod. D**  
2,5x2,5 cm



**Cod. U**  
10x10 cm



**Cod. Z**  
10x10 cm



**Cod. X**  
10x20 cm



**Cod. I**  
10x20 cm

5x5 cm



10x10 cm



20x20 cm

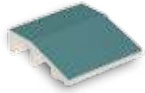

**Bordo Cod. B**  
10x10 cm

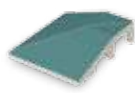

**Angolo Cod. I**  
10x10 cm



**Spigolo Cod. E**  
10x10 cm

5x5 cm



10x10 cm



20x20 cm



20x40 cm



5x5 cm



10x10 cm



20x20 cm



20x40 cm



**Stick**  
1,2x20 cm



**Cod. M**  
2,5x20 cm



**Cod. N**  
2,5x20 cm



**Cod. W**  
2,5x10 cm



**Cod. K**  
2,5x10 cm



**Cod. E**  
2,5x2,5 cm



**Cod. F**  
2,5x2,5 cm

5x5 cm



10x10 cm



20x20 cm



20x40 cm

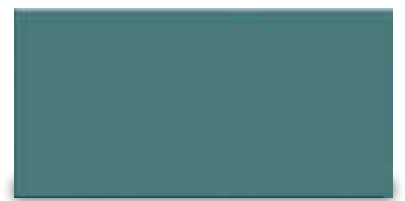

**Quadra**  
2,5x20 cm



**Stick**  
1,2x20 cm



**Cod. M**  
2,5x20 cm



**Cod. N**  
2,5x20 cm



**Cod. W**  
2,5x10 cm



**Cod. K**  
2,5x10 cm



**Cod. G**  
2,5x10 cm



**Cod. H**  
2,5x10 cm



**Cod. E**  
2,5x2,5 cm



**Cod. F**  
2,5x2,5 cm



P.E.I. ② **IG**

P.E.I. ② **RF**

P.E.I. ② **TR**

P.E.I. ② **IN**

10x20 cm

**Bisello**  
10x20 cm

5x20 cm

5x40 cm



  
**Cod. C**  
2,5x2,5 cm

  
**Cod. D**  
2,5x2,5 cm

10x20 cm

**Bisello**  
10x20 cm

5x20 cm

5x40 cm



  
**Cod. C**  
2,5x2,5 cm

  
**Cod. D**  
2,5x2,5 cm

  
**Cod. U**  
10x10 cm

  
**Cod. Z**  
10x10 cm

  
**Cod. X**  
10x20 cm

  
**Cod. I**  
10x20 cm

5x5 cm



10x10 cm



20x20 cm



20x40 cm

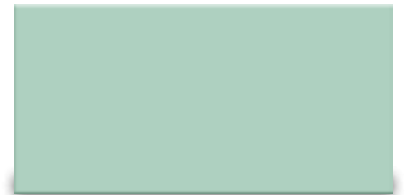

**Stick**  
1,2x20 cm



**Cod. M**  
2,5x20 cm



**Cod. N**  
2,5x20 cm



**Cod. W**  
2,5x10 cm



**Cod. K**  
2,5x10 cm



**Cod. E**  
2,5x2,5 cm



**Cod. F**  
2,5x2,5 cm

5x5 cm



10x10 cm



20x20 cm



20x40 cm



**Quadra**  
2,5x20 cm



**Stick**  
1,2x20 cm



**Cod. M**  
2,5x20 cm



**Cod. N**  
2,5x20 cm



**Cod. W**  
2,5x10 cm



**Cod. K**  
2,5x10 cm



**Cod. G**  
2,5x10 cm



**Cod. H**  
2,5x10 cm



**Cod. E**  
2,5x2,5 cm



**Cod. F**  
2,5x2,5 cm

IG

RF

TR

IN

10x20 cm

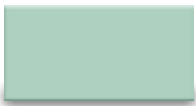

5x20 cm

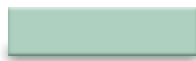

5x40 cm



P.E.I. ③



**Cod. C**  
2,5x2,5 cm



**Cod. D**  
2,5x2,5 cm

10x20 cm



5x20 cm



5x40 cm



P.E.I. ④



**Cod. C**  
2,5x2,5 cm



**Cod. D**  
2,5x2,5 cm



**Cod. U**  
10x10 cm



**Cod. Z**  
10x10 cm



**Cod. X**  
10x20 cm



**Cod. I**  
10x20 cm

5x5 cm



10x10 cm



20x20 cm



**Bordo Cod. B**  
10x10 cm



**Angolo Cod. I**  
10x10 cm



**Spigolo Cod. E**  
10x10 cm

5x5 cm



10x10 cm



20x20 cm



20x40 cm



5x5 cm



10x10 cm



20x20 cm



20x40 cm

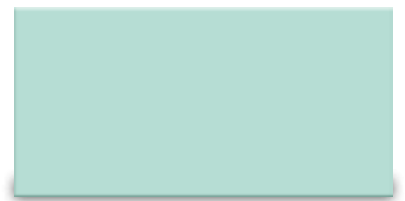

**Stick**  
1,2x20 cm



**Cod. M**  
2,5x20 cm



**Cod. N**  
2,5x20 cm



**Cod. W**  
2,5x10 cm



**Cod. K**  
2,5x10 cm



**Cod. E**  
2,5x2,5 cm



**Cod. F**  
2,5x2,5 cm

5x5 cm



10x10 cm



20x20 cm



20x40 cm

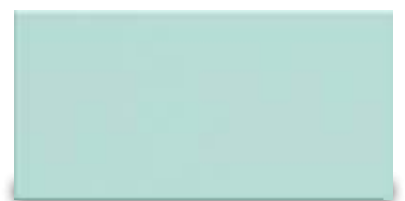

**Quadra**  
2,5x20 cm



**Stick**  
1,2x20 cm



**Cod. M**  
2,5x20 cm



**Cod. N**  
2,5x20 cm



**Cod. W**  
2,5x10 cm



**Cod. K**  
2,5x10 cm



**Cod. G**  
2,5x10 cm



**Cod. H**  
2,5x10 cm



**Cod. E**  
2,5x2,5 cm



**Cod. F**  
2,5x2,5 cm

P.E.I. ④

IG

P.E.I. ④

RF

P.E.I. ③

TR

P.E.I. ④

IN

10x20 cm

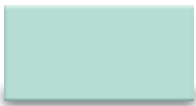

5x20 cm

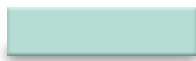

5x40 cm

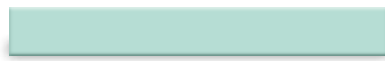

**Cod. C**  
2,5x2,5 cm



**Cod. D**  
2,5x2,5 cm

10x20 cm



5x20 cm

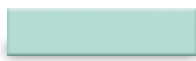

5x40 cm



**Cod. C**  
2,5x2,5 cm



**Cod. D**  
2,5x2,5 cm



**Cod. U**  
10x10 cm



**Cod. Z**  
10x10 cm



**Cod. X**  
10x20 cm



**Cod. I**  
10x20 cm

5x5 cm



10x10 cm



20x20 cm



**Bordo Cod. B**  
10x10 cm



**Angolo Cod. I**  
10x10 cm



**Spigolo Cod. E**  
10x10 cm

5x5 cm



10x10 cm



20x20 cm



20x40 cm



5x5 cm



10x10 cm



20x20 cm

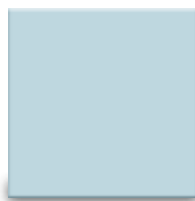

20x40 cm

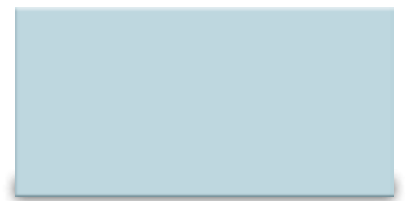

**Stick**  
1,2x20 cm



**Cod. M**  
2,5x20 cm



**Cod. N**  
2,5x20 cm



**Cod. W**  
2,5x10 cm



**Cod. K**  
2,5x10 cm



**Cod. E**  
2,5x2,5 cm



**Cod. F**  
2,5x2,5 cm

5x5 cm



10x10 cm



20x20 cm

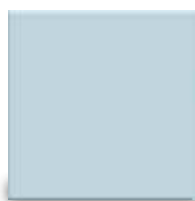

20x40 cm

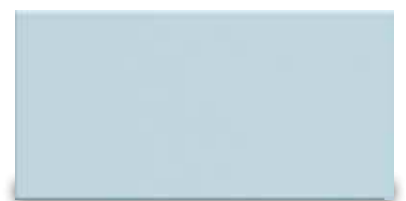

**Quadra**  
2,5x20 cm



**Stick**  
1,2x20 cm



**Cod. M**  
2,5x20 cm



**Cod. N**  
2,5x20 cm



**Cod. W**  
2,5x10 cm



**Cod. K**  
2,5x10 cm



**Cod. G**  
2,5x10 cm



**Cod. H**  
2,5x10 cm



**Cod. E**  
2,5x2,5 cm



**Cod. F**  
2,5x2,5 cm

P.E.I. ④

IG

P.E.I. ④

RF

P.E.I. ③

TR

P.E.I. ④

IN

10x20 cm



5x20 cm



5x40 cm



**Cod. C**  
2,5x2,5 cm



**Cod. D**  
2,5x2,5 cm

10x20 cm

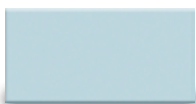

5x20 cm

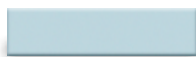

5x40 cm

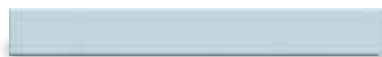

**Cod. C**  
2,5x2,5 cm



**Cod. D**  
2,5x2,5 cm



**Cod. U**  
10x10 cm



**Cod. Z**  
10x10 cm



**Cod. X**  
10x20 cm



**Cod. I**  
10x20 cm

5x5 cm



10x10 cm



20x20 cm



**Bordo Cod. B**  
10x10 cm



**Angolo Cod. I**  
10x10 cm



**Spigolo Cod. E**  
10x10 cm

5x5 cm



10x10 cm



20x20 cm



20x40 cm



5x5 cm



10x10 cm



20x20 cm

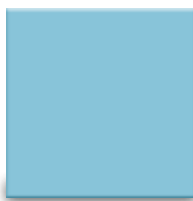

20x40 cm

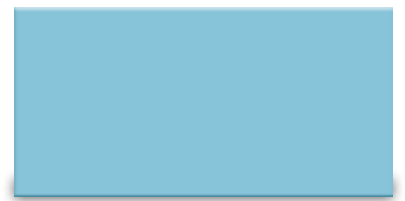

**Stick**  
1,2x20 cm



**Cod. M**  
2,5x20 cm



**Cod. N**  
2,5x20 cm



**Cod. W**  
2,5x10 cm



**Cod. K**  
2,5x10 cm



**Cod. E**  
2,5x2,5 cm



**Cod. F**  
2,5x2,5 cm

5x5 cm



10x10 cm



20x20 cm



20x40 cm

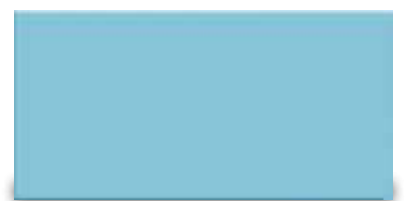

**Quadra**  
2,5x20 cm



**Stick**  
1,2x20 cm



**Cod. M**  
2,5x20 cm



**Cod. N**  
2,5x20 cm



**Cod. W**  
2,5x10 cm



**Cod. K**  
2,5x10 cm



**Cod. G**  
2,5x10 cm



**Cod. H**  
2,5x10 cm



**Cod. E**  
2,5x2,5 cm



**Cod. F**  
2,5x2,5 cm



P.E.I. ③

IG

P.E.I. ③

RF

P.E.I. ②

TR

P.E.I. ③

IN

10x20 cm



5x20 cm



5x40 cm



**Cod. C**  
2,5x2,5 cm



**Cod. D**  
2,5x2,5 cm

10x20 cm



5x20 cm



5x40 cm



**Cod. C**  
2,5x2,5 cm



**Cod. D**  
2,5x2,5 cm



**Cod. U**  
10x10 cm



**Cod. Z**  
10x10 cm



**Cod. X**  
10x20 cm



**Cod. I**  
10x20 cm

5x5 cm



10x10 cm



20x20 cm



**Bordo Cod. B**  
10x10 cm

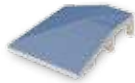

**Angolo Cod. I**  
10x10 cm



**Spigolo Cod. E**  
10x10 cm

5x5 cm



10x10 cm



20x20 cm



20x40 cm



5x5 cm



10x10 cm



20x20 cm

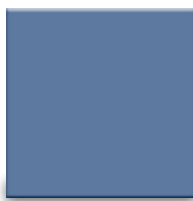

20x40 cm

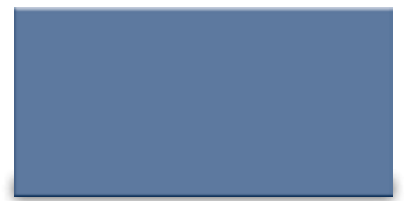

**Stick**  
1,2x20 cm



**Cod. M**  
2,5x20 cm



**Cod. N**  
2,5x20 cm



**Cod. W**  
2,5x10 cm



**Cod. K**  
2,5x10 cm



**Cod. E**  
2,5x2,5 cm



**Cod. F**  
2,5x2,5 cm

5x5 cm



10x10 cm



20x20 cm



20x40 cm



**Quadra**  
2,5x20 cm



**Stick**  
1,2x20 cm



**Cod. M**  
2,5x20 cm



**Cod. N**  
2,5x20 cm



**Cod. W**  
2,5x10 cm



**Cod. K**  
2,5x10 cm



**Cod. G**  
2,5x10 cm



**Cod. H**  
2,5x10 cm



**Cod. E**  
2,5x2,5 cm



**Cod. F**  
2,5x2,5 cm

P.E.I. ③

**IG**

P.E.I. ③

**RF**

P.E.I. ①

**TR**

P.E.I. ②

**IN**

10x20 cm

**Bisello**  
10x20 cm

5x20 cm

5x40 cm



**Cod. C**  
2,5x2,5 cm



**Cod. D**  
2,5x2,5 cm

10x20 cm

**Bisello**  
10x20 cm

5x20 cm

5x40 cm



**Cod. C**  
2,5x2,5 cm



**Cod. D**  
2,5x2,5 cm



**Cod. U**  
10x10 cm



**Cod. Z**  
10x10 cm



**Cod. X**  
10x20 cm



**Cod. I**  
10x20 cm

5x5 cm



10x10 cm



20x20 cm



20x40 cm



**Stick**  
1,2x20 cm



**Cod. M**  
2,5x20 cm



**Cod. N**  
2,5x20 cm



**Cod. W**  
2,5x10 cm



**Cod. K**  
2,5x10 cm



**Cod. E**  
2,5x2,5 cm



**Cod. F**  
2,5x2,5 cm

5x5 cm



10x10 cm



20x20 cm



20x40 cm



**Quadra**  
2,5x20 cm



**Stick**  
1,2x20 cm



**Cod. M**  
2,5x20 cm



**Cod. N**  
2,5x20 cm



**Cod. W**  
2,5x10 cm



**Cod. K**  
2,5x10 cm



**Cod. G**  
2,5x10 cm



**Cod. H**  
2,5x10 cm



**Cod. E**  
2,5x2,5 cm



**Cod. F**  
2,5x2,5 cm

**IG**

**RF**

**TR**

**IN**

10x20 cm



5x20 cm



5x40 cm



P.E.I. ②

  
**Cod. C**  
2,5x2,5 cm

  
**Cod. D**  
2,5x2,5 cm

10x20 cm



5x20 cm



5x40 cm



P.E.I. ②

  
**Cod. C**  
2,5x2,5 cm

  
**Cod. D**  
2,5x2,5 cm

  
**Cod. U**  
10x10 cm

  
**Cod. Z**  
10x10 cm

  
**Cod. X**  
10x20 cm

  
**Cod. I**  
10x20 cm

5x5 cm



10x10 cm



20x20 cm



**Bordo Cod. B**  
10x10 cm



**Angolo Cod. I**  
10x10 cm



**Spigolo Cod. E**  
10x10 cm

5x5 cm



10x10 cm



20x20 cm



20x40 cm



5x5 cm



10x10 cm



**Bisello**  
10x10 cm



20x20 cm



20x40 cm



**Stick**  
1,2x20 cm



**Cod. M**  
2,5x20 cm



**Cod. N**  
2,5x20 cm



**Cod. W**  
2,5x10 cm



**Cod. K**  
2,5x10 cm



**Cod. E**  
2,5x2,5 cm



**Cod. F**  
2,5x2,5 cm

5x5 cm



10x10 cm



20x20 cm



20x40 cm



**Quadra**  
2,5x20 cm



**Stick**  
1,2x20 cm



**Cod. M**  
2,5x20 cm



**Cod. N**  
2,5x20 cm



**Cod. W**  
2,5x10 cm



**Cod. K**  
2,5x10 cm



**Cod. G**  
2,5x10 cm



**Cod. H**  
2,5x10 cm



**Cod. E**  
2,5x2,5 cm



**Cod. F**  
2,5x2,5 cm

P.E.I. ①

**IG**

P.E.I. ①

**RF**

P.E.I. ①

**TR**

P.E.I. ①

**IN**

10x20 cm

**Bisello**  
10x20 cm

5x20 cm

5x40 cm



  
**Cod. C**  
2,5x2,5 cm

  
**Cod. D**  
2,5x2,5 cm

10x20 cm

**Bisello**  
10x20 cm

5x20 cm

5x40 cm



  
**Cod. C**  
2,5x2,5 cm

  
**Cod. D**  
2,5x2,5 cm

  
**Cod. U**  
10x10 cm

  
**Cod. Z**  
10x10 cm

  
**Cod. X**  
10x20 cm

  
**Cod. I**  
10x20 cm

5x5 cm



10x10 cm



20x20 cm



20x40 cm



**Stick**  
1,2x20 cm



**Cod. M**  
2,5x20 cm



**Cod. N**  
2,5x20 cm



**Cod. W**  
2,5x10 cm



**Cod. K**  
2,5x10 cm



**Cod. E**  
2,5x2,5 cm



**Cod. F**  
2,5x2,5 cm

5x5 cm



10x10 cm



20x20 cm



20x40 cm



**Quadra**  
2,5x20 cm



**Stick**  
1,2x20 cm



**Cod. M**  
2,5x20 cm



**Cod. N**  
2,5x20 cm



**Cod. W**  
2,5x10 cm



**Cod. K**  
2,5x10 cm



**Cod. G**  
2,5x10 cm



**Cod. H**  
2,5x10 cm



**Cod. E**  
2,5x2,5 cm



**Cod. F**  
2,5x2,5 cm



IG

RF

TR

IN

10x20 cm

**Bisello**  
10x20 cm

5x20 cm

5x40 cm

P.E.I. ①



  
**Cod. C**  
2,5x2,5 cm

  
**Cod. D**  
2,5x2,5 cm

10x20 cm

**Bisello**  
10x20 cm

5x20 cm

5x40 cm

P.E.I. ②

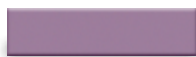

  
**Cod. C**  
2,5x2,5 cm

  
**Cod. D**  
2,5x2,5 cm

  
**Cod. U**  
10x10 cm

  
**Cod. Z**  
10x10 cm

  
**Cod. X**  
10x20 cm

  
**Cod. I**  
10x20 cm

5x5 cm



10x10 cm



20x20 cm



20x40 cm

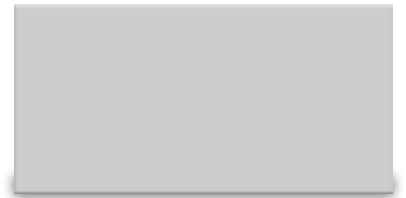

**Stick**  
1,2x20 cm



**Cod. M**  
2,5x20 cm



**Cod. N**  
2,5x20 cm



**Cod. W**  
2,5x10 cm



**Cod. K**  
2,5x10 cm



**Cod. E**  
2,5x2,5 cm



**Cod. F**  
2,5x2,5 cm

5x5 cm



10x10 cm



20x20 cm



20x40 cm



**Quadra**  
2,5x20 cm



**Stick**  
1,2x20 cm



**Cod. M**  
2,5x20 cm



**Cod. N**  
2,5x20 cm



**Cod. W**  
2,5x10 cm



**Cod. K**  
2,5x10 cm



**Cod. G**  
2,5x10 cm



**Cod. H**  
2,5x10 cm



**Cod. E**  
2,5x2,5 cm



**Cod. F**  
2,5x2,5 cm

**IG**

**RF**

**TR**

**IN**

10x20 cm

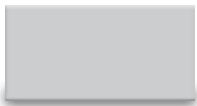

5x20 cm



5x40 cm



P.E.I. ③



**Cod. C**  
2,5x2,5 cm



**Cod. D**  
2,5x2,5 cm

10x20 cm



5x20 cm



5x40 cm



P.E.I. ④



**Cod. C**  
2,5x2,5 cm



**Cod. D**  
2,5x2,5 cm



**Cod. U**  
10x10 cm



**Cod. Z**  
10x10 cm



**Cod. X**  
10x20 cm



**Cod. I**  
10x20 cm

5x5 cm



10x10 cm



20x20 cm



**Bordo Cod. B**  
10x10 cm



**Angolo Cod. I**  
10x10 cm



**Spigolo Cod. E**  
10x10 cm

5x5 cm



10x10 cm



20x20 cm



20x40 cm



5x5 cm



10x10 cm



20x20 cm



20x40 cm



**Stick**  
1,2x20 cm



**Cod. M**  
2,5x20 cm



**Cod. N**  
2,5x20 cm



**Cod. W**  
2,5x10 cm



**Cod. K**  
2,5x10 cm



**Cod. E**  
2,5x2,5 cm



**Cod. F**  
2,5x2,5 cm

5x5 cm



10x10 cm



20x20 cm

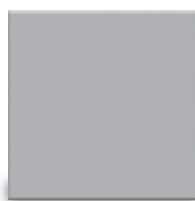

20x40 cm

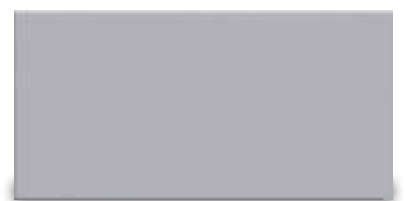

**Quadra**  
2,5x20 cm



**Stick**  
1,2x20 cm



**Cod. M**  
2,5x20 cm



**Cod. N**  
2,5x20 cm



**Cod. W**  
2,5x10 cm



**Cod. K**  
2,5x10 cm



**Cod. G**  
2,5x10 cm



**Cod. H**  
2,5x10 cm



**Cod. E**  
2,5x2,5 cm



**Cod. F**  
2,5x2,5 cm

P.E.I. ④

IG

P.E.I. ④

RF

P.E.I. ③

TR

P.E.I. ④

IN

10x20 cm



5x20 cm



5x40 cm



**Cod. C**  
2,5x2,5 cm



**Cod. D**  
2,5x2,5 cm

10x20 cm



5x20 cm



5x40 cm



**Cod. C**  
2,5x2,5 cm



**Cod. D**  
2,5x2,5 cm



**Cod. U**  
10x10 cm



**Cod. Z**  
10x10 cm



**Cod. X**  
10x20 cm



**Cod. I**  
10x20 cm

5x5 cm



10x10 cm



20x20 cm

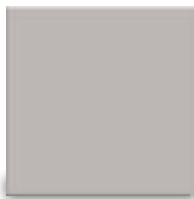

20x40 cm

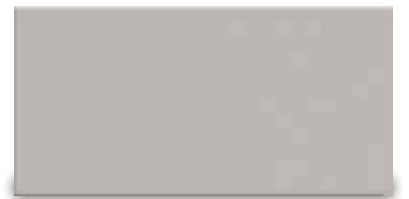

**Quadra**  
2,5x20 cm



**Stick**  
1,2x20 cm



**Cod. M**  
2,5x20 cm



**Cod. N**  
2,5x20 cm



**Cod. W**  
2,5x10 cm



**Cod. K**  
2,5x10 cm



**Cod. G**  
2,5x10 cm



**Cod. H**  
2,5x10 cm



**Cod. E**  
2,5x2,5 cm



**Cod. F**  
2,5x2,5 cm

IG

RF

TR

**Bisello**  
10x20 cm



10x20 cm

**Bisello**  
10x20 cm



5x20 cm



5x40 cm



P.E.I. ③

IN

**Cod. C**  
2,5x2,5 cm



**Cod. D**  
2,5x2,5 cm



**Cod. U**  
10x10 cm



**Cod. Z**  
10x10 cm



**Cod. X**  
10x20 cm



**Cod. I**  
10x20 cm



5x5 cm



10x10 cm



20x20 cm

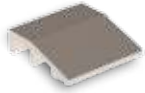

**Bordo Cod. B**  
10x10 cm



**Angolo Cod. I**  
10x10 cm



**Spigolo Cod. E**  
10x10 cm

5x5 cm



10x10 cm



20x20 cm



20x40 cm



5x5 cm



10x10 cm



20x20 cm



20x40 cm



**Stick**  
1,2x20 cm



**Cod. M**  
2,5x20 cm



**Cod. N**  
2,5x20 cm



**Cod. W**  
2,5x10 cm



**Cod. K**  
2,5x10 cm



**Cod. E**  
2,5x2,5 cm



**Cod. F**  
2,5x2,5 cm

5x5 cm



10x10 cm



20x20 cm

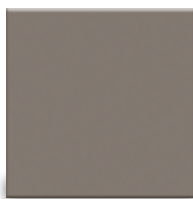

20x40 cm

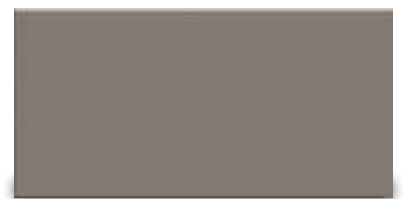

**Quadra**  
2,5x20 cm



**Stick**  
1,2x20 cm



**Cod. M**  
2,5x20 cm



**Cod. N**  
2,5x20 cm



**Cod. W**  
2,5x10 cm



**Cod. K**  
2,5x10 cm



**Cod. G**  
2,5x10 cm



**Cod. H**  
2,5x10 cm



**Cod. E**  
2,5x2,5 cm



**Cod. F**  
2,5x2,5 cm



P.E.I. ③

IG

P.E.I. ③

RF

P.E.I. ①

TR

P.E.I. ②

IN

10x20 cm

**Bisello**  
10x20 cm

5x20 cm

5x40 cm



**Cod. C**  
2,5x2,5 cm



**Cod. D**  
2,5x2,5 cm

10x20 cm

**Bisello**  
10x20 cm

5x20 cm

5x40 cm

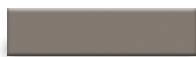

**Cod. C**  
2,5x2,5 cm



**Cod. D**  
2,5x2,5 cm



**Cod. U**  
10x10 cm



**Cod. Z**  
10x10 cm



**Cod. X**  
10x20 cm



**Cod. I**  
10x20 cm

5x5 cm



10x10 cm



20x20 cm



20x40 cm



**Stick**  
1,2x20 cm



**Cod. M**  
2,5x20 cm



**Cod. N**  
2,5x20 cm



**Cod. W**  
2,5x10 cm



**Cod. K**  
2,5x10 cm



**Cod. E**  
2,5x2,5 cm



**Cod. F**  
2,5x2,5 cm

5x5 cm



10x10 cm



20x20 cm



20x40 cm



**Quadra**  
2,5x20 cm



**Stick**  
1,2x20 cm



**Cod. M**  
2,5x20 cm



**Cod. N**  
2,5x20 cm



**Cod. W**  
2,5x10 cm



**Cod. K**  
2,5x10 cm



**Cod. G**  
2,5x10 cm



**Cod. H**  
2,5x10 cm



**Cod. E**  
2,5x2,5 cm



**Cod. F**  
2,5x2,5 cm

IG

RF

TR

IN

10x20 cm



5x20 cm



5x40 cm



P.E.I. ①

  
**Cod. C**  
2,5x2,5 cm

  
**Cod. D**  
2,5x2,5 cm

10x20 cm



5x20 cm



5x40 cm



P.E.I. ②

  
**Cod. C**  
2,5x2,5 cm

  
**Cod. D**  
2,5x2,5 cm

  
**Cod. U**  
10x10 cm

  
**Cod. Z**  
10x10 cm

  
**Cod. X**  
10x20 cm

  
**Cod. I**  
10x20 cm

5x5 cm



10x10 cm



20x20 cm



**Bordo Cod. B**  
10x10 cm



**Angolo Cod. I**  
10x10 cm



**Spigolo Cod. E**  
10x10 cm

5x5 cm



10x10 cm



20x20 cm



20x40 cm



5x5 cm



10x10 cm



**Bisello**  
10x10 cm



20x20 cm



20x40 cm

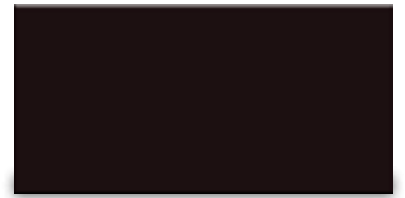

**Stick**  
1,2x20 cm



**Cod. M**  
2,5x20 cm



**Cod. N**  
2,5x20 cm



**Cod. W**  
2,5x10 cm



**Cod. K**  
2,5x10 cm



**Cod. E**  
2,5x2,5 cm



**Cod. F**  
2,5x2,5 cm

5x5 cm



10x10 cm



20x20 cm



20x40 cm



**Quadra**  
2,5x20 cm



**Stick**  
1,2x20 cm



**Cod. M**  
2,5x20 cm



**Cod. N**  
2,5x20 cm



**Cod. W**  
2,5x10 cm



**Cod. K**  
2,5x10 cm



**Cod. G**  
2,5x10 cm



**Cod. H**  
2,5x10 cm



**Cod. E**  
2,5x2,5 cm



**Cod. F**  
2,5x2,5 cm

P.E.I. ①

**IG**

P.E.I. ①

**RF**

P.E.I. ①

**TR**

P.E.I. ①

**IN**

10x20 cm

**Bisello**  
10x20 cm

5x20 cm

5x40 cm



**Cod. C**  
2,5x2,5 cm



**Cod. D**  
2,5x2,5 cm

10x20 cm

**Bisello**  
10x20 cm

5x20 cm

5x40 cm



**Cod. C**  
2,5x2,5 cm



**Cod. D**  
2,5x2,5 cm



**Cod. U**  
10x10 cm



**Cod. Z**  
10x10 cm



**Cod. X**  
10x20 cm



**Cod. I**  
10x20 cm

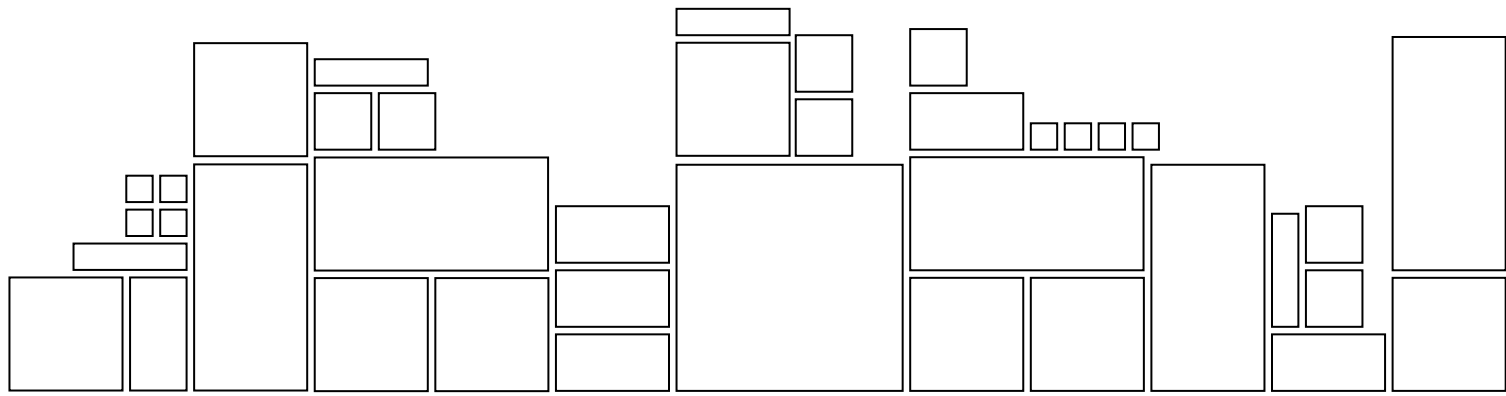

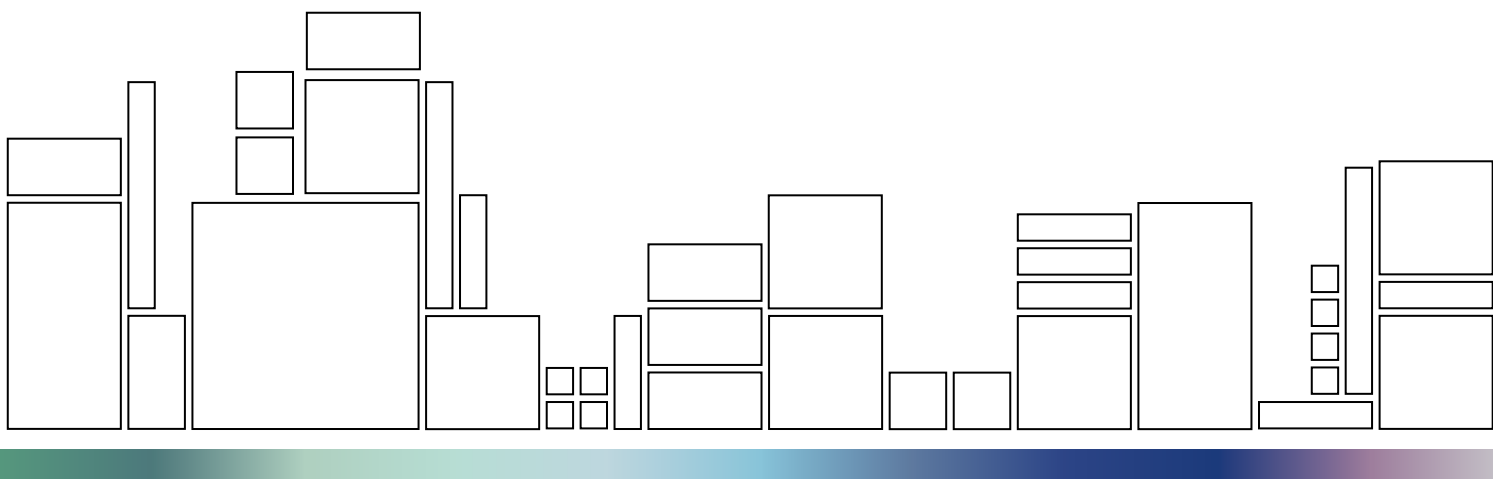

# VOGUE Link

Interni Mix

Trasparenze Mix

Flooring Mix R10 B (A+B)

Grip Mix R11 C (A+B+C)

## Cos'è Vogue Link

La collezione Vogue Link raggruppa prodotti che sono derivati dal Vogue System e con esso si integrano per formati e finiture. Pensata per soluzioni decorative sia in ambito residenziale che pubblico, ideale per pavimenti e rivestimenti in base alle caratteristiche della superficie utilizzata. Le molteplici proposte cromatiche offrono soluzioni progettuali in grado di rendere unico ogni ambiente.

## Qué es Vogue Link

La colección Vogue Link reúne productos que derivan del Vogue System y sus formatos y acabados se integran en el mismo. Pensado para soluciones decorativas tanto en ámbito residencial como público, ideal para suelos y revestimientos en base a las características de la superficie utilizada. Las múltiples propuestas cromáticas ofrecen soluciones de diseño capaces de dar unicidad a un espacio.

## Что такое Vogue Link

В серию Vogue Link входит сопутствующая продукция, сочетающаяся по форматам и видам поверхностей с Vogue System. Данная линия разработана для декоративной отделки как частных, так и общественных зон, она идеальна для применения в качестве напольных покрытий и облицовки в зависимости от используемого вида плитки. Цветовое многообразие позволяет создавать различные варианты отделки, придающие уникальный облик любому помещению.

## 什么是Vogue Link

Vogue Link系列将衍生于Vogue System的产品组合在一起,包括不同的尺寸和饰面。这是一种即适用于住宅也应用于公共场所的装饰解决方案,可根据地板和墙面的不同使用特性选择理想的饰面。通过多种色彩的产品所提供的设计解决方案,可使每一种环境都独具特色。



## Interni Mix - trasparenze Mix - Flooring Mix R10 B (A+B) - Grip Mix R11 C (A+B+C)

Nell'ambito del programma Vogue Link , nascono le serie di miscele Interni Mix, trasparenze Mix, Flooring Mix e Grip Mix; nuove soluzioni decorative da abbinare all'ampia gamma di colori e formati di Vogue System. Le miscele in grès smaltato in pasta bianca, ingelivo, nel formato cm 5x5, grazie alle 52 sfumature di colore proposte nella finitura satinata, lucida e antiscivolo, sono pensate per fornire ampie possibilità progettuali e fantasiose alternative alla tinta unita. Adatte per pavimenti e rivestimenti, interni ed esterni, nel formato cm 5x5 assemblato su rete in fibra di vetro, f.to finito cm 30x30.

En el ámbito del programa Vogue Link, nacen las series de mezclas Interni Mix, trasparenze Mix, Flooring Mix y Grip Mix; nuevas soluciones decorativas para combinar con la amplia gama de colores y formatos de Vogue System.

Las mezclas en gres esmaltado en pasta blanca, anti hielo, en el formato 5x5 cm, gracias a los 52 matices de color propuestos para el acabado satinado, brillante y antideslizante, han sido creadas para ofrecer amplias posibilidades proyectuales y fantasiosas alternativas al color uniforme.

Adecuadas para pavimentos y revestimientos interiores y exteriores, en el formato de 5x5 cm ensamblado sobre malla de fibra de vidrio; formato acabado 30x30 cm.

В рамках программы Vogue Link предлагаются серий смешанных композиций Interni Mix, trasparenze Mix, Flooring Mix и Grip Mix, которые представляют собой новые декоративные решения, дополняющие широкую гамму расцветок и форматов линии Vogue System.

Смеси из морозоустойчивого эмалированного керамогранита из белой глины размером 5x5, представленные в 52 оттенках с матовым, глянцевым или противоскользящим покрытием предоставляют обширные проектировочные возможности и причудливые альтернативы монохромным цветам.

Данная плитка пригодна для облицовки полов и стен в помещениях и наружных зонах, она выпускается в формате 5x5 см и монтируется на стекловолоконную сетку, размер готовой секции - 30x30 см.

在Vogue Link计划范围内,产生出下述混合产品系列:内部混合,透明混合,地板混合,防滑混合;它们是可与具有广泛色彩及造型选择的Vogue System产品进行配套的新装饰性解决方案。

防冻玻璃釉面陶瓷砖和炻瓷砖混合物,采用5x5厘米的造型,在亚光、抛光和防滑饰面中提供52种色调变化,旨在提供广泛设计可能性及作为单色调的丰富多彩的替代品,适合于地面和墙面,室内和室外,将5x5厘米的造型组装在玻璃纤维网上,形成30x30厘米的混合模块。

**Interni Mix** *superficie satinata* *superficie satinada* *сатинованная* 亞光施釉

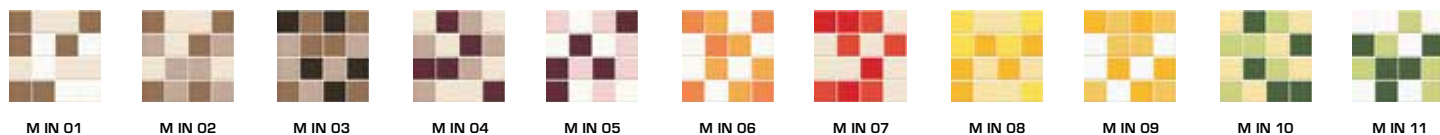

M IN 01 M IN 02 M IN 03 M IN 04 M IN 05 M IN 06 M IN 07 M IN 08 M IN 09 M IN 10 M IN 11

Utilizzo: interni ed esterni, pavimenti e rivestimenti  
 Uso: interiores y exteriores, pavimentos y revestimientos  
 Использование: внутренняя и наружная отделка, полы и облицовка  
 使用: 室內和室外, 牆地兩用磚

Formati 30x30 (5x5)  
 Formatos 12"x12" (2"x2")  
 Форматы 尺寸 } ≙ 0,7 cm

montato su rete in fibra di vetro  
 compuesto por red de fibra de vidrio  
 монтирован на сетке из стекловолоконна  
 安装在玻璃纤维

**Trasparenze Mix** *superficie antiscivolo satinata* *superficie brillante* *Глянцевая поверхность* 亮光表面

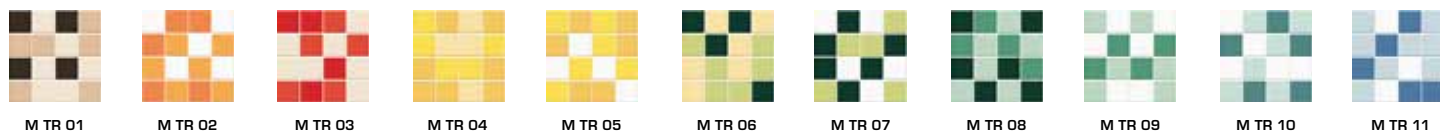

M TR 01 M TR 02 M TR 03 M TR 04 M TR 05 M TR 06 M TR 07 M TR 08 M TR 09 M TR 10 M TR 11

Utilizzo: interni ed esterni, rivestimento  
 Uso: interiores y exteriores, revestimientos  
 Использование: внутренняя и наружная отделка, облицовка  
 使用: 室內和室外, 牆面磚

Formati 30x30 (5x5)  
 Formatos 12"x12" (2"x2")  
 Форматы 尺寸 } ≙ 0,7 cm

montato su rete in fibra di vetro  
 compuesto por red de fibra de vidrio  
 монтирован на сетке из стекловолоконна  
 安装在玻璃纤维

**Flooring Mix R10 B (A+B) / Grip Mix R11 C (A+B+C)** *superficie antiscivolo satinata* *superficie*

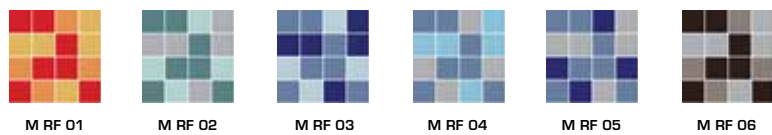

M RF 01 M RF 02 M RF 03 M RF 04 M RF 05 M RF 06

Utilizzo: interni ed esterni, pavimenti - R10 B (A+B)  
 Uso: interiores y exteriores, pavimentos - R10 B (A+B)  
 Использование: внутренняя и наружная отделка, полы) - R10 B (A+B)  
 使用: 室內和室外, 地面 - R10 B (A+B)

Formati 30x30 (5x5)  
 Formatos 12"x12" (2"x2")  
 Форматы 尺寸 } ≙ 0,7 cm

colori miscelati in modo casuale  
 colores mezclados en modo casual  
 цвета смешаны в произвольном порядке  
 顏色隨機混合

montato su rete in fibra di vetro  
 compuesto por red de fibra de vidrio  
 монтирован на сетке из стекловолоконна  
 安装在玻璃纤维

**M IN - Interni Mix**

**M TR - Trasparenze Mix**

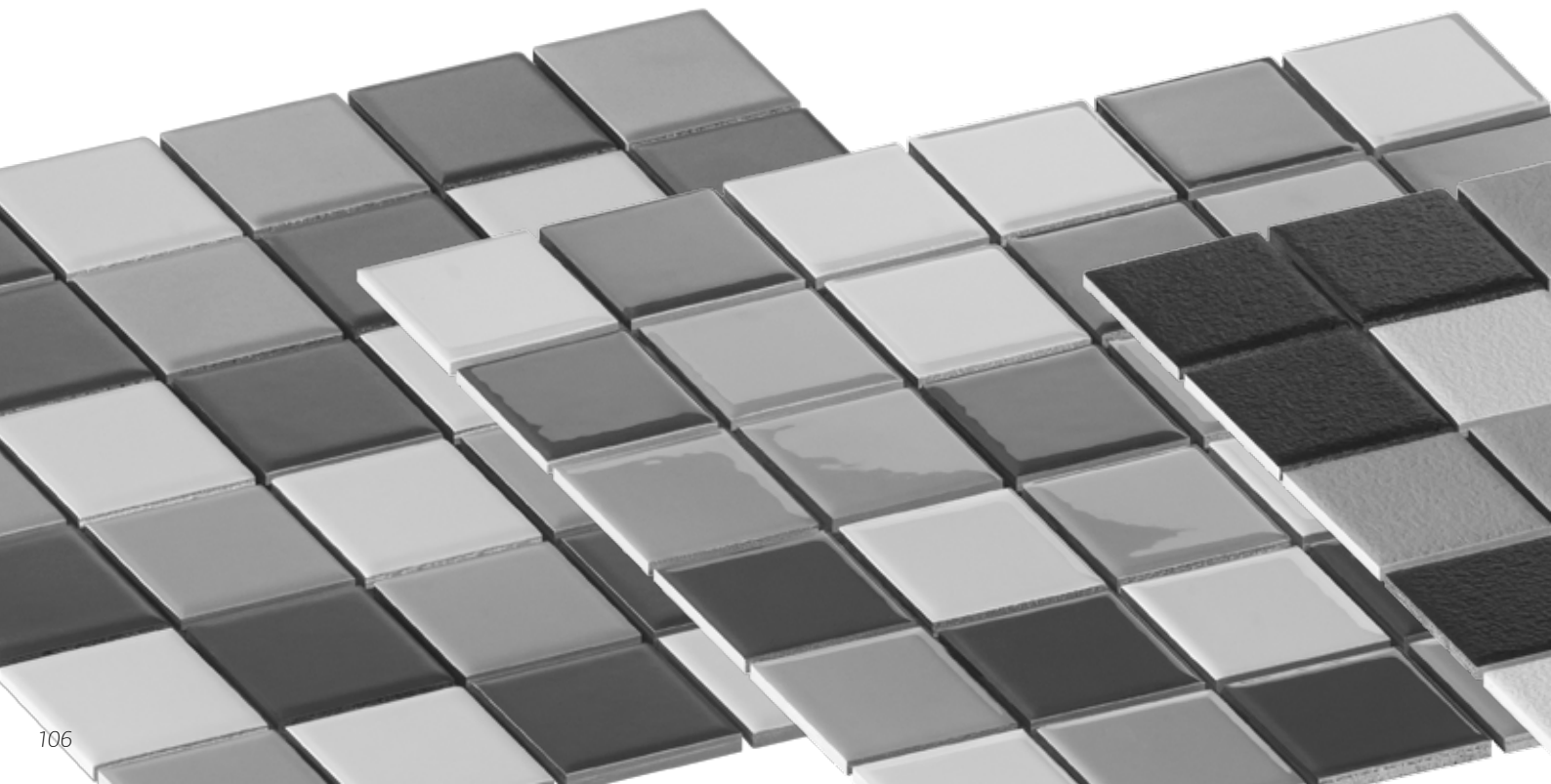



colori miscelati in modo casuale  
 colores mezclados en modo casual  
 цвета смешаны в произвольном порядке  
 顏色隨機混合



colori miscelati in modo casuale  
 colores mezclados en modo casual  
 цвета смешаны в произвольном порядке  
 顏色隨機混合

**antideslizante satinada противоскользящая сатирированная поверхность 亞光施釉防滑表面**

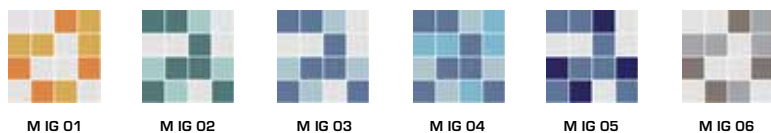

colori miscelati in modo casuale  
 colores mezclados en modo casual  
 цвета смешаны в произвольном порядке  
 顏色隨機混合

Utilizzo: interni ed esterni, pavimenti - R 11 C (A+B+C)  
 Uso: interiores y exteriores, pavimentos - R11 C (A+B+C)  
 Использование: внутренняя и наружная отделка, полы) - R11 C (A+B+C)  
 使用: 室內和室外, 地面 - R11 C (A+B+C)

Formati  
 Formatos  
 Форматы  
 尺寸

30x30  
 (5x5)  
 12"x12"  
 (2'x2')

0,7 cm

montato su rete in fibra di vetro  
 compuesto por red de fibra de vidrio  
 монтирован на сетке из стекловолоконна  
 安装在玻璃纤维

**M RF - Flooring Mix R10 B (A+B)**

**M IG - Grip Mix R11 C (A+B+C)**

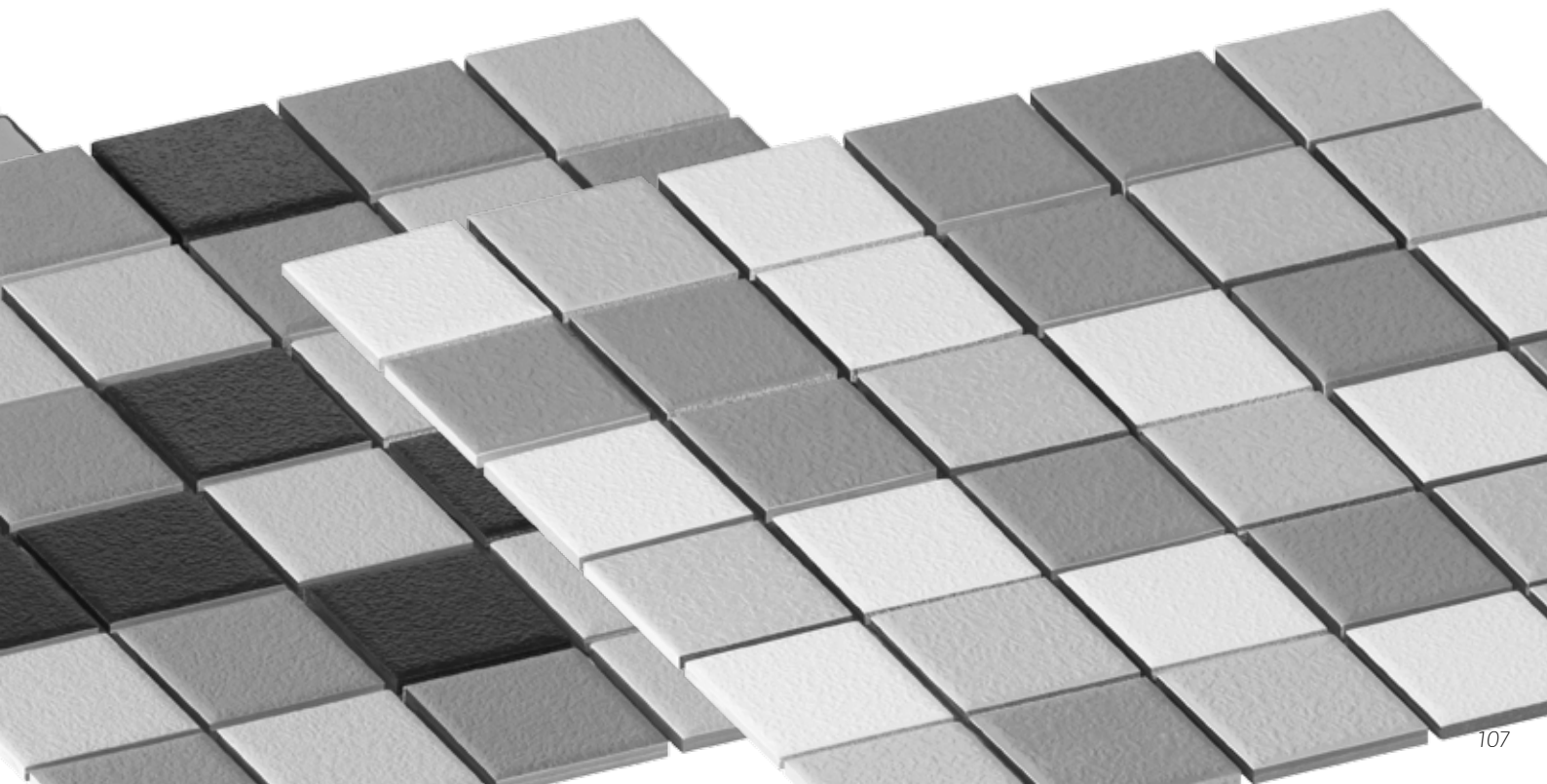

M IN 01

IN latte 33%  
 IN seta 33%  
 IN nocciola 33%



30x30 cm

M IN 02

IN seta 33%  
 IN tortora 33%  
 IN nocciola 33%



30x30 cm

M IN 03

IN nocciola 33%  
 IN tortora 33%  
 IN caffè 33%



30x30 cm

M IN 04

IN seta 33%  
 IN tortora 33%  
 IN bordeaux 33%

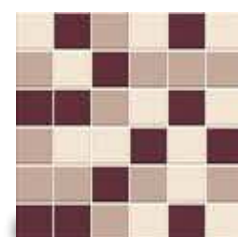

30x30 cm

M IN 05

IN latte 33%  
 IN rosa 33%  
 IN bordeaux 33%

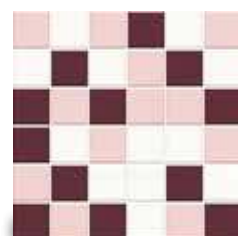

30x30 cm

M IN 06

IN latte 33%  
 IN papaya 33%  
 IN mandarino 33%

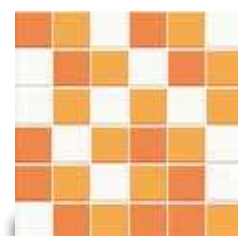

30x30 cm

M IN 07

IN seta 33%  
 IN rosso 33%  
 IN corallo 33%



30x30 cm

M IN 08

IN girasole 33%  
 IN cedro 33%  
 IN pompelmo 33%

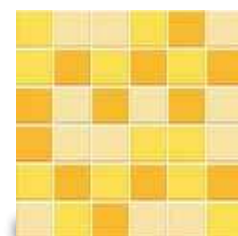

30x30 cm

M IN 09

IN ghiaccio 33%  
 IN girasole 33%  
 IN giallo 33%

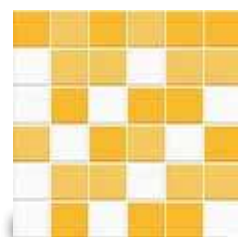

30x30 cm

M IN 10

IN pompelmo 33%  
 IN pistacchio 33%  
 IN oliva 33%

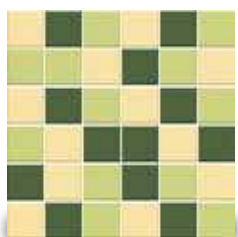

30x30 cm

M IN 11

IN ghiaccio 33%  
 IN pistacchio 33%  
 IN oliva 33%

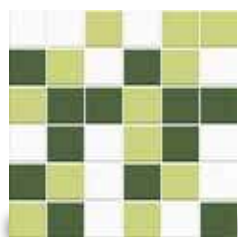

30x30 cm

M IN 12

IN pistacchio 33%  
 IN oliva 33%  
 IN menta 33%



30x30 cm

M IN 13

IN menta 33%  
 IN smeraldo 33%  
 IN giada 33%

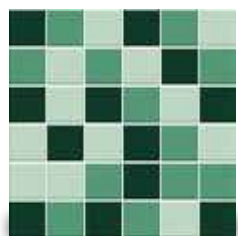

30x30 cm

M IN 14

IN latte 33%  
 IN smeraldo 33%  
 IN giada 33%

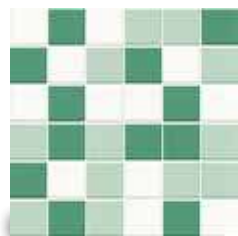

30x30 cm

M IN 15

IN ghiaccio 33%  
 IN turchese 33%  
 IN laguna 33%

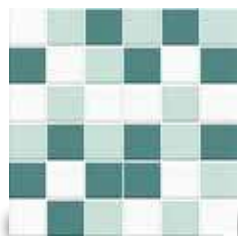

30x30 cm

M IN 16

IN ghiaccio 33%  
 IN azzurro 33%  
 IN blu avio 33%

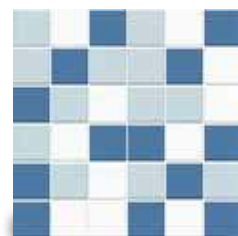

30x30 cm

M IN 17

IN blu avio 33%  
 IN oltremare 33%  
 IN lilla 33%



30x30 cm

M IN 18

IN lavanda 33%  
 IN lilla 33%  
 IN perla 33%

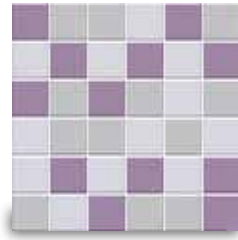

30x30 cm

M IN 19

IN ghiaccio 33%  
 IN argento 33%  
 IN grigio 33%



30x30 cm

M IN 20

IN argento 33%  
 IN grigio 33%  
 IN ferro 33%



30x30 cm

M IN 21

IN grigio 33%  
 IN ferro 33%  
 IN nero 33%



30x30 cm

S IN 01

IN ghiaccio 50%  
 IN nero 50%

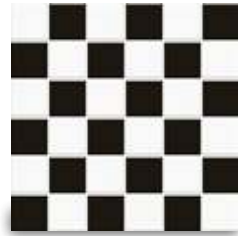

30x30 cm

Utilizzo: interni ed esterni, pavimenti e rivestimenti  
 Uso: interiores y exteriores, pavimentos y revestimientos  
 Использование: внутренняя и наружная отделка, полы и облицовка  
 使用: 室內和室外, 牆地兩用磚

Formati  
 Formatos  
 Форматы  
 尺寸

30x30  
 (5x5)  
 12"x12"  
 (2'x2')

0,7 cm

montato su rete in fibra di vetro  
 compuesto por red de fibra de vidrio  
 монтирован на сетке из стекловолокна  
 安装在玻璃纤维

colori miscelati in modo casuale  
 colores mezclados en modo casual  
 цвета смешаны в произвольном порядке  
 顏色隨機混合



**M TR 01**

TR seta 33%  
TR beige 33%  
TR caffè 33%



30x30 cm

**M TR 02**

TR ghiaccio 33%  
TR papaya 33%  
TR mandarino 33%

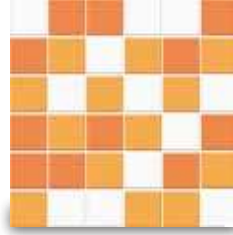

30x30 cm

**M TR 03**

TR seta 33%  
TR rosso 33%  
TR corallo 33%



30x30 cm

**M TR 04**

TR giallo 33%  
TR cedro 33%  
TR pompelmo 33%

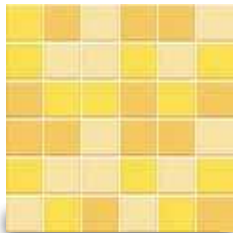

30x30 cm

**M TR 05**

TR ghiaccio 33%  
TR giallo 33%  
TR cedro 33%

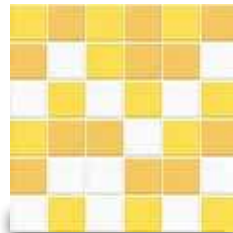

30x30 cm

**M TR 06**

TR pompelmo 33%  
TR pistacchio 33%  
TR menta 33%

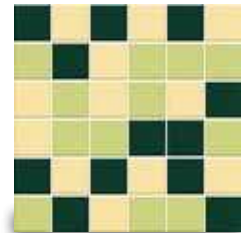

30x30 cm

**M TR 07**

TR ghiaccio 33%  
TR pistacchio 33%  
TR menta 33%

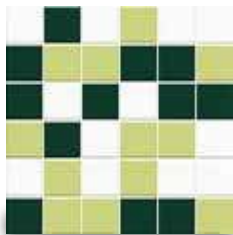

30x30 cm

**M TR 08**

TR menta 33%  
TR smeraldo 33%  
TR giada 33%

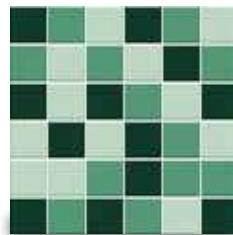

30x30 cm

**M TR 09**

TR ghiaccio 33%  
TR smeraldo 33%  
TR giada 33%

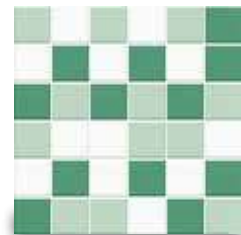

30x30 cm

**M TR 10**

TR ghiaccio 33%  
TR turchese 33%  
TR laguna 33%

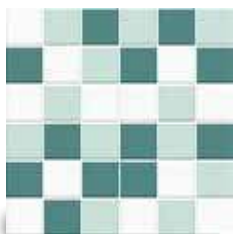

30x30 cm

**M TR 11**

TR ghiaccio 33%  
TR azzurro 33%  
TR blu avio 33%

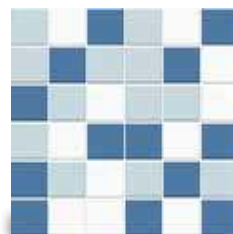

30x30 cm

**M TR 12**

TR azzurro 33%  
TR cielo 33%  
TR blu avio 33%

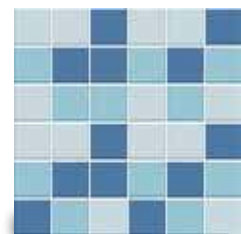

30x30 cm

**M TR 13**

TR blu avio 33%  
TR oltremare 33%  
TR lilla 33%



30x30 cm

**M TR 14**

TR blu avio 33%  
TR lilla 33%  
TR perla 33%

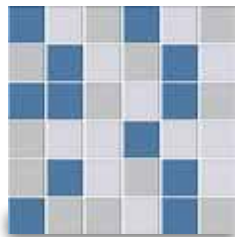

30x30 cm

**M TR 15**

TR lavanda 33%  
TR lilla 33%  
TR perla 33%

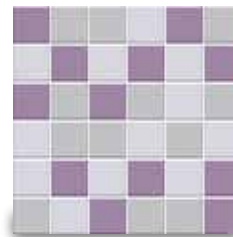

30x30 cm

**M TR 16**

TR perla 33%  
TR grigio 33%  
TR ferro 33%



30x30 cm

**M TR 17**

TR grigio 33%  
TR ferro 33%  
TR nero 33%



30x30 cm

**S TR 01**

TR ghiaccio 50%  
TR nero 50%

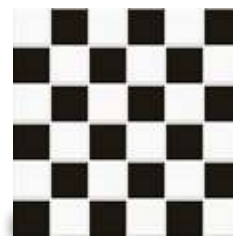

30x30 cm

Utilizzo: interni ed esterni, rivestimento  
Uso: interiores y exteriores, revestimientos  
Использование: внутренняя и наружная отделка, облицовка  
使用: 室內和室外, 牆面磚

Formati  
Formatos  
Форматы  
尺寸

30x30  
(5x5)  
12"x12"  
(2'x2') } 0,7 cm

montato su rete in fibra di vetro  
compuesto por red de fibra de vidrio  
монтирован на сетке из стекловолокна  
安裝在玻璃纖維

colori miscelati in modo casuale  
colores mezclados en modo casual  
цвета смешаны в произвольном порядке  
顏色隨機混合

**M RF 01**

RF mandarino 33%  
RF giallo 33%  
RF rosso 33%

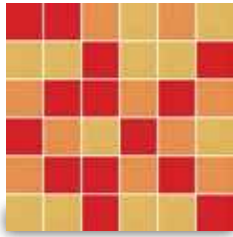

30x30 cm

**M RF 02**

RF turchese 33%  
RF laguna 33%  
RF perla 33%



30x30 cm

**M RF 03**

RF azzurro 33%  
RF blu avio 33%  
RF cobalto 33%

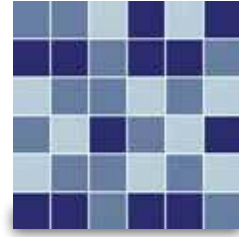

30x30 cm

**M RF 04**

RF cielo 33%  
RF blu avio 33%  
RF perla 33%

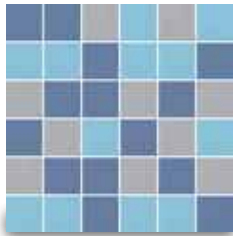

30x30 cm

**M RF 05**

RF blu avio 33%  
RF cobalto 33%  
RF perla 33%

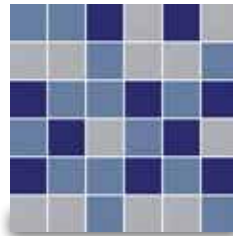

30x30 cm

**M RF 06**

RF perla 33%  
RF grigio 33%  
RF nero 33%



30x30 cm

Utilizzo: interni ed esterni, pavimenti - R10 B (A+B)  
Uso: interiores y exteriores, pavimentos - R10 B (A+B)  
Использование: внутренняя и наружная отделка, полы) - R10 B (A+B)  
使用: 室内和室外, 地面 - R10 B (A+B)

Formati  
Formatos  
Форматы  
尺寸

30x30  
(5x5)  
12"x12"  
(2"x2")

0,7 cm

montato su rete in fibra di vetro  
compuesto por red de fibra de vidrio  
монтирован на сетке из стекловолоконна  
安装在玻璃纤维

colori miscelati in modo casuale  
colores mezclados en modo casual  
цвета смешаны в произвольном порядке  
顏色隨機混合



## M IG 01

IG ghiaccio 33%  
 IG mandarino 33%  
 IG giallo 33%

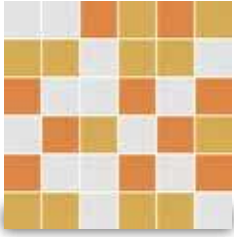

30x30 cm

## M IG 02

IG ghiaccio 33%  
 IG turchese 33%  
 IG laguna 33%

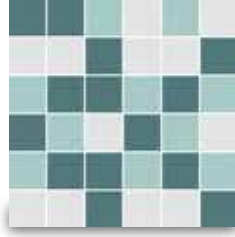

30x30 cm

## M IG 03

IG ghiaccio 33%  
 IG azzurro 33%  
 IG blu avio 33%

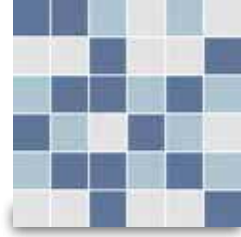

30x30 cm

## M IG 04

IG azzurro 33%  
 IG cielo 33%  
 IG blu avio 33%

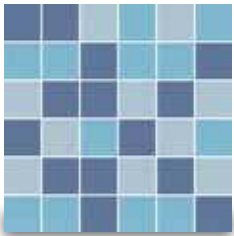

30x30 cm

## M IG 05

IG ghiaccio 33%  
 IG blu avio 33%  
 IG cobalto 33%

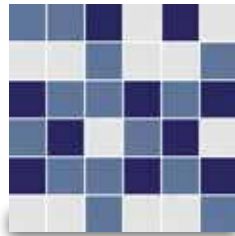

30x30 cm

## M IG 06

IG ghiaccio 33%  
 IG perla 33%  
 IG grigio 33%

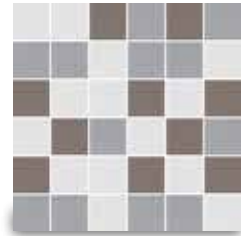

30x30 cm

Utilizzo: interni ed esterni, pavimenti - R 11 C (A+B+C)  
 Uso: interiores y exteriores, pavimentos - R11 C (A+B+C)  
 Использование: внутренняя и наружная отделка, полы) - R11 C (A+B+C)  
 使用: 室内和室外, 地面 - R11 C (A+B+C)

Formati  
 Formatos  
 Форматы  
 尺寸

30x30  
 (5x5)  
 12"x12"  
 (2'x2')

0,7 cm

montato su rete in fibra di vetro  
 compuesto por red de fibra de vidrio  
 монтирован на сетке из стекловолоконна  
 安装在玻璃纤维

colori miscelati in modo casuale  
 colores mezclados en modo casual  
 цвета смешаны в произвольном порядке  
 顏色隨機混合



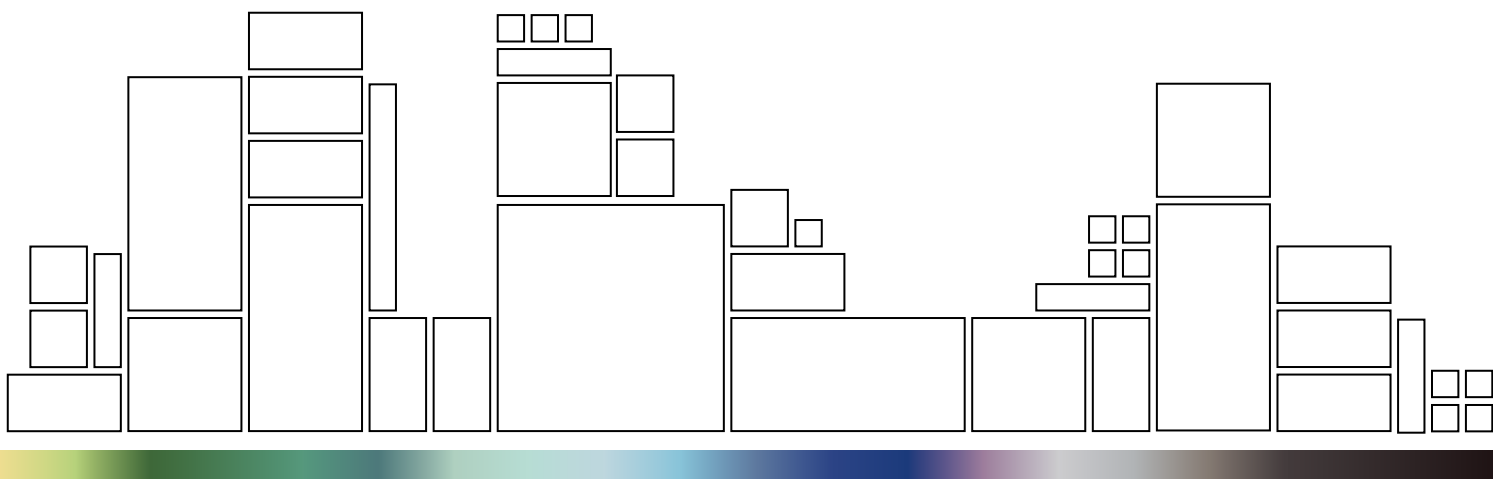

# VOGUE Floor

Interni40  
Flooring40 R10  
Grip40 B (A+B)

## Cos'è Vogue Floor

Vogue Floor raggruppa le serie Ceramica Vogue appositamente pensate per un uso a pavimento. Caratteristica comune alle serie è la capacità di coniugare un'estetica moderna ad alte prestazioni tecniche e di sicurezza, senza mai trascurare la necessità di garantire facilità di pulizia e di manutenzione. Praticità, funzionalità antiscivolo e originalità delle texture accomunano le linee Vogue Floor, tutte disponibili in una vasta gamma cromatica, adatte a ricoprire anche grandi superfici e utilizzabili in combinazione alle altre collezioni di Ceramica Vogue.

## Qué es Vogue Floor

Vogue Floor reúne la serie de Ceramica Vogue estudiada expresamente para su uso como pavimento. Una característica común de la serie es la capacidad de conjugar una estética moderna con altas prestaciones técnicas y de seguridad, sin dejar de lado la necesidad de garantizar facilidad de limpieza y de mantenimiento. Las línea Vogue Floor tienen en común la comodidad, la propiedad antideslizante y la originalidad de las texturas, todas disponibles en una dilatada gama de colores, adecuados para revestir también superficies grandes y utilizables en combinación con las otras colecciones de Ceramica Vogue.

## Что такое Vogue Floor

Vogue Floor объединяет разные серии напольной плитки Ceramica Vogue. Общие характеристики этой коллекции - это сочетание современной эстетики и высоких технических, безопасных свойств, сохраняя легкость уборки. Практичность, противоскольжения и своеобразие текстур обобщают все линии Vogue Floor. Они доступны в широкой цветовой гамме, сочетаются с другими коллекциями Ceramica Vogue и подходят для покрытия больших поверхностей.

## Floor 什么是 Vogue 地材

Vogue 地材集合了陶瓷 Vogue 專為地面使用所設計的系列。該系列所遵循一個共同的特性使得這個系列擁有用高技術性能滿足新穎設計的能力，同時保證安全並符合易於清洗和保養的要求。所有 Vogue 地材都是實用的，防滑的，保持了原始紋理，同時擁有豐富的顏色，備有大尺寸磚並可與陶瓷 Vogue 的其他系列搭配。

## Interni40

La superficie satinata e il grande formato per rivestire pavimentazioni elegantemente colorate. La gamma composta da 14 colori, derivati dal Vogue System, si presta anche ad un utilizzo a parete.

La superficie satinada y el formato grande para revestir pavimentos elegantemente coloreados. La gama se compone de 14 colores derivados del Vogue System y se presta también para el revestimiento de paredes.

Крупноформатное покрытие с матовой поверхностью для элегантной цветной отделки полов. Цветовая гамма состоит из 14 оттенков, соответствующих расцветкам Vogue System, эта плитка может также использоваться для облицовки стен.

亚光的表面及大块造型,使地板具有优雅的色彩。产品系列包括14种颜色,衍生于Vogue System,也适合墙面装饰。

## Flooring40 R10

Serie ideata con caratteristiche che coniugano l'aspetto estetico e quello tecnico antiscivolo (R10). Adatta per l'impiego in ambienti commerciali e residenziali.

Serie ideada con características que combinan la elegancia con las propiedades antideslizantes (R10). Adecuada para el empleo en ambientes comerciales y residenciales.

При разработке данной серии учитывались как эстетический аспект, так и техническое противоскользкое свойство (R10). Плитка пригодна для использования в помещениях коммерческого и жилого назначения.

这一系列突出了将审美外观与防滑技术相结合的特性 (R10)。适用于商业与住宅环境。

## Grip40 B (A+B)

Pensata per l'impiego a pavimento in zone con presenza di acqua. La caratteristica antiscivolo B (A+B) si presta in modo ottimale all'impiego nelle pavimentazioni circostanti le piscine.

Diseñada para emplear en pavimentos de zonas con agua. La característica antideslizante B (A+B) se presta para el empleo en los pavimentos alrededor de las piscinas.

Данная плитка предназначена для использования в мокрых зонах. Противоскользкая поверхность категории "B" (A+B) прекрасно подходит для мощения полов вокруг бассейнов.

专为使用在有水的区域而设计。B (A+B)产品的防滑特性,使它成为铺盖游泳池周围地面的最理想产品。

**Interni40** superficie satinata superficie satinada сатинованная поверхность 亞光施釉表面



Utilizzo: interni ed esterni, pavimenti e rivestimenti  
 Uso: interiores y exteriores, pavimentos y revestimientos  
 Использование: внутренняя и наружная отделка, полы и облицовка  
 使用: 室內和室外, 牆地兩用磚

Formati  
 Formatos 40x40 }  
 Форматы 16"x16" }  $\frac{\nabla}{\blacktriangle}$  0,85 cm  
 尺寸

**Flooring40 R10** superficie antiscivolo satinata Superficie antideslizante satinada противоскользкая сатинованная поверхность



Utilizzo: interni ed esterni, pavimenti - R10  
 Uso: interiores y exteriores, pavimentos - R10  
 Использование: внутренняя и наружная отделка, полы - R10  
 使用: 室內和室外, 地面 - R10

Formati  
 Formatos 40x40 }  
 Форматы 16"x16" }  $\frac{\nabla}{\blacktriangle}$  0,85 cm  
 尺寸

**Grip40 B (A+B)** superficie antiscivolo satinata Superficie antideslizante satinada противоскользкая сатинованная поверхность



Utilizzo: interni ed esterni, pavimenti - B (A+B)  
 Uso: interiores y exteriores, pavimentos - B (A+B)  
 Использование: внутренняя и наружная отделка, полы - B (A+B)  
 使用: 室內和室外, 地面 - B (A+B)

Formati  
 Formatos 40x40 }  
 Форматы 16"x16" }  $\frac{\nabla}{\blacktriangle}$  0,85 cm  
 尺寸

IN - Interni40

RF - Flooring40 R10

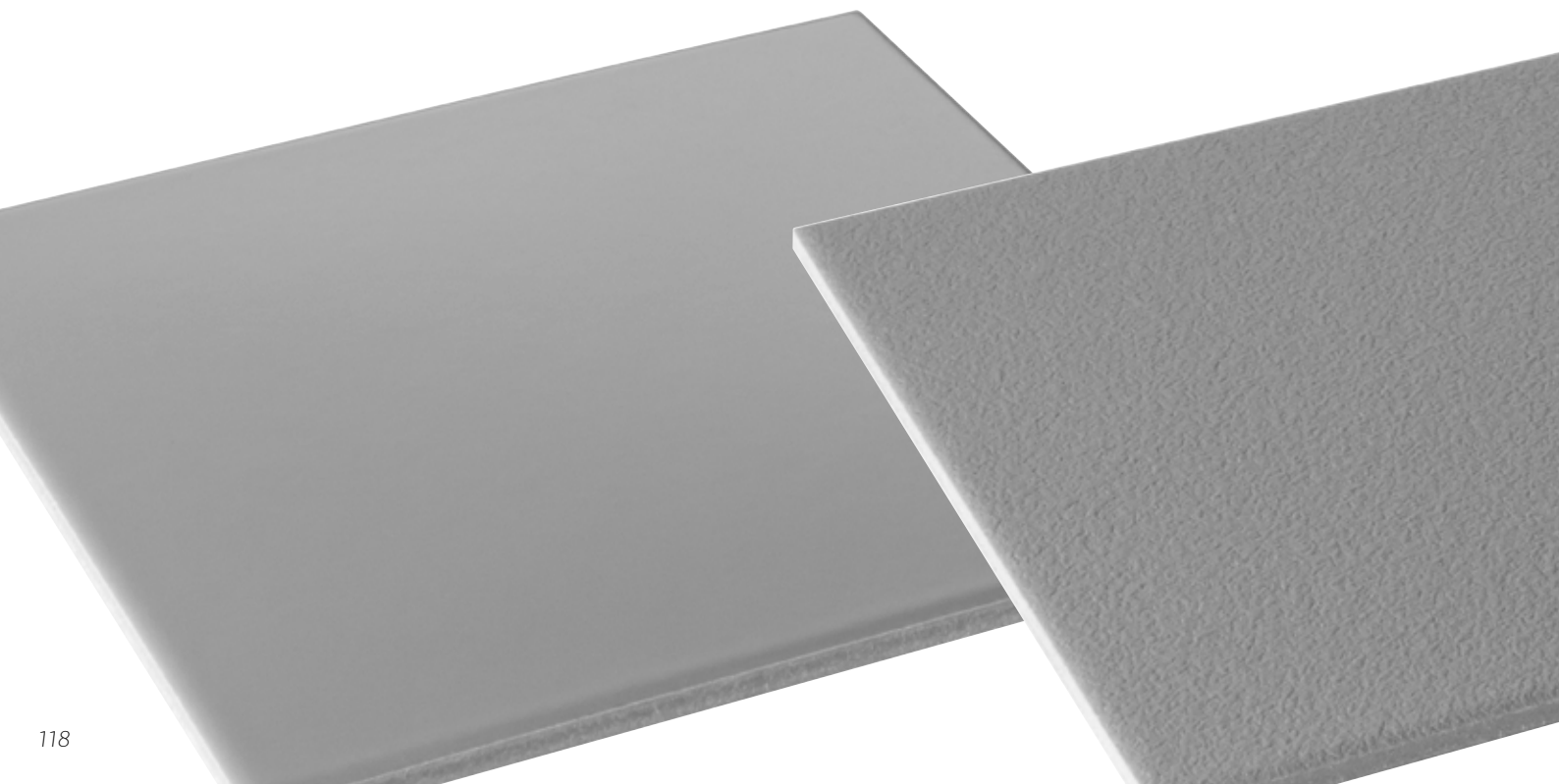



亞光施 釉防滑表面



亞光施 釉防滑表面

IG - Grip40 B (A+B)

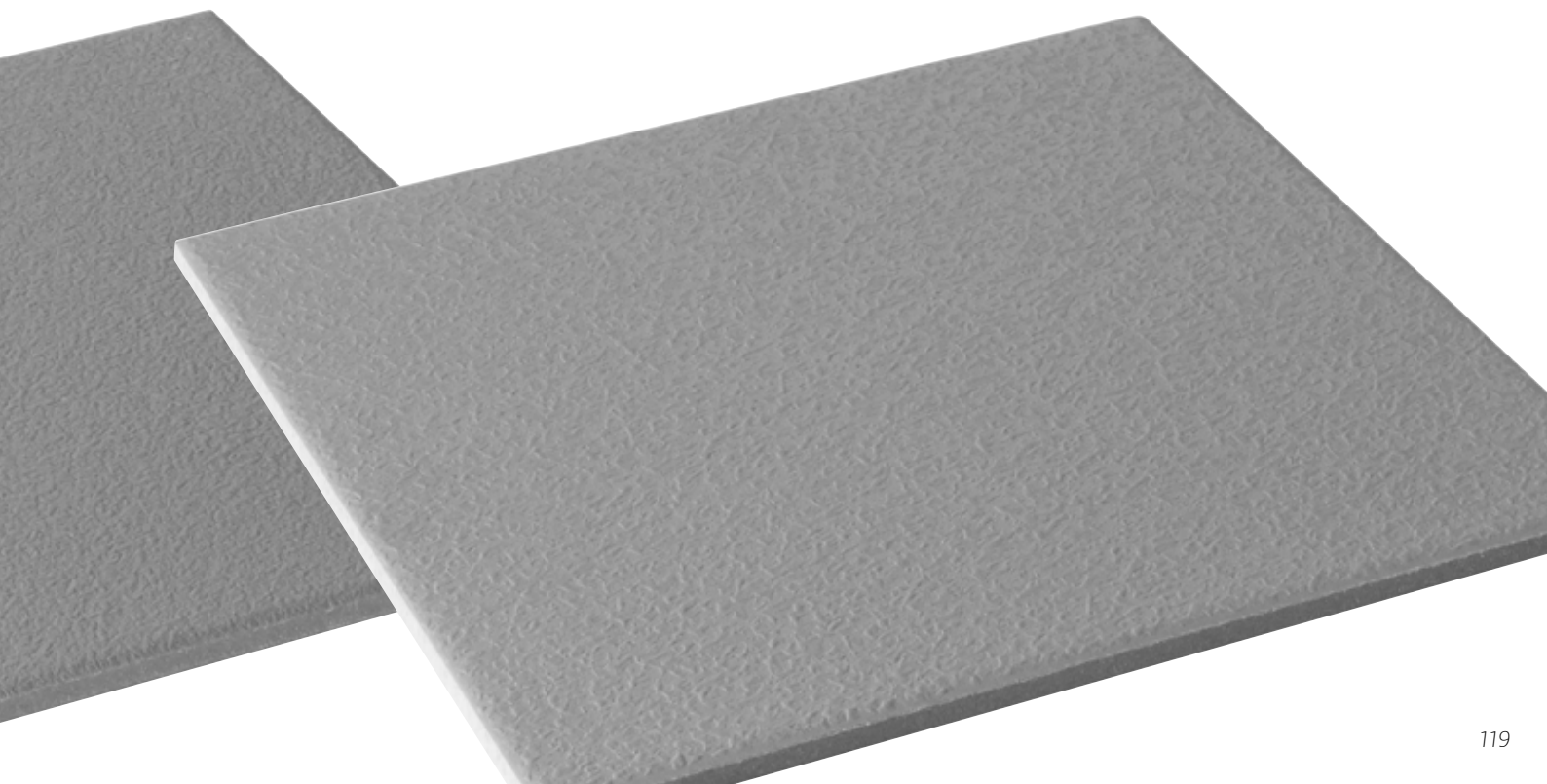

IN ghiaccio

P.E.I. ④

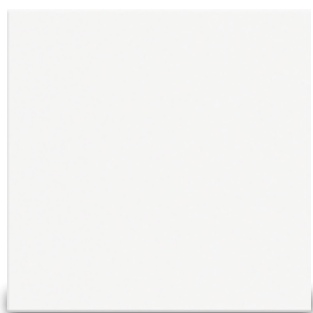

40x40 cm

IN latte

P.E.I. ④

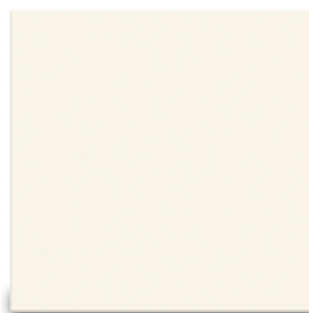

40x40 cm

IN seta

P.E.I. ④



40x40 cm

IN nocciola

P.E.I. ②



40x40 cm

IN caffè

P.E.I. ①



40x40 cm

IN mandarino

P.E.I. ③



40x40 cm

IN pompelmo

P.E.I. ④



40x40 cm

IN pistacchio

P.E.I. ④



40x40 cm



IN oliva

P.E.I. ②



40x40 cm

IN azzurro

P.E.I. ④

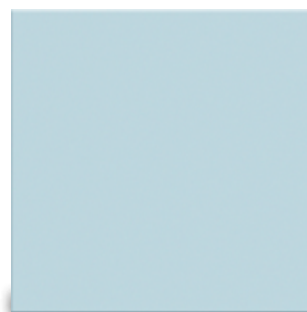

40x40 cm

IN oltremare

P.E.I. ②



40x40 cm

IN argento

P.E.I. ③



40x40 cm

IN ferro

P.E.I. ②



40x40 cm

IN nero

P.E.I. ①



40x40 cm

Utilizzo: interni ed esterni, pavimenti e rivestimenti  
 Uso: interiores y exteriores, pavimentos y revestimientos  
 Использование: внутренняя и наружная отделка, полы и облицовка  
 使用: 室內和室外, 牆地兩用磚

Formati  
 Formatos 40x40 }  
 Formatos 16"x16" }  
 Форматы }  
 尺寸 }  
 0,85 cm

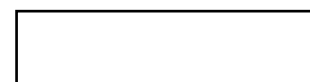

9,5x40  
 3¾"x16"

Battiscopa  
 Rodapiés  
 Плинтус  
 壁

RF ghiaccio

P.E.I. ④

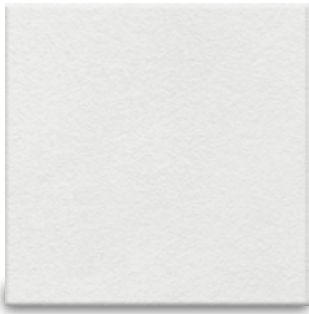

40x40 cm

RF seta

P.E.I. ④



40x40 cm

RF tortora

P.E.I. ③



40x40 cm

RF rosso

P.E.I. ③



40x40 cm

RF mandarino

P.E.I. ③



40x40 cm

RF giallo

P.E.I. ③



40x40 cm

RF menta

P.E.I. ①



40x40 cm

RF turchese

P.E.I. ②



40x40 cm

RF laguna

P.E.I. ④



40x40 cm

RF azzurro

P.E.I. ④



40x40 cm

RF blu avio

P.E.I. ③



40x40 cm

RF oltremare

P.E.I. ②



40x40 cm

RF argento

P.E.I. ④



40x40 cm

RF grigio

P.E.I. ③



40x40 cm

RF ferro

P.E.I. ②



40x40 cm

RF nero

P.E.I. ①



40x40 cm

Utilizzo: interni ed esterni, pavimenti - R10  
 Uso: interiores y exteriores, pavimentos - R10  
 Использование: внутренняя и наружная отделка, полы - R10  
 使用: 室内和室外, 地面 - R10

Formati  
 Formatos 40x40 }  
 Форматы 16"x16" }  $\frac{\nabla}{\blacktriangle} 0,85$  cm  
 尺寸

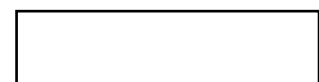

9,5x40  
 3¾"x16"

Battiscopa - disponibile nella finitura *Interni*  
 Rodapiés - disponible en el acabado *Interni*  
 Плинтус - доступен в отделке *Interni*  
 壁脚板-擁有 *Interni* 表面

**IG ghiaccio**

P.E.I. ④



40x40 cm

**IG seta**

P.E.I. ④



40x40 cm

**IG tortora**

P.E.I. ③



40x40 cm

**IG argento**

P.E.I. ④



40x40 cm

IG grigio

P.E.I. ③



40x40 cm

Utilizzo: interni ed esterni, pavimenti - B (A+B)  
 Uso: interiores y exteriores, pavimentos - B (A+B)  
 Использование: внутренняя и наружная отделка, полы - B (A+B)  
 使用: 室内和室外, 地面 - B (A+B)

Formati  
 Formatos  
 Форматы  
 尺寸

40x40  
 16"x16" }  $\frac{\nabla}{\blacktriangle}$  0,85 cm



9,5x40  
 3¾"x16"

Battiscopa - disponibile nella finitura *Interni*  
 Rodapiés - disponible en el acabado *Interni*  
 Плинтус - доступен в отделке *Interni*  
 壁脚板-擁有 *Interni* 表面

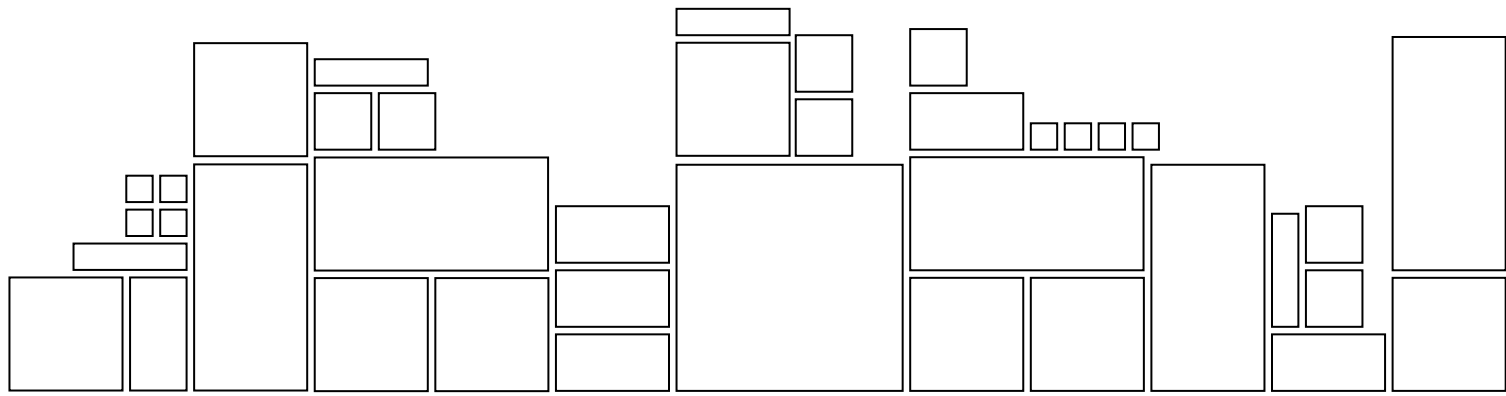

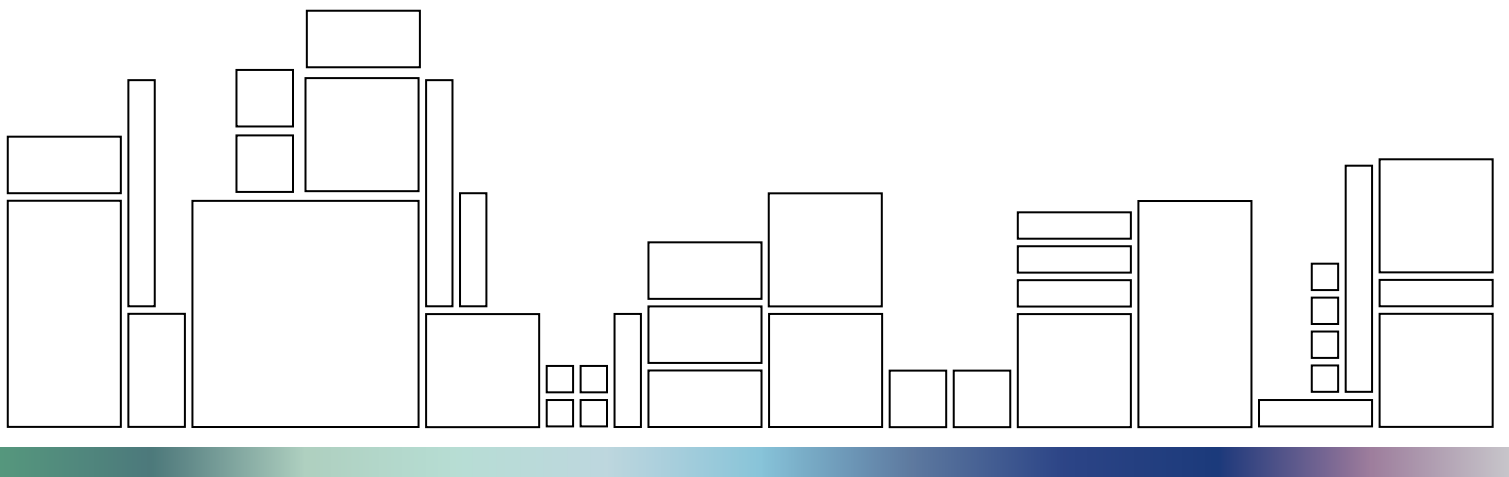

# VOGUE Pool

Bump C (A+B+C) V6

Special Pool

## Cos'è Vogue Pool

La collezione Vogue Pool offre prodotti e pezzi speciali appositamente studiati per la progettazione e realizzazione di piscine. A completamento della proposta, la collezione Vogue System, per il rivestimento delle vasche, nelle finiture satinata, lucide e antiscivolo R10 B (A+B) e R11 C (A+B+C), la collezione Vogue Link per creare piacevoli decorazioni sia a pavimento che a rivestimento e la collezione Vogue Floor disponibile in una vasta gamma cromatica nel formato 40x40 adatta anche a pavimentazioni tecniche R10 e B(A+B).

## Qué es Vogue Pool

La colección Vogue Pool ofrece productos y piezas especiales expresamente estudiados para el diseño y realización de piscinas. Para completar la propuesta, la colección Vogue System, para el revestimiento de piscinas, en los acabados satinados, brillantes y antideslizantes R10 B (A+B) y R11 C (A+B+C), la colección Vogue Link para crear agradables decoraciones, tanto en el suelo como para revestimiento, y la colección Vogue Floor disponible en una dilatada gama cromática en el formato 40x40 también adecuada para suelos técnicos R10 y B(A+B).

## Что такое Vogue Pool

В серию Vogue Pool входят изделия, специально разработанные для отделки бассейнов. Ассортимент дополняется серией Vogue System для облицовки чаш бассейнов с матовыми, глянцевыми и противоскользящими поверхностями R10 B (A+B) и R11 C (A+B+C), коллекцией Vogue Link, позволяющей создавать нарядные напольные и настенные декоры, и линией Vogue Floor, доступной в широком диапазоне расцветок в формате 40x40, которая пригодна в том числе и для напольных покрытий технического назначения R10 и B(A+B).

## 什么是Vogue Pool

Vogue Pool系列是为游泳池的设计和施工而专门设计的产品和特殊配件。为了提供成套产品，用于游泳池表层的Vogue System系列产品具有亚光、抛光和防滑饰面 R10 B (A+B) 和 R11 C (A+B+C)；Vogue Link系列用于在地板或墙壁上形成令人赏心悦目的装饰；Vogue Floor系列中尺寸为40x40的产品具有多种色调的选择，也适用于技术地板R10 和B(A+B)使用。



## Bump C (A+B+C) V6

Superficie strutturata da tratti lineari che garantiscono un grado di antiscivolo - gruppo C (A+B+C) - a piedi nudi. Prodotto ideale per il rivestimento di bordi vasca, lava piedi, zone di virata, gradini in presenza di acqua.

Superficie estructurada de rasgos lineales que garantizan un grado de efecto antideslizante - grupo C (A+B+C) - con pies descalzos. Producto ideal para el revestimiento de bordes de piscinas, lava-pies, zonas de viraje, peldaños en presencia de agua.

Структурированная ребристая поверхность плитки обеспечивает степень защиты от скольжения группы C (A+B+C) при прохождении по ней босиком. Данная продукция идеально подходит для облицовки бортиков бассейнов, моек для ног, зон для разворота, ступеней, погружённых в воду.

采用直线条纹的饰面能确保一定程度的防滑性 - C组 (A+B+C) - 赤足。用于覆盖泳池边缘, 洗脚池, 转弯区域, 潮湿阶梯的理想产品。

## Special Pool

Una gamma di pezzi speciali appositamente studiati per realizzare la maggior parte dei bordi vasca, prodotti anche con lunghezza 10 cm per offrire la soluzione ottimale anche in presenza di profili di vasca curvilinei.

Una gama de piezas especiales expresamente estudiadas para hacer la mayoría de los bordes de piscinas, producidos también con largos de 10 cm para ofrecer la solución ideal en presencia de perfiles de piscina curvilíneos.

Гамма специальных элементов, предназначенных для реализации большинства типов бортиков бассейнов с изделиями длиной до 10 см позволяет создавать оптимальные решения, в том числе при наличии в бассейне изогнутых профилей.

一系列特殊产品, 为泳池边缘主要部分的施工而专门设计, 包括长度仅为10厘米的产品, 它们能为具有曲线轮廓的泳池提供最佳解决方案。

**Bump C (A+B+C) V6** superficie antiscivolo strutturata superficie estructurada antidesglisante Структурированное



BP ghiaccio BP seta BP turchese BP laguna BP cielo BP cobalto BP grigio BP nero

Utilizzo: interni ed esterni, pavimenti - C (A+B+C) V6  
 Uso: interiores y exteriores, pavimentos - C (A+B+C) V6  
 Использование: внутренняя и наружная отделка, полы - C (A+B+C) V6  
 使用: 室内和室外, 地面 - C (A+B+C) V6

Formati 10x20  
 Formatos 4'x8"  
 Форматы 10x20  
 尺寸 4'x8" }  $\frac{\nabla}{\blacktriangle}$  0,7 cm

**Special Pool** superficie antiscivolo strutturata superficie estructurada antidesglisante Структурированное



cod. BR ghiaccio cod. BR turchese cod. BR cobalto cod. BR nero

Utilizzo: interni ed esterni  
 Uso: interiores y exteriores  
 Использование: внутренняя и наружная отделка  
 使用: 室内和室外

Formati 6,3x20  
 Formatos 2½"x8"  
 Форматы 6,3x10  
 尺寸 2½"x4" }  $\frac{\nabla}{\blacktriangle}$  2,2 cm



cod. BC ghiaccio cod. BC turchese cod. BC cobalto cod. BC nero

Utilizzo: interni ed esterni  
 Uso: interiores y exteriores  
 Использование: внутренняя и наружная отделка  
 使用: 室内和室外

Formati 10x20  
 Formatos 4'x8"  
 Форматы 10x10  
 尺寸 4'x4" }  $\frac{\nabla}{\blacktriangle}$  0,7 cm

**BP - Bump C (A+B+C) V6**

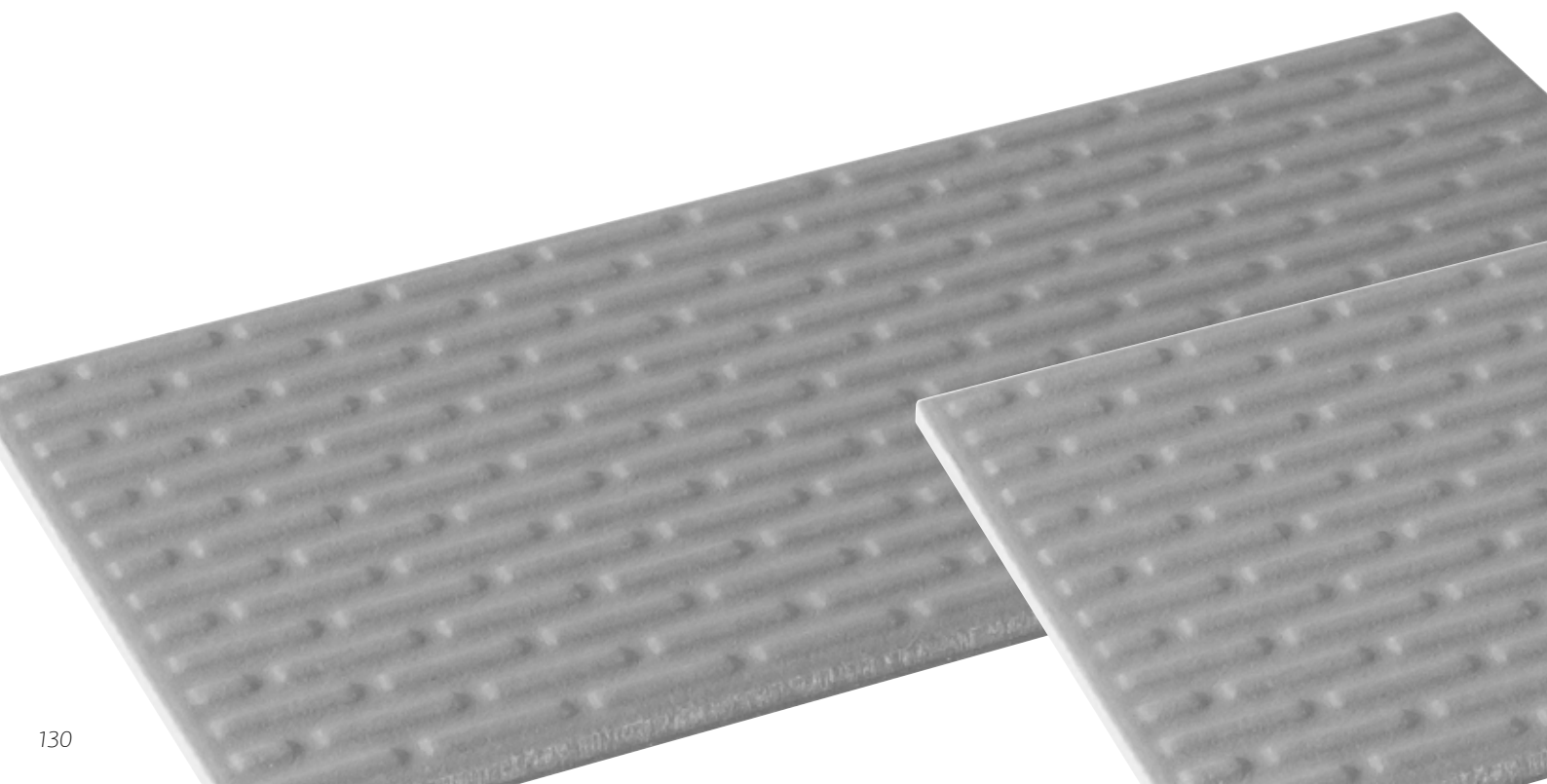

противоскользящее покрытие 防滑纹表面

противоскользящее покрытие 防滑纹表面



cod. FU ghiaccio    cod. FU turchese    cod. FU cobalto    cod. FU nero

Utilizzo: interni ed esterni

Uso: interiores y exteriores

Использование: внутренняя и наружная отделка

使用: 室內和室外

Formati	4,5x20	} 3 cm
Formatos	1¾"x8"	
Форматы	4,5x10	} 3 cm
尺寸	1¾"x4"	

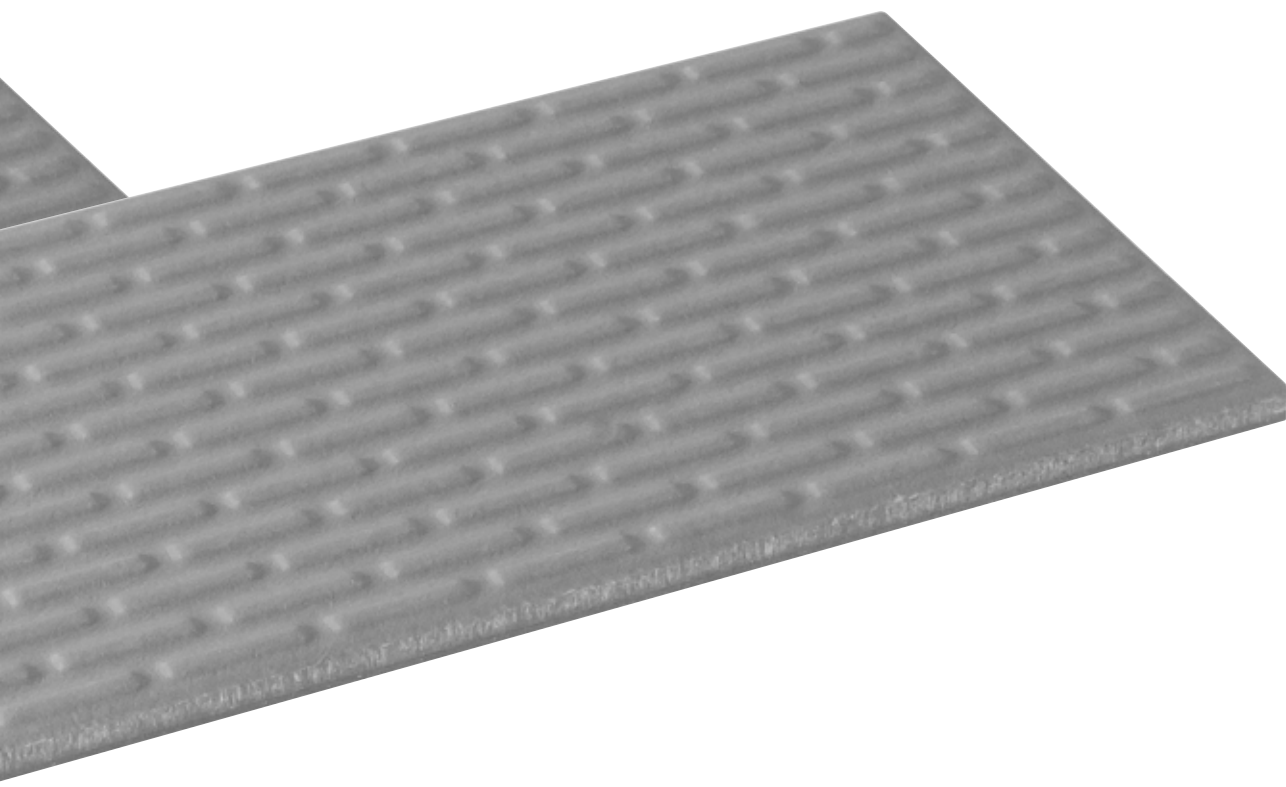

BP ghiaccio



10x20 cm

BP seta

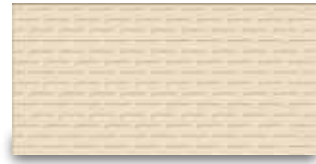

10x20 cm

BP turchese



10x20 cm

BP laguna



10x20 cm

BP cielo

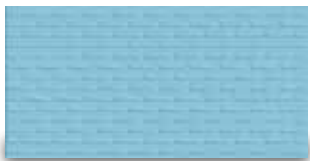

10x20 cm

BP cobalto

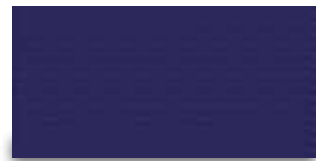

10x20 cm

BP grigio



10x20 cm

BP nero



10x20 cm

Utilizzo: interni ed esterni, pavimenti - C (A+B+C) V6  
 Uso: interiores y exteriores, pavimentos - C (A+B+C) V6  
 Использование: внутренняя и наружная отделка, полы - C (A+B+C) V6  
 使用: 室内和室外, 地面 - C (A+B+C) V6

Formati  
 Sizes  
 Formate  
 Formats

10x20 }  
 4"x8" }  $\frac{\nabla}{\blacktriangle}$  0,7 cm

cod. BC ghiaccio

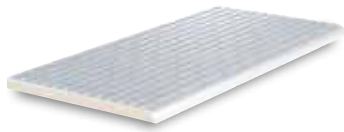

10x20 cm

cod. BR ghiaccio



6,3x20 cm

cod. FU ghiaccio



4,5x20 cm

cod. BC turchese

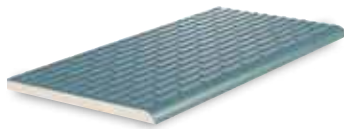

10x20 cm

cod. BR turchese



6,3x20 cm

cod. FU turchese

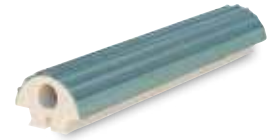

4,5x20 cm

cod. BC cobalto

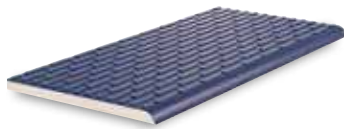

10x20 cm

cod. BR cobalto



6,3x20 cm

cod. FU cobalto



4,5x20 cm

cod. BC nero

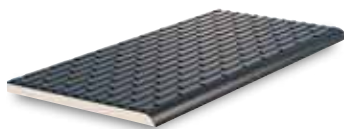

10x20 cm

cod. BR nero



6,3x20 cm

cod. FU nero



4,5x20 cm

Utilizzo: interni ed esterni  
 Uso: interiores y exteriores  
 Использование: внутренняя и наружная отделка  
 使用: 室内和室外

Formati  
 Sizes  
 Formate  
 Formats

Cod. BC 10x20 }  
 4'x8" }  $\frac{\nabla}{\blacktriangle}$  0,7 cm

Cod. BR 6,3x20 }  
 2½'x8" }  $\frac{\nabla}{\blacktriangle}$  2,2 cm

Cod. FU 4,5x20 }  
 1¾'x8" }  $\frac{\nabla}{\blacktriangle}$  3 cm

Cod. BC1 10x10 }  
 4'x4' }  $\frac{\nabla}{\blacktriangle}$  0,7 cm

Cod. BR1 6,3x10 }  
 2½'x4' }  $\frac{\nabla}{\blacktriangle}$  2,2 cm

Cod. FU1 4,5x10 }  
 1¾'x4' }  $\frac{\nabla}{\blacktriangle}$  3 cm

**Sistema Finlandese** Sistema Finlandés Финская система 芬兰系统

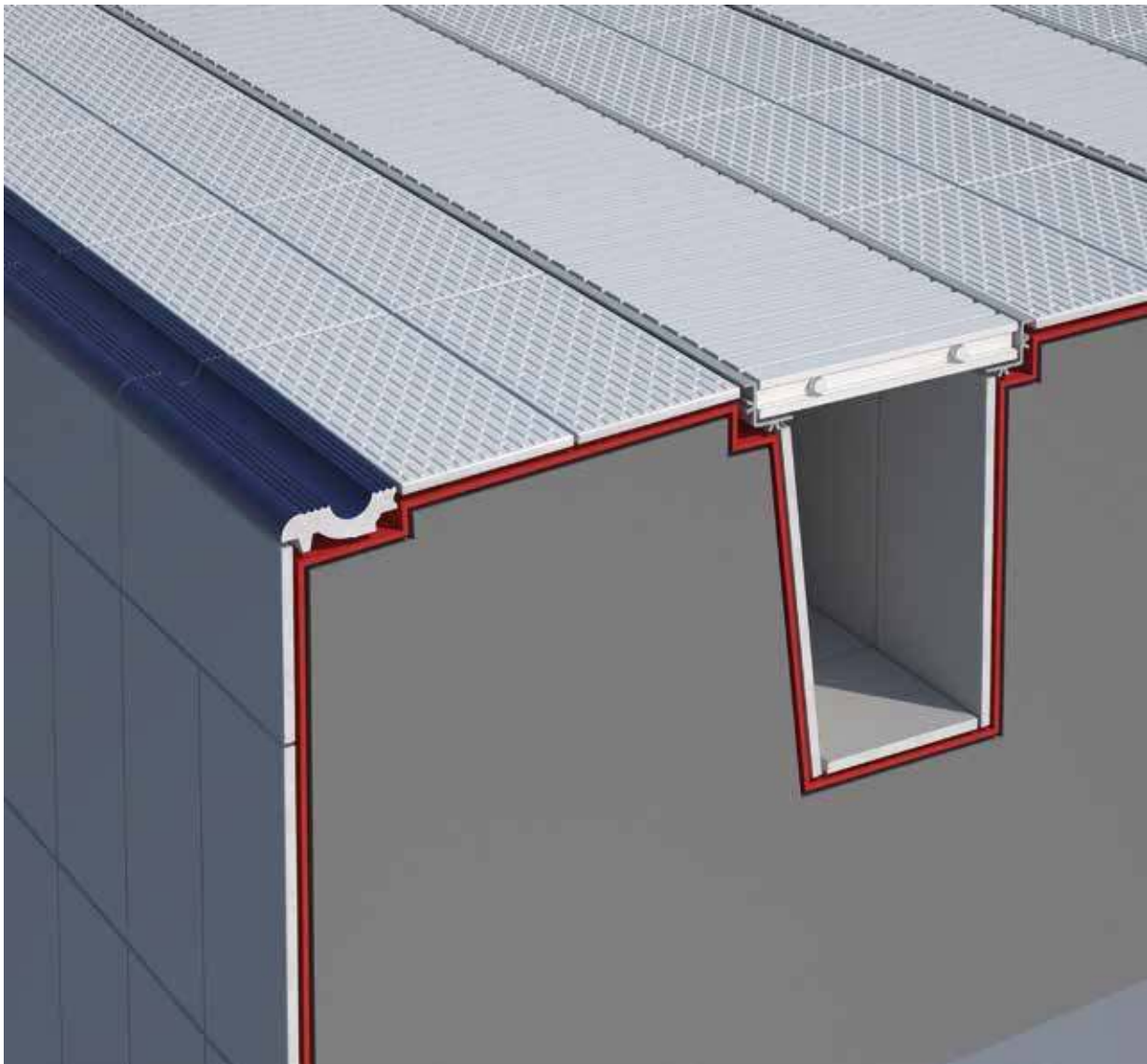

1. cod. BR 6,3x20

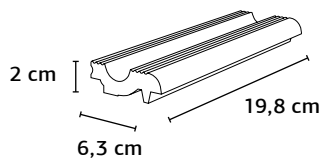

2. BP 10x20

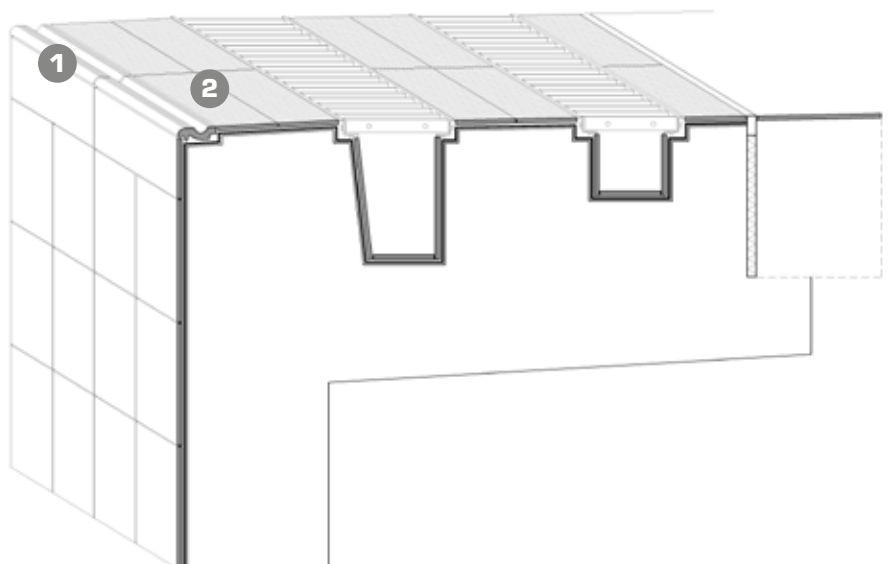
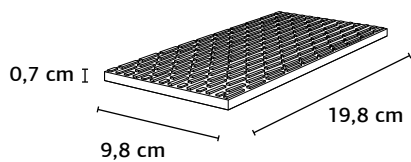



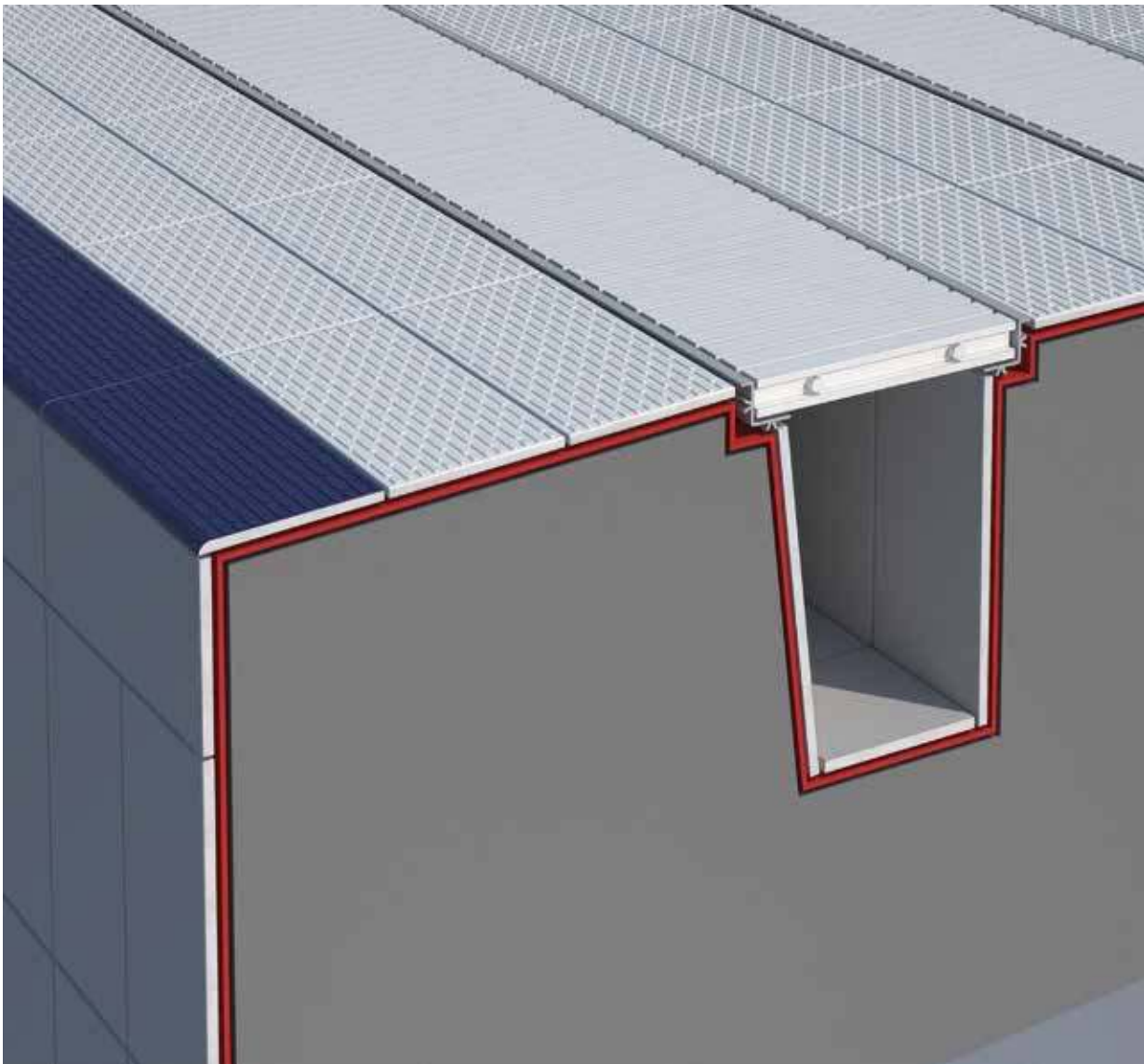

1. cod. BC 10x20

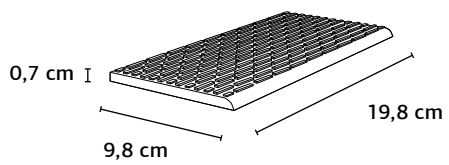

2. BP 10x20

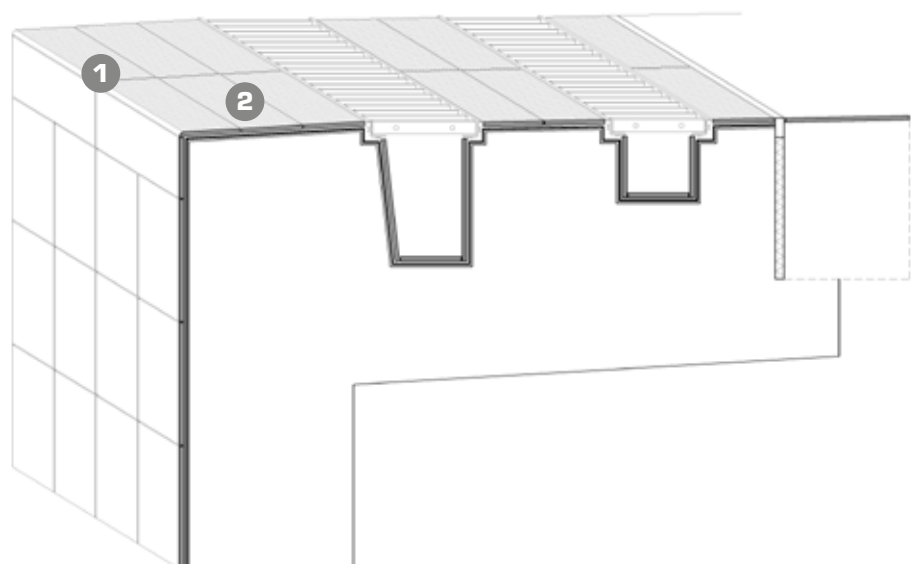
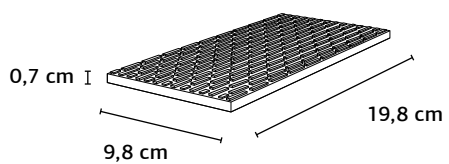

**Sistema Zurigo** Sistema Zúrich Цюрихская система 苏黎世系统

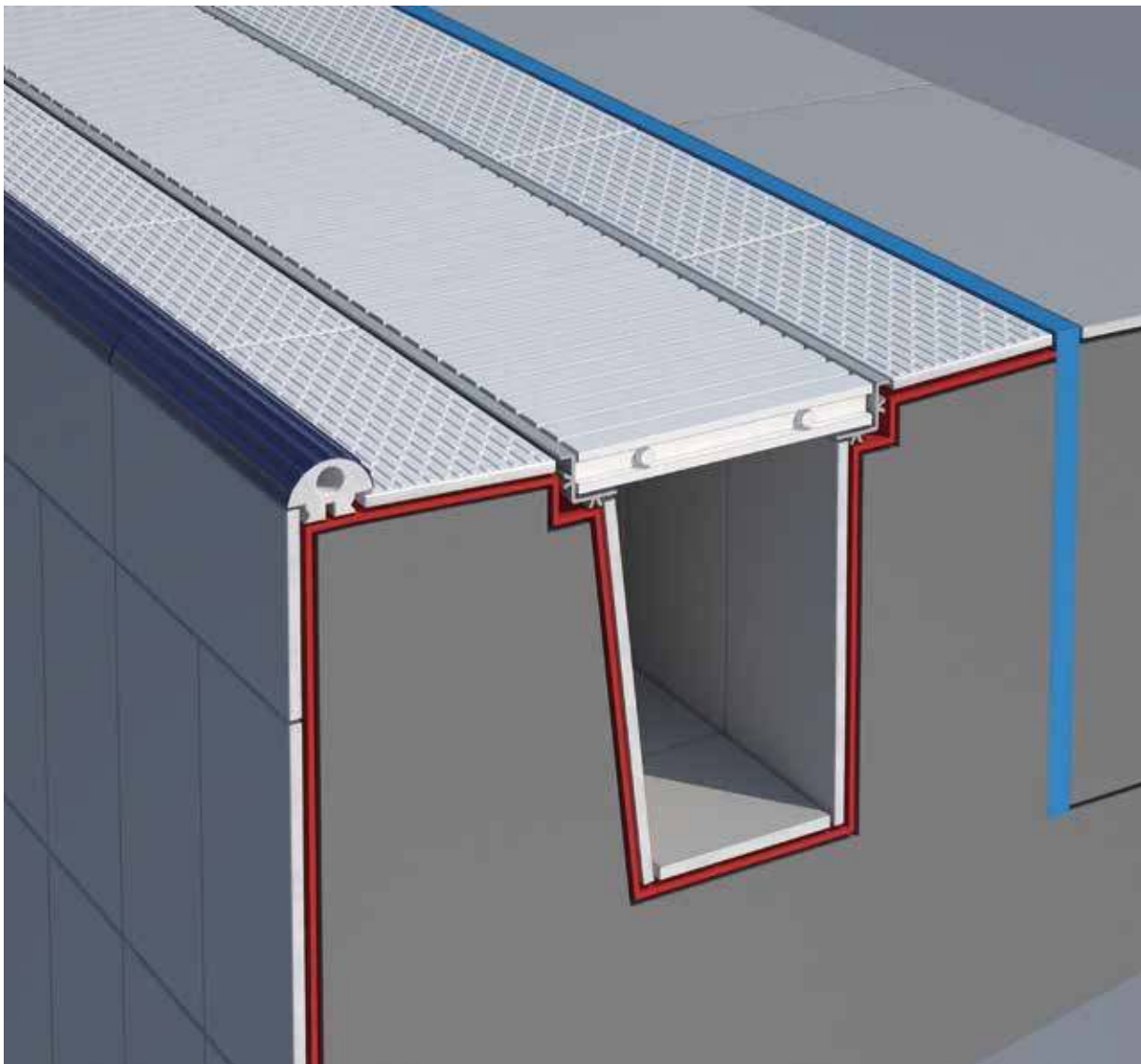

1. cod. FU 4,5x20

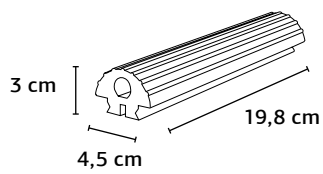

2. BP 10x20

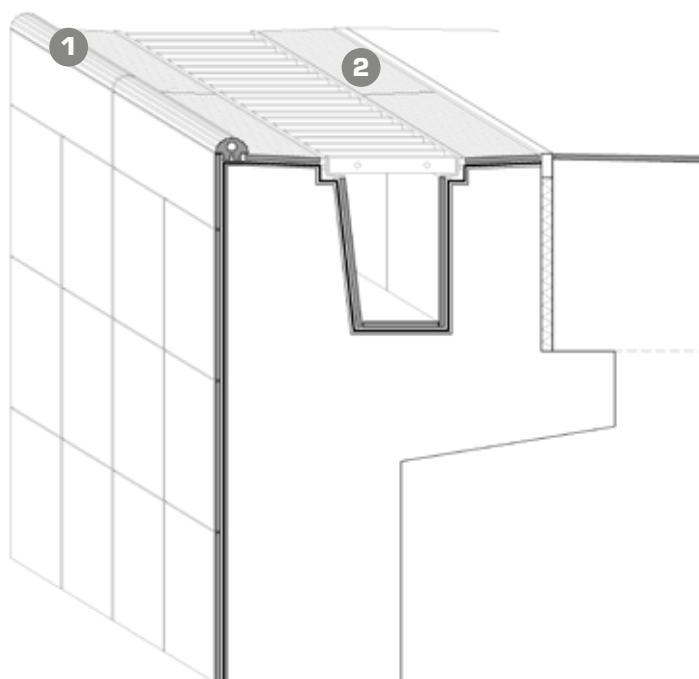
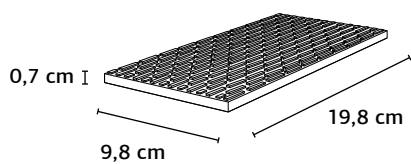



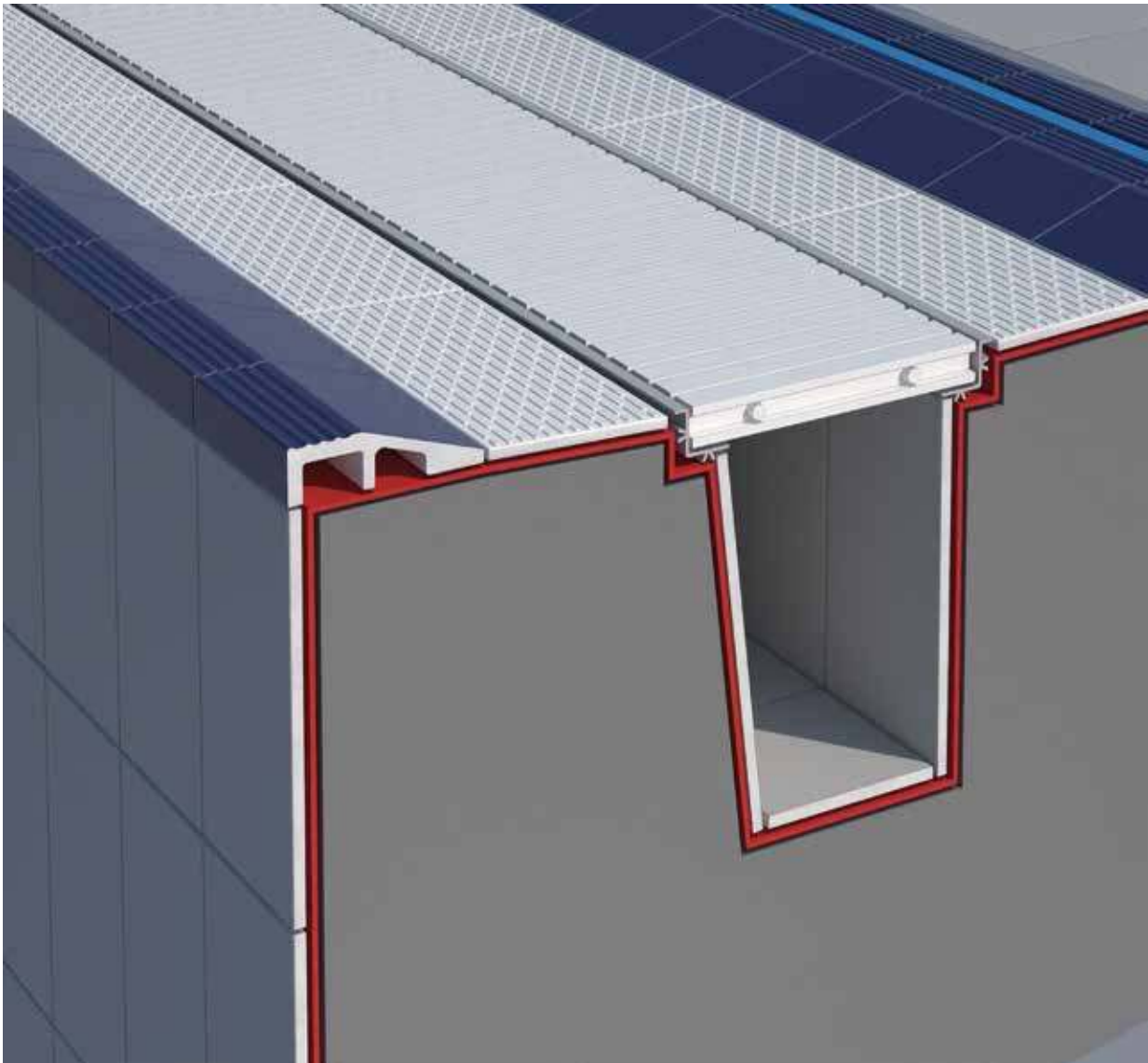

**1. cod. B 10x10**

**Vogue System** (p. 24)

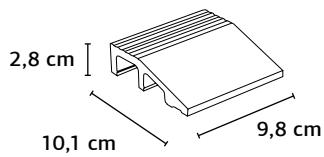

**2. BP 10x20**

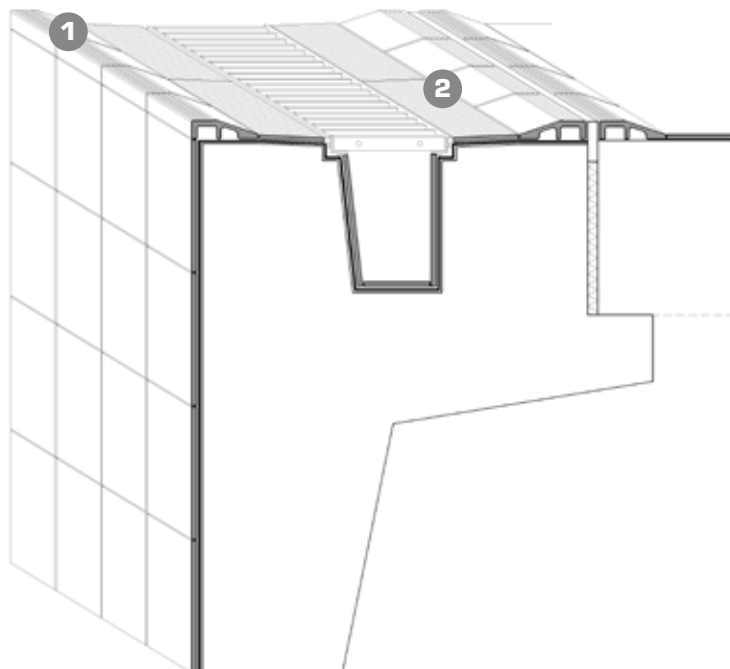
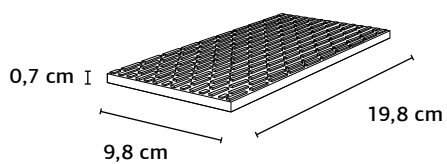

**Sistema Skimmer** Sistema Rebosadero Система со скиммером 撇渣系统

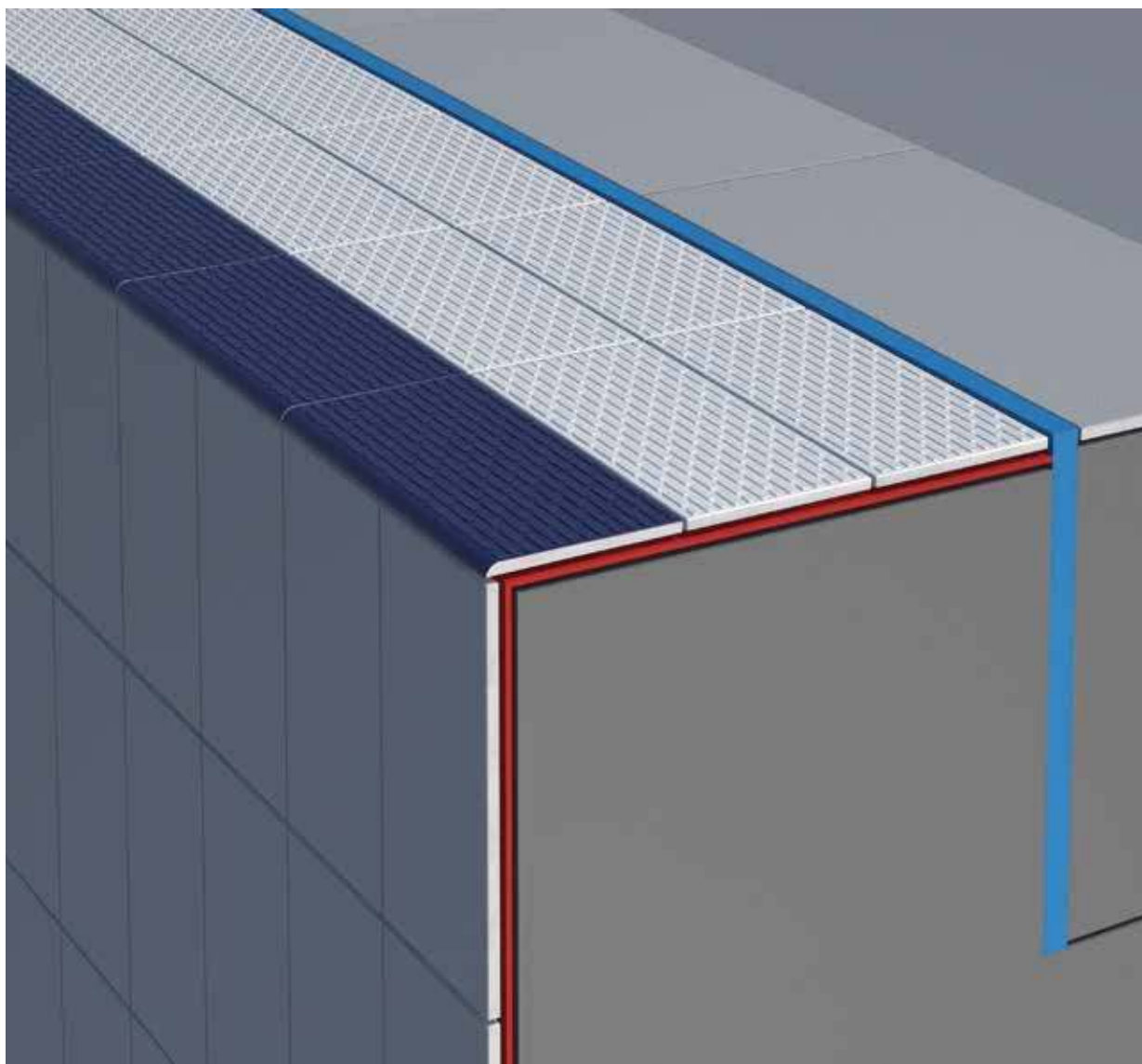

1. cod. BC 10x20

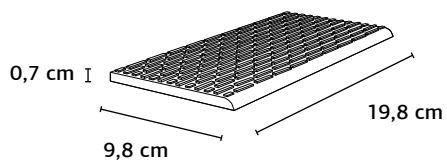

2. BP 10x20

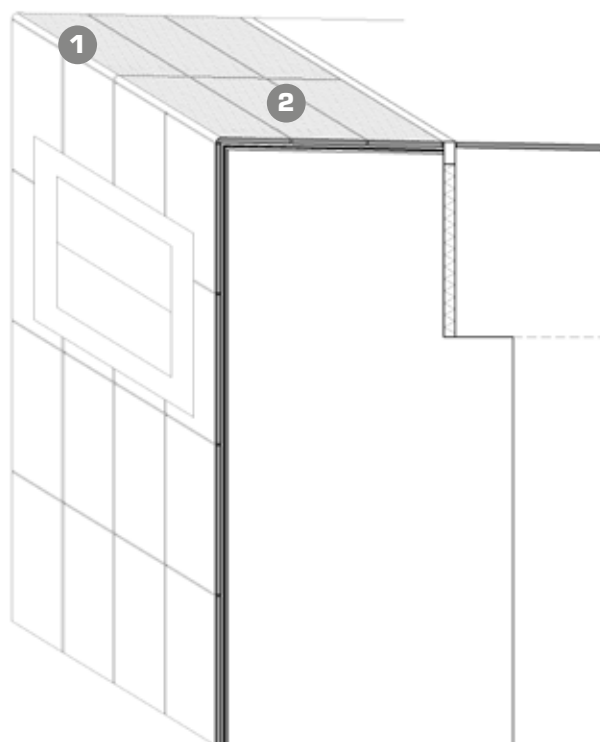
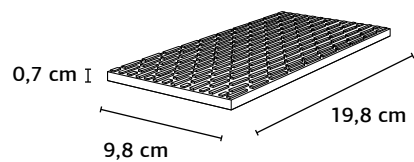

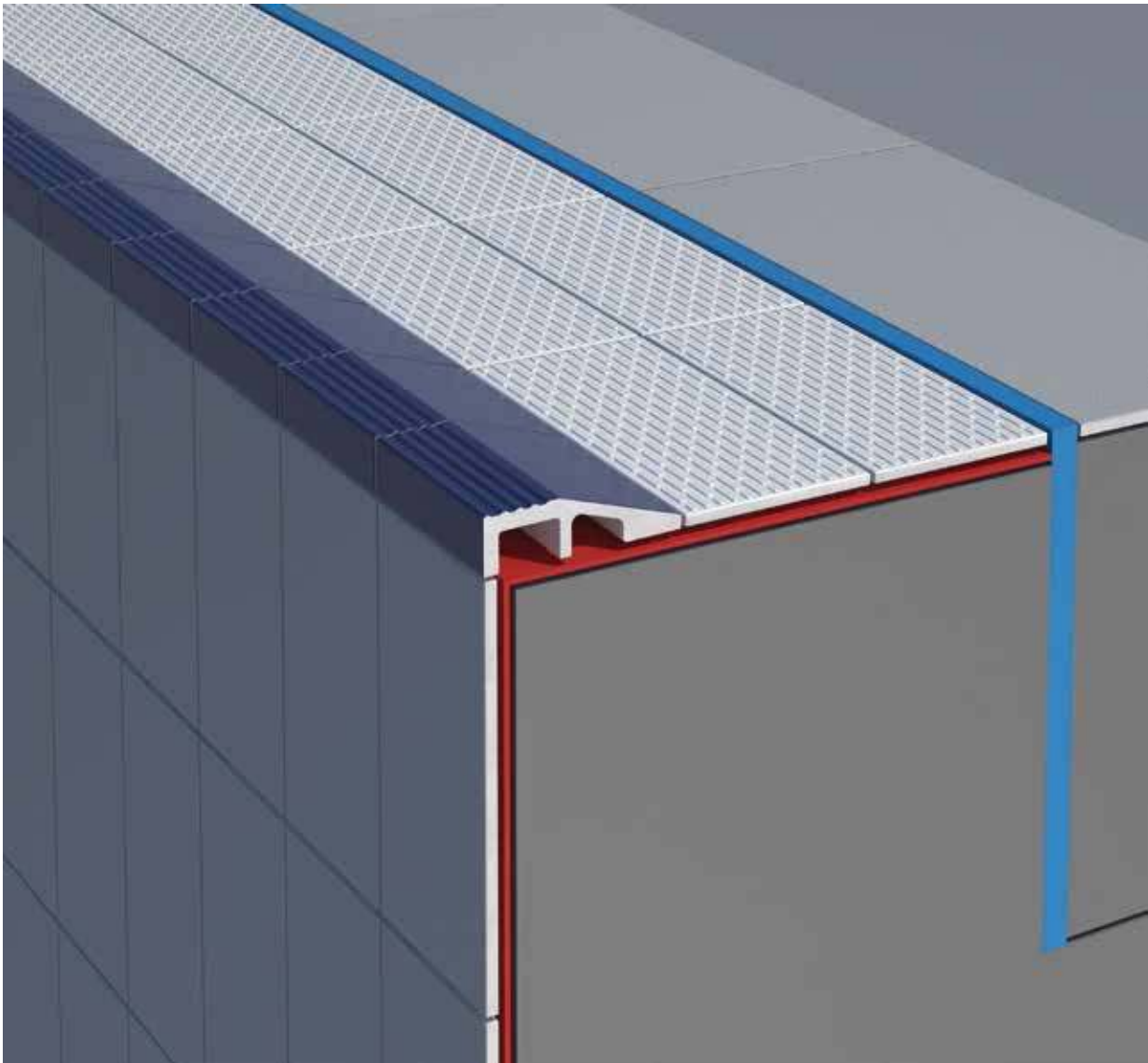

1. cod. B 10x10

Vogue System (p. 24)

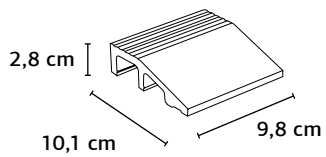

2. BP 10x20

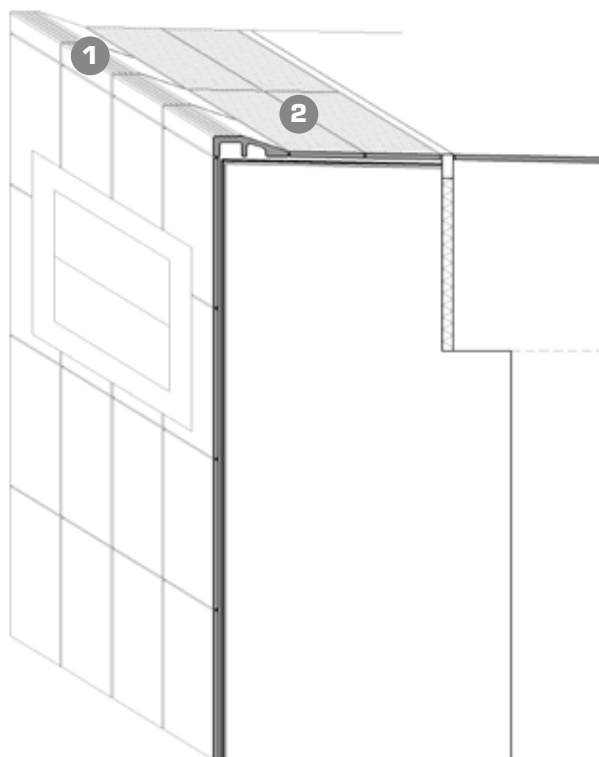
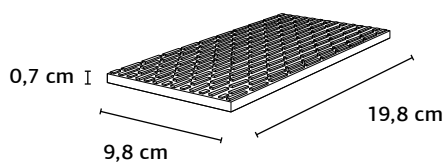

Gradino di riposo Escalón de descanso Ступенька для отдыха 休息踏板



1. BP 10x20

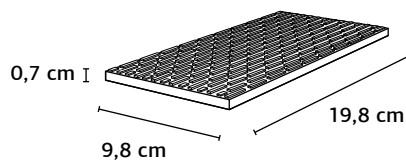

2. cod. N 2,5x20

Vogue System (p. 24)

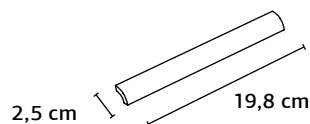

3. cod. M 2,5x20

Vogue System (p. 24)

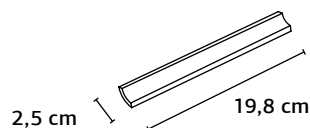

Scala e gradini Escalera y escalones Лестница и ступеньки 台阶和踏板

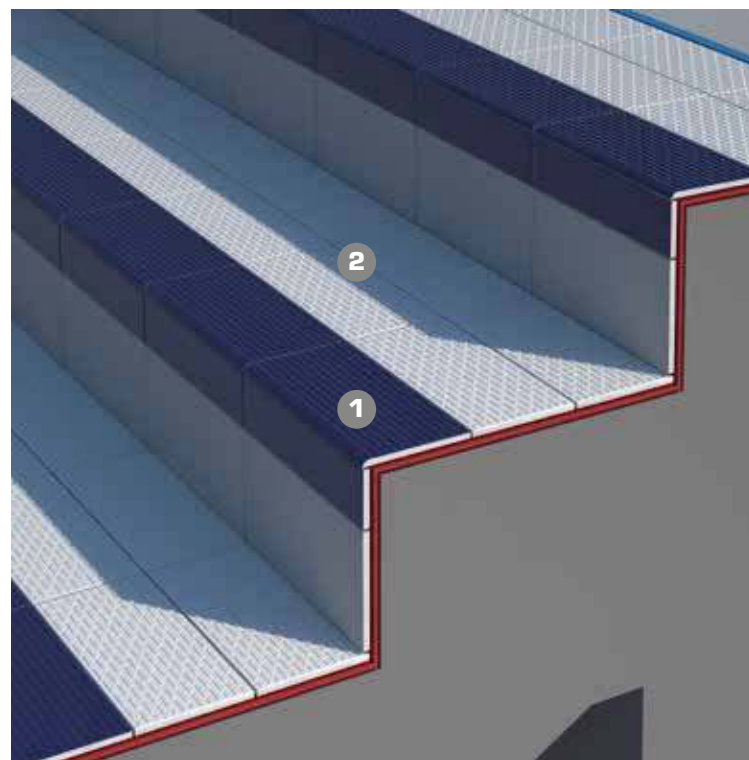

1. cod. BC 10x20

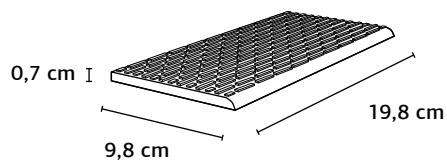

2. BP 10x20

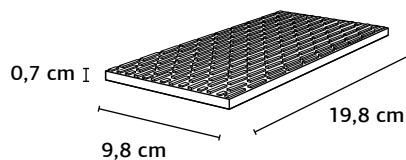

Muretto Pared Парапет 矮墙



1. BP 10x20

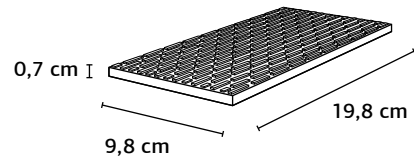

2. cod. K 2,5x10

Vogue System (p. 24)

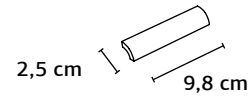

3. cod. F 2,5x2,5

Vogue System (p. 24)

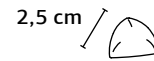

4. cod. N 2,5x20

Vogue System (p. 24)

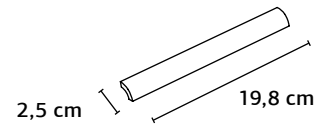





# Referenze

Referencias

Проекты

参考

**Biblioteca S.M.S. Luigi Lombardi**

Bari (BA) - Italy

*Project: ma0/Studio d'architettura*















**Soweto Theatre**  
Johannesburg - South Africa  
Project: Afritects



**Falkensteiner Hotel&Spa**  
Jesolo (VE) - Italy  
*Project: Matteo Thun & Partners*









**Collegi Universitari San Paolo  
e Crocetta Einaudi**  
Torino (TO) - Italy  
*Project: arch. Luca Moretto*





**Asilo nido Girotondo**

Piacenza (PC) - Italy

Project: FA+FB Fabio Boiardi Filippo Armani architetti









**Residenza privata**  
Torino (TO) - Italy  
*Project: Uda Architects*





**Negozi Camper**  
di Londra, Glasgow e Genova  
Projet: Tomás Alonso Design Studio









Train Number	Platform
101	1
102	2
103	3
104	4
105	5





**Stazione ferroviaria**  
**Sopot - Polonia**  
Sopot - Poland  
Project: arch. Krzysztof Stepiński



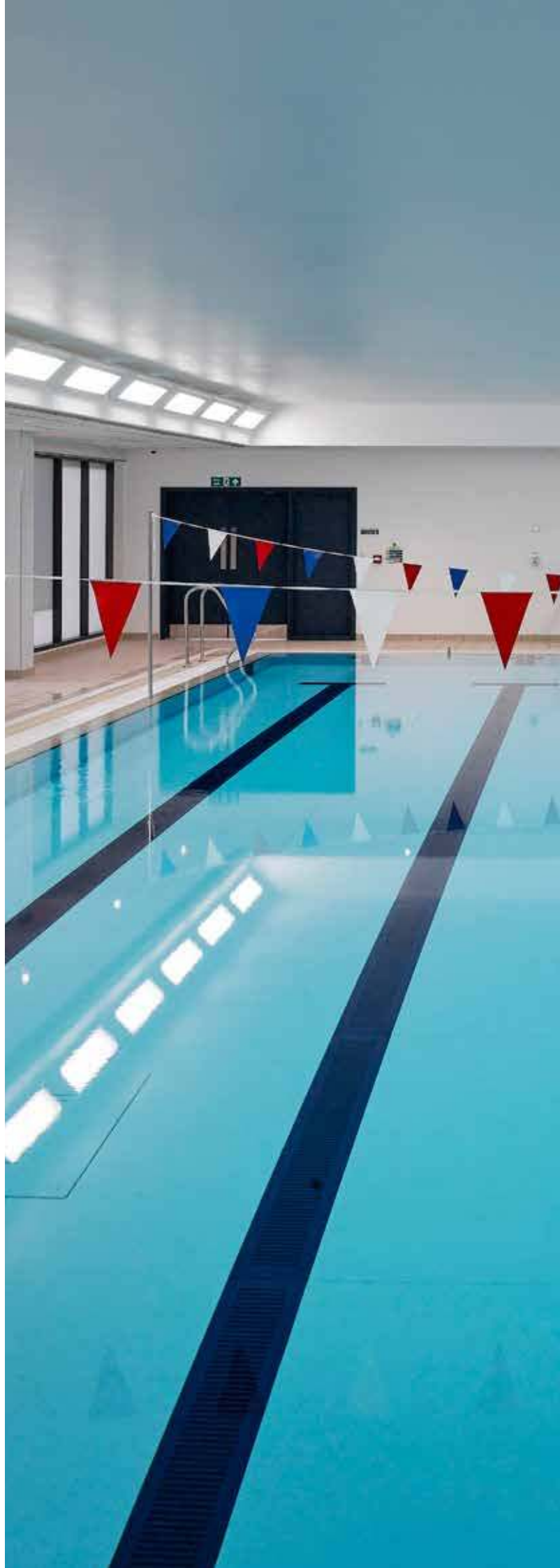

**Huddersfield Leisure Centre**  
Huddersfield - United Kingdom  
Project: Bam Construct Uk Ltd









**Azienda Ospedaliera Universitaria Meyer**  
**Ospedale Pediatrico**  
Firenze (FI) - Italy  
*Project: CSPE (Centro Studi Progettazione Edilizia)*





**Apartment Rue De Lille**

Paris - France

Project: arch Paola Bagna Simon - Spamroom  
Architecture And Design Studio









**Negozio Aēsop**  
Milano (MI) - Italy  
Project: DIMORESTUDIO





**Torri Garibaldi**  
**Sede Maire Tecnimont**  
Milano (MI) - Italy  
*Project: Progetto CMR – arch. Massimo Roj*















**Aquapark**  
Uherské Hradiště - Czech Republic  
Project: Saura Development Solutions



**Villeverde Hotel & Resort**  
**Wellness Spa & Golf**  
Fagagna (UD) - Italy  
*Project: Prinic&Partners*













**Sede Assicurazione Allianz**  
Budapest - Hungary  
Project: Schüller és Társai Építésziroda Kft. / Schüller  
Ferenc





**Hippopotamus Restaurant Grill – Budapest Airport**  
Budapest - Hungary  
Project: T-W Interiors Kft.



# NEGRONI

pizza · pasta · panini









**Campus Scholaire**  
Capellen - Luxembourg  
*Project: Atelier d'Architecture et de Design Jim Clemes s.a.*



**Negozio calzature "Little Shoes"**  
Barcellona - Spain  
*Project: Nabito Architects*











**Rep. pediatria Ospedale Causa Pia Luvini**  
Cittiglio (VA) - Italy  
*Project: Il Ponte del Sorriso Onlus*





**C. C. "Centro Sicilia"- Iperspar**  
Catania (CT) - Italy  
Project: Design International





I migliori formaggi  
con un tocco siciliano.

IL CASARO

**Offerta**  
FORMAGGIO  
ASIAGO TA  
**€ 0.69**

**TAKE AWAY**  
FRESCHIZIAE QUALITÀ

**Offerta**  
EMMENTALER  
SVIZZERO TA  
**€ 0.79**

**Offerta**  
PROVONE PICCOLI  
TINO TA  
**€ 0.99**

0.15 1.88 1.66 0.69 0.78 0.99









**Palazzine per uffici Metro Complex**  
Milano (MI) - Italy  
*Project: arch. David Dydek*



**Casa dei Bambini Scuola Montessori**  
Milano (MI) - Italy  
Color project: Francesca Valan







## **Ospedali, assistenza Hospitales, asistencia Больницы, помощь 医院, 服务**

Castle Peak Hospital (Hong Kong) | Groupe Hospitalier Pitie Salpetriere Paris (Francia) | IOMI Istituto Ortopedico Mezzogiorno Italia Ganzirri (Italia) | Ospedale Benesov (Repubblica Ceca) | Ospedale Gallipoli (Italia) | Ospedale Swidnica (Polonia) | Senior Citizen at Jordan Valley (Hong Kong) | Casa di riposo A. Galvan Padova (Italia) | Polo Pediatrico Meyer Firenze (Italia) | Clinica Veterinaria Città di Bari (Italia) | Centro riabilitazione funzionale Fisio&Lab Torino (Italia) | Casa Maggio Casa di riposo della Città di Chieri (Italia) | Seniorenheim Ergoldsbach (Germania) | Reparto Pediatria Ospedale Causa Pia Luvini Cittiglio (Italia) | Nuovo Ospedale Universitario Karolinska Stoccolma (Svezia)

## **Istruzione e cultura Educación y cultura Образование и культура 教育和文化**

Bibliothèque de Lille (Francia) | Crumling High School/Jerry Loughery Archs (Irlanda del Nord) | FIU Miami University Miami (USA) | Mensa Universitaria Pisa (Italia) | Opera House Oslo (Norvegia) | Palazzo Grassi Venezia (Italia) | Sede Scuola Gambero Rosso Roma (Italia) | South Cambridge District School/Auckkets (Regno Unito) | Teatro La Fenice Venezia (Italia) | Università di Bressanone (Italia) | Università di Fisciano (Italia) | West London Academy/Foster & Partners (Regno Unito) | Asilo Nido Girotondo Piacenza (Italia) | Biblioteca S.M.S. Luigi Lombardi Bari (Italia) | Collegio Universitario San Paolo Einaudi Torino (Italia) | Collegio Universitario Crocetta Einaudi (Italia) | Scuola di danza Open Dance Center Milano (Italia) | Istituto Alberghiero Pellegrino Artusi Riolo Terme (Italia) | Scuola Materna "S. Giuseppe" Paraga di Vigenza (Italia) | Acquario Cattolica (Italia) | Casa dello Studente Firenze (Italia) | Soweto Theatre Johannesburg (South Africa) | Casa dei Bambini Scuola Montessori Milano (Italia) | American International School Budapest (Hungary) | Scuola e palestra Schönbuch Stoccarda (Germania) | Asilo Nido Perugina Kilipupu Perugia (Italia)

## **Residenziale Residencial Жилой 居住**

Waterside Apartments Kinsale (Irlanda) | Wohnpark Westerland/Sylt (Germania) | Selvaag Bygg AS Oslo (Norvegia) | Shatin 2B residential towers (Hong Kong) | Tai Koo Valley site V residential towers (Hong Kong)

## **Ospitalità Alojamiento Гостеприимство 餐旅**

Circolo Nautico Ruggiero di Lauria (Italia) | Club Med (All over the world) | Complesso Alimini Otranto (Italia) | Hayatt Hotel Varsavia (Polonia) | Hotel Cosmopolitan Terme Ischia (Italia) | Hotel Le Ruote Cadeo (Italia) | Hotel Logoav Park/Broadway Maylan/Algarve (Portogallo) | Hotel Porro Salsomaggiore Terme (Italia) | Hotel Royal Casino-Softel Mandeleu-la-Napoule (Francia) | Hotel Schmidt Adelsried (Germania) | Hotels Eurodisney (Francia) | St. Joseph Society Center Mill Hills Father (Irlanda) | Sporthotel Waregem (Belgio) | Struttura alberghiera a Gioiosa Marea (Italia) | Villaggio Turistico La Madonna Follonica (Italia) | Villaggio turistico Valle di Mare (Italia) | Grand Hotel Salerno (Italia) | Navalys Hotel Klaipeda (Lithuania) | Casa dei Servi della Sofferenza S. Giovanni Rotondo (Italia)

## **Fitness-salute-sport Fitness-salud-deporte Фитнес-здоровье-спорт 健身-保健-运动**

Swimming Pool Hilton Hotel Praga (Repubblica Ceca) | Swimming Pool Hotel Gem Wroclaw (Polonia) | Fitness Center Hotel Stadion Budapest (Ungheria) | Swimming Pool Hyatt Hotel Dead Sea (Israele) | Swimming Pool Star Hotel Sidney (Australia) | Centre Sportif Aqua Club Val Thorens (Francia) | Centro Benessere Tropos Firenze (Italia) | Centro CONI Tirrenia (Italia) | Changing Rooms Formosa Auckland (Nuova Zelanda) | Club Mediterranée (All over the world) | Coleraine Sports Pavilion (Irlanda del Nord) | Dolphins Stadium Miami (USA) | Erlebnisbad Bonn (Germania) | Exerzieren-Haus Werdenfels (Germania) | Fonte del benessere centro fitness Siracusa (Italia) | Golf Club Cattolica (Italia) | Heilbachlandschaft Bad Kissingen (Germania) | Kurbad Bad Ems (Germania) | New Wembley Stadium/Foster & Partners (Regno Unito) | Swimming Pool Nowa Gdynia – Lodz (Polonia) | Palestra Le Club Piacenza (Italia) | Palestra Kontakt Soffiano Firenze (Italia) | Piscina Delfino Avola (Italia) | Swimming Pool Pioermel (Francia) | Thalassotherapie Carnac (Francia) | Zodiac Palestre Firenze (Italia) | Centro Ravviva S.c.s. Torino (Italia) | Aquapark Uherske Hradiste (Repubblica Ceca) | Piscina Opole (Polonia) | Piscina Suwalki (Polonia) | Likenai sanatorium swimming-pool Likenai (Lithuania)

## **Commerciali Comerciales Торговые 商业**

Auchan Bari (Italia) | Auchan Budapest (Ungheria) | Auchan Casa Massima (Italia) | Auchan Località Melilli (Italia) | Auchan Mesagne (Italia) | Auchan Modugno (Italia) | Champion (All over the world) | Carrefour (All over the world) | Coop Codis (Olanda) | Danish Supermarket (Danimarca) | IGA (Canada) | IKA Supermarket (Svezia) | Interspar (Repubblica Ceca) | IperCoop Piacenza (Italia) | Monoprix (All over the world) | Panorama (RM) | Pizza Hut (All over the world) | Sobey's (Canada) | MyChef (All over the world) | McDonald (Italia) | Innscor food chain (Africa) | RIMI supermarket chain in Lithuania (Latvia & Estonia) | IKEA exposition boxes in Vilnius (Lithuania) | IKEA exposition boxes in Espoo (Finland) | La Crepe creperie restaurant in Vilnius (Lithuania) | Rūta chocolate factory in Šiauliai (Lithuania) | Hippopotamus Restaurant Grill Budapest Airport (Hungary) | C.C. Centro Sicilia Iperspar Catania (Italia)

## **Varie Varios Разные 其他**

Aéroport de Bâle (Svizzera-Francia) | Autogrill (Italia) | Banca Popolare di Sondrio Lugano (Svizzera) | BBC – Fit Out and Base Building/Pringle Brandon & McCorman Jamieson (UK) | Belfast Royal Courts (Irlanda del Nord) | Bundesbahn Regensburg (Germania) | Centre de Loisir Plascese Isneauville (Francia) | Centre Immobilier Pierre et Vacances (Francia) | Cinema Multisala Lecce (Italia) | City Quay Offices Dublin (Irlanda) | Cucina e Sala mensa Regione Lazio (RM) | Exhibition Building Oslo (Norvegia) | Fiera di Bologna (Italia) | Filiale Mercedes Benz- Smart Roma (Italia) | Filiali Renault Roma (Italia) | Hala Sazka Praga (Repubblica Ceca) | Iceland Parliament Reykjavik (Islanda) | Industria Farmaceutica Eli Lilly Italia S.p.A Sesto Fiorentino (Italia) | Manchester Magistrate Courts/Gensler (Regno Unito) | Metro Station Schiedam (Olanda) | Mocarabia Coffee Bar (Italia) | Muro a mosaico in P.zza Borgo Dora Torino (Italia) | One North Wacker Tower Chicago (USA) | Porto Turistico Marina Cala De' Medici Castiglioncello (Italia) | Prinz. Leopold-Kaserne Regensburg (Germania) | Pump Station Los Angeles California (USA) | Queen Elisabeth 2 Cruiseship/ SMC Design (Regno Unito) | Salon Volvo Varsavia (Polonia) | Sede Empoli Calcio Empoli (Italia) | Shell Office Building Copenhagen (Danimarca) | Stazion Metro Rennes (Francia) | Stekleni Dvor uffici Ljubljana (Slovenia) | Telekomunikacja Varsavia (Polonia) | T+R Autobahnraststätte Irschenberg (Germania) | Uffici Ferrovie di Stato Roma (Italia) | Uffici Mediaset Milano (Italia) | Sottopasso Stazione Ferroviaria Sopot (Polonia) | Aeroporto Linate zona arrivi Milano (Italia) | Palazzine per uffici Metro Complex Milano (Italia) | Torri Garibaldi Sede Maire Tecnimont Milano (Italia) | Sede Assicurazione Allianz Budapest (Hungary) | Terme di Caracalla Roma (Italia) | Uffici R.A.I. in Via di Grottarossa Roma (Italia) | Ufficio Legale Dnepropetrovsk (Ucraina) | Uffici Palazzo Ravizza Milano (Italia)



# **Schede Tecniche**

**Fichas técnicas**

**Технические карты**

**技術圖表**

## Voci di capitolato Voces de libro de obras Смета 投標說明書

### Piastrelle di ceramica pressate a secco con basso assorbimento di acqua ( $0,5\% < E_b \leq 3\%$ )

#### Gruppo B1<sub>b</sub> - M - GL EN 14411:2012 appendice H.

Azulejos cerámicos, prensados en seco con reducida absorción de agua ( $0,5\% < E_b \leq 3\%$ )

Grupo B1<sub>b</sub> - M - GL EN 14411:2012 apéndice H

Керамическая плитка, сухой прессовки, с низким водопоглощением ( $0,5\% < E_b \leq 3\%$ )

Gruppo B1b M - GL EN 14411:2012 Приложение H

釉面瓷磚, 低吸水性乾壓而成 ( $0,5\% < E_b \leq 3\%$ )

B1b 組 - M - GL EN 14411:2012 H 附錄

### Commenti:

La modularità e le caratteristiche dimensionali delle piastrelle Ceramica Vogue presentano valori decisamente migliorativi rispetto alle prescrizioni delle norme, che ottimizzano il risultato estetico riducendo al contempo i costi di posa. Vogue è un prodotto facile da posare. I test relativi alle proprietà chimiche confermano che i prodotti di Ceramica Vogue forniscono prestazioni elevate per quanto riguarda la facilità di manutenzione, resistenza alle macchie, igienicità. In caso di particolari esigenze relative alla resistenza chimica, sono disponibili, a richiesta, test specifici.

### Comentarios:

La modularidad y las características de dimensión de los azulejos Ceramica Vogue presentan valores superiores y de excelencia respecto a los exigidos por las normas, optimizando así el resultado estético y reduciendo contemporaneamente los costes de aplicación. Ceramica Vogue es un producto de fácil aplicación. En los test relativos a las propiedades químicas se confirma que Cerámica Vogue tiene elevadas prestaciones por lo que se refiere a la facilidad de manutención, resistencia a las manchas e higienicidad. En casos de particulares exigencias relativas a la resistencia química disponemos, bajo pedido, de tests de superficie.

### Комментарий:

модульность и размерные свойства плитки Vogue показывают явно лучшие значения, чем требуют нормы. Таким образом, оптимизируется эстетический результат и в то же время снижается стоимость укладки. Плитка Vogue легко укладывается. Испытания, проведенные для определения химических свойств, показывают высокие результаты: легкий уход, устойчивость к пятнам, гигиеничность. В случае особых требований к химической устойчивости по запросу выдаются дополнительные результаты испытания.

### 附注:

Vogue 瓷磚所獨有的模塊和尺寸特徵已明顯的超越了標準慣例, 優化了美學效果的同時減少了安裝成本。Vogue 產品易於安裝。對產品化學特性的測試證實了 Vogue 產品的高性能使保養維護變得簡單, 抗, 維護衛生環境。並可以根據個案要求申請關於化學抵抗性的特殊檢測實驗。













## Dimensioni e qualità della superficie Dimensiones y calidad de la superficie

Размер и качественные показатели поверхности 尺寸和表面質量

formato nominale formato nominal номинальный формате 標準形狀	dimensione di fabbricazione formato de fabricación производственный размер 實際尺寸	metodo di prova método de prueba метод испытания 检测方法	requisiti requisitos реквизиты 需求		risultati Vogue resultados Vogue результаты Vogue Vogue 結果	
<b>5x5 cm</b>	lati - lados - стороны - 邊數: 48,1x48,1 mm	EN ISO 10545-2			lati - lados стороны - 邊數:	± 0,3 mm
	spessore - espesor - толщина - 厚度: 7 mm				spessore - espesor толщина - 厚度:	± 0,4 mm
<b>5x20 cm</b>	lati - lados - стороны - 邊數: 48,1x198,4 mm	EN ISO 10545-2	lati - lados стороны - 邊數:	± 0,6%	lati - lados стороны - 邊數:	± 0,3%
	spessore - espesor - толщина - 厚度: 7 mm		spessore - espesor толщина - 厚度:	± 5%	spessore - espesor толщина - 厚度:	± 4%
<b>5x40 cm</b>	lati - lados - стороны - 邊數: 48,1x398,8 mm	EN ISO 10545-2	lati - lados стороны - 邊數:	± 0,6%	lati - lados стороны - 邊數:	± 0,3%
	spessore - espesor - толщина - 厚度: 8,5 mm		spessore - espesor толщина - 厚度:	± 5%	spessore - espesor толщина - 厚度:	± 4%
<b>10x10 cm</b>	lati - lados - стороны - 邊數: 98,2x98,2 mm	EN ISO 10545-2	lati - lados стороны - 邊數:	± 0,9 mm	lati - lados стороны - 邊數:	± 0,3 mm
	spessore - espesor - толщина - 厚度: 7 mm		spessore - espesor толщина - 厚度:	± 0,5 mm	spessore - espesor толщина - 厚度:	± 0,4 mm
<b>10x20 cm</b>	lati - lados - стороны - 邊數: 98,2x198,4 mm	EN ISO 10545-2	lati - lados стороны - 邊數:	± 0,6%	lati - lados стороны - 邊數:	± 0,3%
	spessore - espesor - толщина - 厚度: 7 mm		spessore - espesor толщина - 厚度:	± 5%	spessore - espesor толщина - 厚度:	± 4%
<b>20x20 cm</b>	lati - lados - стороны - 邊數: 198,4x198,4 mm	EN ISO 10545-2	lati - lados стороны - 邊數:	± 0,6%	lati - lados стороны - 邊數:	± 0,3%
	spessore - espesor - толщина - 厚度: 7 mm		spessore - espesor толщина - 厚度:	± 5%	spessore - espesor толщина - 厚度:	± 4%
<b>20x40 cm</b>	lati - lados - стороны - 邊數: 198,4x398,8 mm	EN ISO 10545-2	lati - lados стороны - 邊數:	± 0,6%	lati - lados стороны - 邊數:	± 0,3%
	spessore - espesor - толщина - 厚度: 8,5 mm		spessore - espesor толщина - 厚度:	± 5%	spessore - espesor толщина - 厚度:	± 4%
<b>40x40 cm</b>	lati - lados - стороны - 邊數: 398,8x398,8 mm	EN ISO 10545-2	lati - lados стороны - 邊數:	± 0,6%	lati - lados стороны - 邊數:	± 0,3%
	spessore - espesor - толщина - 厚度: 8,5 mm		spessore - espesor толщина - 厚度:	± 5%	spessore - espesor толщина - 厚度:	± 4%
<b>Rettilineità dei lati (superficie di esercizio)</b> - Rectilineidad de los lados (superficie de servicio) - Прямолинейность сторон (рабочих поверхностей) - 直 线边 (场地表面)		EN ISO 10545-2	± 0,5%		± 0,4%	
<b>Ortogonalità</b> - ortogonalidad - ортогональность - 垂 直度		EN ISO 10545-2	± 0,5%		± 0,4%	
<b>Planarità della superficie</b> - planaridad - плоскостность поверхности - 平面度		EN ISO 10545-2	± 0,5%		± 0,4%	
<b>Qualità della superficie</b> - calidad de la superficie - качественные показатели поверхности - 表面質量		EN ISO 10545-2	min. 95%		min. 95%	



## Proprietà fisiche Características físicas Физические свойства 物理屬性

prova prueba испытание 檢測	metodo di prova método de prueba метод испытания 檢測方法	requisiti requisitos реквизиты 需求	risultati Vogue resultados Vogue результаты Vogue Vogue 結果
 massa d'acqua assorbita (%) - masa de agua absorbida (%) - масса поглощаемой воды в % - 吸水率 %	EN ISO 10545-3	$0,50\% < E_b \leq 3,00\%$	1,5 % (escluso pezzi speciali e bisello - excepción hecha para las piezas especiales y bisello - кроме специальных элементов и Bisello - 除 Bisello 外的配件)
 Resistenza di rottura Resistencia de rotura Прочность на разрыв 耐裂性	spessore - espesor - толщина 厚度: $\geq 7,5$ mm EN ISO 10545-4	1.100 N min.	> 1.700 N
	spessore - espesor - толщина 厚度: $< 7,5$ mm EN ISO 10545-4	700 N min.	> 1.000 N
 Modulo di rottura - Módulo de rotura - Модуль разрыва - 断裂模量	EN ISO 10545-4	30 N/mm <sup>2</sup> min.	> 40 N/mm <sup>2</sup>
 Resistenza all'abrasione (P.E.I.) - resistencia a la abrasión (P.E.I.) - сопротивляемость истиранию (P.E.I.) - 耐磨性 (P.E.I.)	EN ISO 10545-7	riportare la classe di abrasione - dar la clase de la abrasión - указать класс истирания - 磨損等級舉證	vedi pagina prodotto - véase la página del producto - см. страницу изделия - 见产品页
 Coefficiente di dilatazione termica lineare - coeficiente de dilatación térmica lineal - коэффициент линейного теплового расширения - 線性熱漲系數	EN ISO 10545-8	metodo di prova disponibile - método de prueba disponible - имеется испытательный метод - 可行的檢測方法	$< 6,9 \times 10^{-6} / ^\circ\text{C}$
 Resistenza agli sbalzi termici - resistencias a los choques térmicos - устойчивость к перепадам температуры - 抗熱衝擊性能	EN ISO 10545-9	metodo di prova disponibile - método de prueba disponible - имеется испытательный метод - 可行的檢測方法	garantita - garantizada - гарантировано - 允許
 Resistenza al cavillo - resistencia al cuarteado - сопротивляемость кракелюрам - 抗裂度	EN ISO 10545-11	richiesta - requerido - запрос - 要求	garantita - garantizada - гарантировано - 允許
 Resistenza al gelo - resistencia al hielo - морозостойкость - 抗凍性	EN ISO 10545-12	metodo di prova disponibile - método de prueba disponible - имеется испытательный метод - 可行的檢測方法	garantita (escluso pezzi speciali, bisello) - garantizada (excepción hecha para las piezas especiales, bisello) - гарантировано (кроме специальных элементов, Bisello) - 允許 (配件, bisello 配件除外)
 Dilatazione dovuta all'umidità - extensión a la humedad - расширение при воздействии влаги - 遇濕膨脹度	EN ISO 10545-10	metodo di prova disponibile - método de prueba disponible - имеется испытательный метод - 可行的檢測方法	< 0,04%
 Resistenza all'urto - resistencia al impacto - Устойчивость к удару - 抗衝擊性	EN ISO 10545-5	metodo di prova disponibile - método de prueba disponible - имеется испытательный метод - 可行的檢測方法	> 0,6 (vedi appendice P) - (vea el apéndice P) - (см. приложение P) - (參閱附錄P)

## Proprietà chimiche Características químicas Химические характеристики 化学特性

prova prueba испытание 檢測	metodo di prova método de prueba метод испытания 檢測方法	requisiti requisitos реквизиты 需求	risultati Vogue resultados Vogue результаты Vogue Vogue 結果
 Resistenza alle macchie - resistencia a las manchas - сопротивляемость пятнам - 抗性	EN ISO 10545-14	classe 3 min.	3 min (vedi appendice P) - (vea el apéndice P) - (см. приложение P) - (參閱附錄P)
 Resistenza ai prodotti chimici d'uso domestico ed agli additivi per piscina - resistencia a los productos químicos para la limpieza doméstica y para piscinas - сопротивляемость изделиям бытовой химии и добавкам к воде для бассейна - 對抗家政服務所需的化學產品和用於游泳池的添加劑。	EN ISO 10545-13	GB min.	GB min.
 Resistenza ad acidi e basi a bassa concentrazione - Resistencia a los ácidos y a las bases con baja concentración - Стойкость к кислотам и щелочам низкой концентрации - 耐低浓度酸和碱	EN ISO 10545-13	indicata dal produttore indicada por el fabricante указано производителем 生產者表明	GLB min.

## Proprietà chimiche Características químicas Химические характеристики 化学特性

	<b>Resistenza ad acidi e basi ad alta concentrazione</b> Resistencia a los ácidos y a las bases con alta concentración - Стойкость к кислотам и щелочам высокой концентрации 耐高浓度酸和碱	EN ISO 10545-13	<b>metodo di prova disponibile</b> método de prueba disponible имеется испытательный метод 可行的檢測方法	GHB min.
	<b>Cessione di piombo e cadmio - cesión de plomo y cadmio</b> - выделение свинца и кадмия - 鉛和的損耗	EN ISO 10545-15	<b>metodo di prova disponibile</b> método de prueba disponible имеется испытательный метод 可行的檢測方法	<b>disponibile a richiesta</b> - disponible si requerido - по запросу - 按需供貨

## Altre prove Otras pruebas Другие испытания 其他檢測

prova prueba испытание 檢測	metodo di prova método de prueba метод испытания 檢測方法	requisiti requisitos реквизиты 需求	resultati Vogue resultados Vogue результаты Vogue Vogue 結果	
	<b>Resistenza dei colori alla luce</b> - resistencia de los colores a la luz - устойчивость цветов к световому воздействию - 抗褪色	DIN 51094	<b>non previsto</b> - no previsión не предусмотрено - 無預期	<b>garantita</b> - garantizada - гарантировано - 允許
	<b>Reazione al fuoco</b> - reacción al fuego - реакция при контакте с огнём - 防火性	<b>senza prova sin prueba без испытания</b> 無檢測	<b>decisione 96/603/CE</b> decisión 96/603/CE - Решение 96/603/CE - 96/603/CE 決議	<b>classe A1</b>

## Determinazione della pulibilità e analisi microbatterica

I materiali di Ceramica Vogue, previa accurata pulizia con prodotti specifici, non favoriscono il proliferare dei batteri (prova di laboratorio disponibile).

## Determinación de la limpiabilidad y análisis microbacteriano

Los materiales de Ceramica Vogue, previa esmerada limpieza con productos específicos, no fomentan la proliferación bacteriana (disponible la prueba de laboratorio).

## Определение очищаемости и микробиологический анализ

Изделия Ceramica Vogue, после тщательной очистки с помощью специальных средств, не способствуют размножению бактерий (что подтверждается лабораторными исследованиями).

## 清潔性測定及微細菌分析

Ceramica Vogue所用材料如使用适当的清洁剂正确清洗, 不适于细菌的增殖(可进行实验室检测)。

## Conformità alla Normativa

Il materiale Ceramica Vogue (prima scelta) è conforme a quanto previsto dalla normativa UNI EN 14411-2012 - Appendice H. Il sistema di gestione applica quanto previsto dalle Norme della Serie ISO 9000, ISO 14000 e dal Regolamento CE761/2001 EMAS. L'intero ciclo produttivo è dotato di Autorizzazione Integrata Ambientale, ai sensi dell'art. 4 D.Lgs 372/99 (I.P.P.C)

## Conformidad con las Normas

El material de Ceramica Vogue (primera calidad) cumple con cuanto previsto por las normas UNI EN 14411-2012 - Apéndice H. El sistema de gestión pone en práctica cuanto previsto por las Normas de la Serie ISO 9000, ISO 14000 y por el Reglamento CE761/2001 EMAS. Todo el ciclo productivo cuenta con la Autorización Integrada Ambiental, con arreglo al art. 4 del D.Lgs italiano 372/99 (I.P.P.C)

## Соответствие нормативным требованиям

Изделия Ceramica Vogue (первый сорт) соответствуют нормативным требованиям, предусмотренным стандартом UNI EN 14411-2012 - Приложение H. Система управления применяет положения, предусмотренные Нормативами серии ISO 9000, ISO 14000 и Регламентом CE761/2001 EMAS. Весь производственный цикл имеет Комплексное экологическое разрешение согласно ст. 4 Законодательного декрета 372/99 (I.P.P.C – Комплексное предотвращение и контроль загрязнений)

## 合規性

Vogue瓷磚材料 (首選) 符合UNI EN14411-2012 - 附錄H的規定。其管理体系采用ISO 9000和ISO 14000系列标准及CE761/2001 EMAS规则。根据综合预防和降低污染 (I.P.P.C.) 法令372/99号第4条的规定, 整个生产过程都具有综合环境许可

## Appendice P Apéndice P Приложение P 附錄 P

**EN ISO 10545-5: Determinazione della resistenza all'impatto mediante la misurazione del coefficiente di restituzione:** Questa prova è destinata solo a prove su piastrelle che sono utilizzate in aree in cui la resistenza all'urto è considerata essere di particolare importanza. Il requisito normale per applicazioni sottoposte a basse sollecitazioni è un coefficiente di restituzione di 0,55. Per applicazioni sottoposte a sollecitazioni pesanti si richiederebbero valori più alti.

**EN ISO 10545-14: Determinazione della resistenza alle macchie:** La prova è obbligatoria per le piastrelle smaltate. Per le piastrelle non smaltate, se la macchiatura può costituire un problema, si raccomanda di consultare il fabbricante. Questo metodo non è inteso per le variazioni temporanee di colore che si possono verificare in certi tipi di piastrelle smaltate a causa dell'assorbimento di acqua nel supporto sotto lo smalto.

**EN ISO 10545-5: Determinación del impacto resistencia mediante medición del coeficiente de restitución:** Esta prueba va dirigida sólo a azulejos que se utilizan en áreas la resistencia a la abrasión de las cuales se considera de particular importancia. El requisito normal para aplicaciones expuestas a bajo tráfico es de un coeficiente de restitución de 0,55. Para aplicaciones en zonas de tráfico pesado se piden valores más altos.

**EN ISO 10545-14: Determinación de la resistencia a las manchas:** La prueba es obligatoria para los azulejos esmaltados. Para los azulejos no esmaltados, si la mancha pudiera constituir un problema, se recomienda consultar al fabricante. Este método no es inteso para las variaciones temporáneas de color que se pueden constatar en ciertos tipos de baldosas esmaltadas a causa de la absorción del agua en el soporte debajo del esmalte.

**EN ISO 10545-5: Определение сопротивляемости удару через измерение коэффициента отдачи:** это испытание состоит только тогда, когда сопротивляемость удару считается особенно важной. Нормальным значением для поверхностей, подчинённых слабому воздействию, является коэффициент отдачи 0,55. Для поверхностей, подчинённых более сильным воздействиям, потребуются значения повыше.

**EN ISO 10545-14: Определение сопротивляемости пятнам:** Испытание обязательно для эмалированной плитки. Для других видов плитки, если появление пятен может быть проблемой, советуем обращаться к производителю. Этот метод испытания не касается временного изменения цветов, которые могут происходить у некоторых видов эмалированной плитки из-за водопоглощения основы под эмалью.

**EN ISO 10545-5: 通過測量回彈系數的抗衝擊性測驗:** 這項檢測只針對於鋪設在對抗衝擊性有特別需要的區域的瓷磚。輕度使用區域的常規要求為0.55的恢復系數, 如重度使用則需要更高。

**EN ISO 10545-14: 耐漬性能檢測:** 對於釉面磚該檢測為強制性檢測。如果點成為未上釉瓷磚的問題請諮詢製造商。由於釉面下磚體吸水這個測試不被用於可能出現在某些釉面磚上的各種臨時顏色。

## Appendice N Aréndice N Приложение N 附錄 N

### Classificazione delle piastrelle smaltate per pavimento in base alla loro resistenza all'abrasione

Questa classificazione approssimativa viene fornita solo a scopo di guida (vedere ISO 10545-7). Non dovrebbe essere utilizzata per fornire prescrizioni di prodotto in relazione a requisiti particolari.

**Classe 0:** piastrelle in questa classe non sono consigliate per il rivestimento dei pavimenti

**Classe 1:** rivestimenti di pavimenti in aree soggette a calpestio con scarpe a suola morbida o a piedi nudi senza sporco abrasivo (per esempio bagni e camere da letto in edifici residenziali, senza accesso diretto dall'esterno).

**Classe 2:** Rivestimenti di pavimenti in aree soggette a calpestio con scarpe a suola morbida o normale con, tutt'al più, piccoli quantitativi occasionali di sporco abrasivo (per esempio stanze nelle zone giorno di abitazioni private, ad eccezione di cucine, ingressi ed altre stanze ad alto traffico). Questo non si applica nel caso di calzature non normali, quali ad esempio scarpe chiodate.

**Classe 3:** Rivestimenti di pavimenti in aree soggette a calpestio con scarpe normali e con presenza frequente di piccole quantità di sporco abrasivo (per esempio cucine di edifici residenziali, sale, corridoi, balconi, logge e terrazze). Questo non si applica nel caso di calzature non normali, quali ad esempio scarpe chiodate.

**Classe 4:** Rivestimenti di pavimenti in aree soggette a calpestio da traffico ordinario con sporco abrasivo, per cui le condizioni sono più severe di quelle riportate in classe 3 (per esempio ingressi, cucine commerciali, hotel, negozi ed aree vendita).

**Classe 5:** Rivestimenti di pavimenti soggetti a traffico pedonale intenso per periodi di tempo prolungati con sporco abrasivo, cosicché le condizioni sono le più severe nelle quali si possano utilizzare piastrelle smaltate per pavimento (per esempio aree pubbliche come centri commerciali, sale di aeroporti, ingressi di hotel, passaggi pedonali pubblici e applicazioni industriali).

Questa classificazione è valida per le applicazioni riportate in condizioni normali. Si dovrebbero prendere in considerazione le scarpe, il tipo di traffico ed i metodi di pulizia prevedibili, ed i pavimenti dovrebbero essere adeguatamente protetti dallo sporco abrasivo all'ingresso di edifici mediante interposizione di sistemi di pulizia delle scarpe. In casi estremi di traffico molto pesante e di abbondanza di sporco abrasivo, si possono prendere in considerazione piastrelle non smaltate per pavimento del gruppo I.

Clasificación de los azulejos esmaltados para suelos en base a la resistencia a la abrasión.

Esta clasificación es aproximativa y debe ser usada sólo como guía (ver ISO 10545-7). No debe ser utilizada para dar prescripciones del producto en relación a estos requisitos en particular.

**Clase 0:** No aconsejables para suelos.

**Clase 1:** Revestimiento de suelos en áreas sujetas a tráfico con zapatos de suela blanda o con pies descalzos sin suciedad abrasiva (p.e.: baños, habitaciones de edificios residenciales, sin acceso directo al exterior).

**Clase 2:** Revestimientos de suelos en áreas sujetas a tráfico con suelas blandas o normales con, a lo sumo, pequeñas cantidades ocasionales de suciedad abrasiva (p.e: salones en casas privadas a excepción de la cocina, entradas y otras habitaciones de tráfico elevado). Esta regla no es aplicable en el caso de calzado no normal, tal cual zapatos con clavos.

**Clase 3:** Revestimientos de suelos en áreas sujetas a tráfico con zapatos normales y con presencia frecuente de pequeñas cantidades de suciedad abrasiva (p.e. cocinas en edificios residenciales, salas, pasadizos, balcones y terrazas). Esta regla no es aplicable en el caso de calzado no normal, tal cual zapatos con clavos.

**Clase 4:** Revestimientos de suelos en áreas sujetas a tráfico ordinario con suciedad abrasiva, para las cuales las condiciones son mucho más severas de las que se exponen en la clase 3 (p.e.: entradas, cocinas industriales, hotel, tiendas y áreas de venta)

**Clase 5:** Revestimientos de suelos sujetos a tráfico peatonal intenso durante periodos de tiempo prolongados con suciedad abrasiva, de manera tal que las condiciones son lo más severas en las cuales se pueden utilizar los azulejos esmaltados para suelos (p.e: áreas públicas como centros comerciales, salas de los aeropuertos, ingresos de hoteles, pasos peatonales públicos y aplicaciones industriales).

Esta clasificación es válida para las aplicaciones que se describen y en condiciones normales. Se deberían tomar en consideración los zapatos, el tipo de tráfico y los métodos de limpieza previstos. Los suelos deberían estar adecuadamente protegidos de la suciedad abrasiva en la entrada de los edificios mediante la interposición de sistemas para la limpieza de los zapatos. En casos extremos de tráfico muy pesado y de abundancia de suciedad abrasiva se pueden tomar en consideración los azulejos no esmaltados para suelos del Grupo I.

Классификация напольной эмалированной плитки по отношению устойчивости к истиранию.

Эта классификация приближительна и выдаётся для информации (смотри ISO 10545-7). Если есть определенные требования к продукту, не используйте эту классификацию.

**Класс 0:** Плитка этого типа не рекомендуется для покрытия полов.

**Класс 1:** Покрытия полов в зонах, на которые наступают голыми ногами или мягкой обувью, без абразивной грязи (например, в ванных и в спальнях жилых домов, в зонах, где нет прямого доступа с улицы).

**Класс 2:** Покрытия полов в зонах, на которые наступают мягкой или обычной обувью, с, возможно, иногда небольшим количеством абразивной грязи (например, в гостиной частных домов, но не на кухне, не в прихожей или в помещениях с большой проходимостью). Это не годится в случае, если используются необычные виды обуви как, например, шипованная обувь.

**Класс 3:** Покрытия полов в зонах, на которые наступают обычной обувью с небольшим количеством абразивной грязи (например на кухнях жилых домов, в залах, в коридорах, на балконах, лоджиях и террасах). Это не годится в случае, если используются необычные виды обуви такие как шипованная обувь.

**Класс 4:** Покрытия полов в помещениях с умеренной проходимостью и с абразивной грязью, в наиболее тяжёлых условиях, чем Classe 3 (например, в прихожих, на кухнях ресторанов, в отелях, в магазинах и торговых площадях).

**Класс 5:** Покрытия полов в помещениях с большой проходимостью и с абразивной грязью, в самых тяжёлых условиях, при которых можно использовать эмалированную плитку (например, в общественных местах, как торговые центры, залы аэропортов, входы отелей, общественные пешеходные проходы и промышленные помещения).

Эта классификация действует в обычных условиях. Надо принимать во внимание вид обуви, тип трафика и методы очистки. Полы должны быть надлежащим образом защищены от абразивной грязи, устанавливая у входа в здание системы очистки обуви. В крайних случаях интенсивного трафика и абразивной грязи, Вы можете рассмотреть возможность, использовать неэмалированную плитку для пола группы I.

釉面地磚根據其耐磨性進行分類。

這個大致的分類表可以作為一個指南。(參閱 ISO10545-7)它不適用於特殊要求的產品價例。

**級別 0:** 該等級瓷磚不建議用於樓面覆蓋。

**級別 1:** 該等級瓷磚適用於赤或穿著無粗粒垢的軟底鞋的走動區域。(如沒有外來人員進入的住宅的浴室或臥室)

**級別 2:** 該等級瓷磚用於穿軟底鞋或普通鞋或許沾有少量粗粒垢的地面使用。(如除去廚房, 入口處和其他高流量房間的私人住宅)。此系列對於非一般鞋類並不適用如飾釘類鞋。



**級別 3:** 該等級用於普通鞋類頻繁出入並沾有許多粗粒垢的樓面覆蓋層使用。(如住宅區的廚房, 客廳, 門廳, 陽台, 走廊和露台) 此系列對於非一般鞋類並不適用如飾釘類鞋。

**級別 4:** 該等級用於日常人流量且帶有粗粒垢的地面區域使用, 即可以承受比級別 3 更差的情況。(如門廳, 商業廚房, 酒店, 商店和售賣區)



**級別 5:** 該等級用於長期人流量大且帶有粗粒垢的地面區域使用, 所以此系列是可用的釉面瓷磚所能承受的最大極限。(例如公共區域像商業中心, 機場大廳, 賓館入口, 公共人行橫道和工業應用公司)

該分類等級適用於標準條件的應用。鞋子, 交通情況和已知清潔制度都應參考在內而且應通過樓宇入口處的鞋類清潔系統避免粗粒垢被帶入從而適當的保護地板免於垢的侵蝕。在最高人流量和粗粒垢最多的區域, 可酌情使用非釉面地磚。

### Vogue System Flooring R10 B (A+B)

prova prueba испытание 檢測	metodo di prova método de prueba метод испытания 檢測方法	requisiti requisitos реквизиты 需求				resultati Vogue resultados Vogue результаты Vogue Vogue 結果
 <p>determinazione proprietà antiscivolo: determinación de las propiedades antideslizantes: определение уровня противоскольжения: 防滑特性的檢測:</p>	<p>DIN 51130 grado scivolosità grado de adherencia уровень скольжения 防滑特證</p>	<p><b>R9</b> aderenza normale adherencia normal нормальное сцепление 一般附着力</p>	<p><b>R10</b> aderenza media adherencia media среднее сцепление 中等附着力</p>	<p><b>R11</b> aderenza elevata alta adherencia высокое сцепление 高度附着力</p>	<p><math>\alpha</math> = angolo di inclinazione ángulo de la inclinación угол наклона 傾斜角</p>	<p>R10</p>
		<p><math>6^\circ \leq \alpha \text{ tot} \leq 10^\circ</math></p>	<p><math>10^\circ \leq \alpha \text{ tot} \leq 19^\circ</math></p>	<p><math>19^\circ \leq \alpha \text{ tot} \leq 27^\circ</math></p>		
 <p>determinazione proprietà antiscivolo di zone bagnate a piedi nudi: determinación de las propiedades antideslizantes en zonas mojadas con piés descalzos: определение уровня противоскольжения влажной поверхности босиком: 赤在潮濕區域的防滑特性檢測:</p>	<p>DIN 51097 angolo inclinazione (°) ángulo de inclinación (°) угол наклона (°) 傾斜角(°)</p>	<p><b>A</b> aderenza media adherencia media среднее сцепление 中等附着力</p>	<p><b>B</b> aderenza elevata alta adherencia высокое сцепление 高度附着力</p>	<p><b>C</b> aderenza forte adherencia fuerte сильное сцепление 強附着力</p>		<p>B (A+B)</p>
		<p><math>\geq 12 &lt; 18</math></p>	<p><math>\geq 18 &lt; 24</math></p>	<p><math>\geq 24</math></p>		
<p>coefficiente di attrito: (1) asciutto (cuoio)   (2) bagnato (gomma) coeficiente de fricción: 1. seco (cuero)   2. mojado (caucho) коэффициент трения: 1. Сухая поверхность (кожа)   2. Мокрая поверхность (резина) 摩擦系數: 1.乾燥 (皮革)   2.潮濕 (橡膠)</p>	<p>B.C.R.A.</p>	<p><math>\mu \leq 0,19</math> scivolosità pericolosa deslizamiento peligroso опасное скольжение 危險的防滑性</p>	<p><math>0,20 \leq \mu \leq 0,39</math> scivolosità eccessiva deslizamiento excesivo резмерное скольжение 最大程度的防滑性</p>	<p><math>0,40 \leq \mu \leq 0,74</math> attrito soddisfacente fricción satisfactoria удовлетворительное трение 符合的假想</p>	<p><math>\mu \geq 0,75</math> attrito eccellente fricción excelente трение оптимальное 出色的假想</p>	<p>(1) <math>\mu &gt; 0,48</math> (2) <math>\mu &gt; 0,42</math></p>

### Vogue System Grip R11 C (A+B+C)

prova prueba испытание 檢測	metodo di prova método de prueba метод испытания 檢測方法	requisiti requisitos реквизиты 需求				resultati Vogue resultados Vogue результаты Vogue Vogue 結果
 <p>determinazione proprietà antiscivolo: determinación de las propiedades antideslizantes: определение уровня противоскольжения: 防滑特性的檢測:</p>	<p>DIN 51130 grado scivolosità grado de adherencia уровень скольжения 防滑特證</p>	<p><b>R9</b> aderenza normale adherencia normal нормальное сцепление 一般附着力</p>	<p><b>R10</b> aderenza media adherencia media среднее сцепление 中等附着力</p>	<p><b>R11</b> aderenza elevata alta adherencia высокое сцепление 高度附着力</p>	<p><math>\alpha</math> = angolo di inclinazione ángulo de la inclinación угол наклона 傾斜角</p>	<p>R11</p>
		<p><math>6^\circ \leq \alpha \text{ tot} \leq 10^\circ</math></p>	<p><math>10^\circ \leq \alpha \text{ tot} \leq 19^\circ</math></p>	<p><math>19^\circ \leq \alpha \text{ tot} \leq 27^\circ</math></p>		
 <p>determinazione proprietà antiscivolo di zone bagnate a piedi nudi: determinación de las propiedades antideslizantes en zonas mojadas con piés descalzos: определение уровня противоскольжения влажной поверхности босиком: 赤在潮濕區域的防滑特性檢測:</p>	<p>DIN 51097 angolo inclinazione (°) ángulo de inclinación (°) угол наклона (°) 傾斜角(°)</p>	<p><b>A</b> aderenza media adherencia media среднее сцепление 中等附着力</p>	<p><b>B</b> aderenza elevata alta adherencia высокое сцепление 高度附着力</p>	<p><b>C</b> aderenza forte adherencia fuerte сильное сцепление 強附着力</p>		<p>C (A+B+C)</p>
		<p><math>\geq 12 &lt; 18</math></p>	<p><math>\geq 18 &lt; 24</math></p>	<p><math>\geq 24</math></p>		
<p>coefficiente di attrito: (1) asciutto (cuoio)   (2) bagnato (gomma) coeficiente de fricción: 1. seco (cuero)   2. mojado (caucho) коэффициент трения: 1. Сухая поверхность (кожа)   2. Мокрая поверхность (резина) 摩擦系數: 1.乾燥 (皮革)   2.潮濕 (橡膠)</p>	<p>B.C.R.A.</p>	<p><math>\mu \leq 0,19</math> scivolosità pericolosa deslizamiento peligroso опасное скольжение 危險的防滑性</p>	<p><math>0,20 \leq \mu \leq 0,39</math> scivolosità eccessiva deslizamiento excesivo резмерное скольжение 最大程度的防滑性</p>	<p><math>0,40 \leq \mu \leq 0,74</math> attrito soddisfacente fricción satisfactoria удовлетворительное трение 符合的假想</p>	<p><math>\mu \geq 0,75</math> attrito eccellente fricción excelente трение оптимальное 出色的假想</p>	<p>(1) <math>\mu &gt; 0,70</math> (2) <math>\mu &gt; 0,58</math></p>

Vogue System Flooring40 R10

prova prueba испытание 檢測	metodo di prova método de prueba метод испытания 檢測方法	requisiti requisitos реквизиты 需求				risultati Vogue resultados Vogue результаты Vogue Vogue 結果
 determinazione proprietà antiscivolo: determinación de las propiedades antideslizantes: определение уровня противоскольжения: 防滑特性的檢測:	DIN 51130 grado scivolosità grado de adherencia уровень скольжения 防滑特證	R9 aderenza normale adherencia normal среднее сцепление 一般附着力	R10 aderenza media adherencia media среднее сцепление 中等附着力	R11 aderenza elevata alta adherencia высокое сцепление 高度附着力	$\alpha$ = angolo di inclinazione ángulo de la inclinación угол наклона 傾斜角	R10
		$6^\circ \leq \alpha \text{ tot} \leq 10^\circ$	$10^\circ \leq \alpha \text{ tot} \leq 19^\circ$	$19^\circ \leq \alpha \text{ tot} \leq 27^\circ$		

Vogue System Grip40 B (A+B)

prova prueba испытание 檢測	metodo di prova método de prueba метод испытания 檢測方法	requisiti requisitos реквизиты 需求			risultati Vogue resultados Vogue результаты Vogue Vogue 結果
 determinazione proprietà antiscivolo di zone bagnate a piedi nudi: determinación de las propiedades antideslizantes en zonas mojadas con piés descalzos: определение уровня противоскольжения влажной поверхности босиком: 赤在潮濕區域的防滑特性檢測:	DIN 51097 angolo inclinazione (°) ángulo de inclinación (°) угол наклона (°) 傾斜角(°)	A aderenza media adherencia media среднее сцепление 中等附着力	B aderenza elevata alta adherencia высокое сцепление 高度附着力	C aderenza forte adherencia fuerte сильное сцепление 強附着力	B (A+B)
		$\geq 12 < 18$	$\geq 18 < 24$	$\geq 24$	

Vogue Pool Bump C (A+B+C) V6

prova prueba испытание 檢測	metodo di prova método de prueba метод испытания 檢測方法	requisiti requisitos реквизиты 需求				risultati Vogue resultados Vogue результаты Vogue Vogue 結果
 determinazione proprietà antiscivolo di zone bagnate a piedi nudi: determinación de las propiedades antideslizantes en zonas mojadas con piés descalzos: определение уровня противоскольжения влажной поверхности босиком: 赤在潮濕區域的防滑特性檢測:	DIN 51097 angolo inclinazione (°) ángulo de inclinación (°) угол наклона (°) 傾斜角(°)	A aderenza media adherencia media среднее сцепление 中等附着力	B aderenza elevata alta adherencia высокое сцепление 高度附着力	C aderenza forte adherencia fuerte сильное сцепление 強附着力	C (A+B+C)	
		$\geq 12 < 18$	$\geq 18 < 24$	$\geq 24$		
 valutazione dello spazio di dislocazione evaluación del espacio de dislocación оценка пространства размещения 安置地点的評估	DIN 51130 volumen cavità deflusso (cm <sup>3</sup> /dm <sup>2</sup> ) Volumen cavidad flujo Объем выпускной полости 排泄管道体积	V4 4 cm <sup>3</sup> /dm <sup>2</sup>	V6 6 cm <sup>3</sup> /dm <sup>2</sup>	V8 8 cm <sup>3</sup> /dm <sup>2</sup>	V10 10 cm <sup>3</sup> /dm <sup>2</sup>	V6



## ASTM Test Results

Test	Test methods	Requirements	Vogue results
 Water absorption (%)	C 373	0,5% to 3%	1,5 %
 Breaking strenght in N	C 648	≥ 250 lbf	> 265 lbf
 Chemical resistance	C 650	No requirement	Pass
 Stain resistance	C 1378	Pass	Pass
 Crazing resistance	C 424	Pass	Pass
 Frost resistance	C 1026:2013	As reported	Pass
 Bond strength of ceramic tile to portland cement	C 482 - 02 (2009)	> 0,34 MPa	1,41 MPa fibre glass mesh mounted
			1,32 MPa fibre glass not mesh mounted
 Thermal shock	C484	No sample must show visible effects	Pass

## Vogue System Flooring R10 B (A+B)

Test	Test methods	Requirements	Vogue results
Dry Coefficient of friction	C 1028	anti slip > 0,60	0,77
Wet Coefficient of friction	C 1028	anti slip > 0,60	0,68

## Vogue System Grip R11 C (A+B+C)

Test	Test methods	Requirements	Vogue results
Dry Coefficient of friction	C 1028	anti slip > 0,60	0,71
Wet Coefficient of friction	C 1028	anti slip > 0,60	0,79

## Marcatura CE

Il Regolamento Europeo 305/2011 (CPR) abroga la Direttiva 89/106/CEE sui prodotti da costruzione (CPD) introducendo dal 01/07/2013 alcune importanti novità nell'ambito della Marcatura CE dei prodotti da costruzione.

La Dichiarazione di Conformità dei prodotti da costruzione viene sostituita dalla Dichiarazione di Prestazione (DoP) con diverso significato e contenuto.

In assenza di questa dichiarazione i prodotti non possono circolare all'interno dei confini dell'Unione Europea.

La presenza del marchio CE su tutti gli imballi di Ceramica Vogue attesta che, il prodotto in essi contenuto è conforme a quanto dichiarato nelle schede tecniche, e la costanza delle prestazioni del prodotto è stata verificata ed attestata a garanzia dell'utilizzatore.

## Marcado CE

El Reglamento Europeo 305/2011 (CPR) abroga la Directiva 89/106/CEE referente a los productos de construcción (CPD) introduciendo, a partir del 01/07/2013 algunas novedades importantes en el ámbito del Mercado CE de los productos de construcción.

La Declaración de Conformidad de los productos de construcción es reemplazada por la Declaración de Prestaciones (DoP) con un significado y un contenido diferentes.

A falta de dicha declaración los productos no pueden circular dentro de las fronteras de la Unión Europea.

La presencia de la marca CE en todos los embalajes de Ceramica Vogue certifica que el producto que contienen es conforme con cuanto declarado en las fichas técnicas, y la constancia de las prestaciones del producto ha sido comprobada y certificada para la tutela del usuario.

## Маркировка CE

Европейский Регламент 305/2011 (CPR) отменяет Директиву 89/106/CEE в отношении строительных материалов (CPD), вводя с 01/07/2013 некоторые важные нововведения в область Маркировки CE строительных материалов.

Декларация соответствия строительных материалов заменяется Декларацией характеристик (DoP) с другим значением и содержанием.

В отсутствие этой декларации продукция не может обращаться в пределах Европейского Союза.

Наличие маркировки CE на всех упаковках Ceramica Vogue подтверждает, что изделия, содержащиеся в упаковке, соответствуют тому, что заявлено в технических паспортах, а неизменность характеристик изделий была проверена и подтверждена для обеспечения гарантии потребителям.

## CE标记

欧盟法规305/2011 (CPR) 废除了关于建筑产品的89/106/CEE法令 (CPD) , 并从2013年7月1日起增加了一些关于建筑产品 CE 标准方面重要的新规定。

建筑产品的合规性声明被以含有不同意义和内容的性能声明 (DoP) 取代。

如果不具备此声明, 产品不得在欧共同体国家范围内流通。

所有Vogue瓷砖材料包装上具有的 CE 标志, 证明所含产品与技术信息卡上说明的情况相符, 为了确保用户的利益, 产品恒定的性能已经核实和认证。

## Manutenzione e pulizia

La qualità di un rivestimento in piastrelle ceramiche dipende, oltre che da una buona progettazione e da una corretta posa, anche dalla cura che verrà rivolta alle superfici.

Le piastrelle Ceramica Vogue in grès smaltato in pasta bianca ingelivo sono resistenti, igieniche e facili da pulire, non richiedono particolari cure ma solo l'applicazione di alcune elementari norme di pulizia.

È importante distinguere tra pulizia di fine cantiere e pulizia ordinaria.

### PULIZIA DI FINE CANTIERE

Oltre a mantenere sempre protette le superfici durante la fase di cantiere, è di fondamentale importanza curare la prima pulizia. Questa operazione ha lo scopo di eliminare ogni traccia e residuo di posa dalla superficie delle piastrelle. Prima del lavaggio è importante rimuovere con un aspiratore lo sporco grossolano evitando di rigare la superficie delle piastrelle. La pulizia deve essere fatta con prodotti in commercio tipo Deterdek ([www.filachim.com](http://www.filachim.com)), Keranet ([www.mapei.com](http://www.mapei.com)) o prodotti similari.

Si raccomanda di seguire rigorosamente le indicazioni riportate sulle schede tecniche dei prodotti utilizzati e comunque di fare delle prove dei prodotti di pulizia su una piccola porzione di una piastrella prima di eseguire la pulizia totale della superficie.

### PULIZIA ORDINARIA

Per la pulizia ordinaria è bene usare prodotti in grado di eliminare eventuali macchie di sporco senza però intaccare la smaltatura superficiale, evitare quindi sostanze molto aggressive quali prodotti a base acida.

Usare semplici prodotti adatti alla pulizia della ceramica. Per migliorare l'efficacia dei detergenti diluirli con acqua calda.

### NORME GENERALI

Sostanze abrasive o strumenti per la pulizia quali spugne abrasive o spazzole eccessivamente dure sono sconsigliati in quanto potrebbero provocare sulla superficie delle piastrelle graffi o segni impossibili poi da eliminare.

Sui prodotti con caratteristiche antiscivolo evitare assolutamente l'utilizzo di prodotti lavaincera o cere.

Nel caso di locali comunicanti con l'esterno è indispensabile utilizzare zerbini per ridurre l'apporto di agenti abrasivi.

## Mantenimiento y limpieza

La calidad de un revestimiento de baldosas cerámicas depende no sólo de una buena proyección y de una correcta colocación sino también del cuidado dedicado a las superficies.

Las baldosas de gres esmaltado en pasta blanca anti hielo Ceramica Vogue son resistentes, higiénicas y fáciles de limpiar, y no requieren cuidados especiales sino sólo la aplicación de algunas reglas de limpieza elementales.

Es importante distinguir entre limpieza de fin de obra y limpieza ordinaria.

### LIMPIEZA DE FIN DE OBRA

Además de mantener siempre protegidas las superficies durante las fases de obra, es fundamental realizar correctamente la primera limpieza.

Esta operación sirve para eliminar cualquier resto o residuo de colocación de la superficie de las baldosas. Antes del lavado, es importante eliminar la suciedad gruesa con una aspiradora, evitando rayar la superficie de las baldosas. La limpieza debe realizarse con productos comerciales tipo Deterdek ([www.filachim.com](http://www.filachim.com)), Keranet ([www.mapei.com](http://www.mapei.com)) o afines.

Se recomienda seguir estrictamente las indicaciones que figuran en las etiquetas técnicas de los productos y realizar pruebas preliminares con los productos de limpieza sobre una pequeña porción de baldosa antes de proceder a la limpieza de toda la superficie.

### LIMPIEZA ORDINARIA

Para la limpieza ordinaria conviene utilizar productos adecuados para eliminar las manchas de suciedad sin mellar el esmalte superficial. Evitar las sustancias muy agresivas, como los productos de base ácida.

Utilizar simplemente productos adecuados para la limpieza de cerámica. Para mejorar la eficacia de los detergentes, diluirlos con agua caliente.

### NORMAS GENERALES

No utilizar sustancias abrasivas o herramientas de limpieza como esponjas abrasivas o cepillos demasiado duros, ya que podrían originar en la superficie de las baldosas rayas o marcas imposibles de eliminar.

Evitar en absoluto la aplicación de ceras o productos de lavado y encerado en baldosas con propiedades antideslizantes.

En los ambientes comunicados con el exterior es indispensable utilizar felpudos para limitar la introducción de agentes abrasivos.

## Уход

Качество облицовки из керамической плитки зависит не только от хорошо разработанного проекта, но и от надлежащего выполнения укладки, а также от ухода за поверхностями.

Плитка Ceramica Vogue морозоустойчивая из керамического гранита на основе белой глины, отличается прочностью, гигиеничностью, легко очищается элементарными средствами, не требуя специального ухода. Следует различать очистку после завершения строительства и регулярный уход.

### ОЧИСТКА ПОСЛЕ ЗАВЕРШЕНИЯ СТРОИТЕЛЬСТВА

При проведении строительных работ поверхности всегда должны быть защищены покрытием, кроме того, чрезвычайную важность представляет процедура первичной очистки.

В ходе данной операции с поверхности плитки удаляются все следы и остатки строительных материалов, использованных при укладке. Перед мытьём необходимо удалить крупные загрязнения при помощи пылесоса, стараясь не поцарапать поверхность плитки. Очистка должна производиться с использованием средств бытовой химии типа Deterdek ([www.filachim.com](http://www.filachim.com)), Keranet ([www.mapei.com](http://www.mapei.com)) или схожих с ними по свойствам.

Следует строго следовать указаниям, приведённым в описаниях используемых средств, перед началом очистки всей поверхности нужно опробовать чистящее средство на небольшом участке плитки.

### РЕГУЛЯРНАЯ ОЧИСТКА

Для регулярного ухода рекомендуется использовать моющие средства, способные удалять пятна загрязнений, не повреждая при этом поверхность глазури, соответственно, не следует применять слишком агрессивные вещества, в частности - продукты на кислотной основе.

Для очистки следует применять обычные средства для ухода за керамикой. Для более эффективного действия моющих средств их нужно разводить в горячей воде.

### ОБЩИЕ ПОЛОЖЕНИЯ

Не рекомендуется использовать для очистки абразивные средства или инструменты, такие как грубые абразивные мочалки или слишком жёсткие щётки, поскольку они могут поцарапать поверхность плитки и оставить невыводимые следы.

Ни в коем случае нельзя наносить на противоскользящие покрытия воскодержающие моющие средства или натирать их воском.

В помещениях с выходом наружу необходимо использовать коврики для предотвращения истирания.

## 保养和清理

一种使用瓷砖覆盖的表层的质量除了取决于良好的设计和正确的操作外,还取决于其后对表面的保养。瓷砖CERAMICA Vogue白色耐霜冻的玻璃釉陶非常扎实卫生,易清洗,不需特殊保养但应遵守某些最基本的清洁规则。

重要的是将工程结束时的清理与日常清洁区别开。

### 工程结束时的清理

除了在工程进展过程中一直对表面进行保护外,注重首次清理具有关键性的意义。

这一操作的目的是去除在安装瓷砖时留下的任何痕迹和残余物。在清洗之前,首先用一个吸尘器初步清理污物非常重要,应避免划伤瓷砖的表面。清理工作应使用市场上的Deterdek类([www.filachim.com](http://www.filachim.com)), Keranet([www.mapei.com](http://www.mapei.com))或类似产品。

请严格遵守所使用产品的技术说明书中的要求进行操作,并应在清洁整个表面之前,在小面积的瓷砖上进行试验。

### 常规清洁

常规清洁应使用能够去除污迹而不破坏表面釉质的产品,避免使用含强腐蚀性物质的产品,比如含酸产品。

使用适合陶瓷清理的普通产品。为了提高清洁剂的效力,可用热水稀释。

### 普通规则

用于清洁工作的磨蚀材料或工具,比如研磨海绵或过硬的刷子不宜使用,因为它们可能造成瓷砖表面的划痕或无法去除的痕迹。

对于具有防滑特性的产品,应绝对禁止使用含蜡产品或石蜡。

如果是与外界相通的场所,需使用擦鞋垫,以便减少磨蚀成分的携带。

## Pezzi Speciali Piezas especiales Специальные элементы 特殊配件

**Quadra 2,5x20**

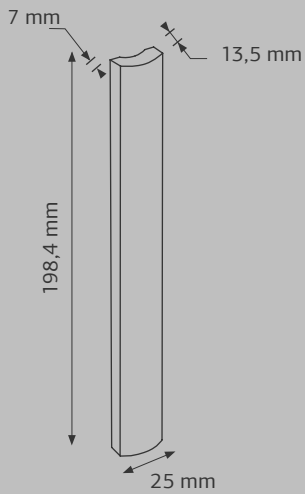

**Stick 1,2x20**

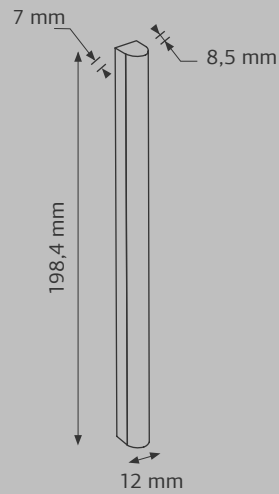

**cod. M 2,5x20**

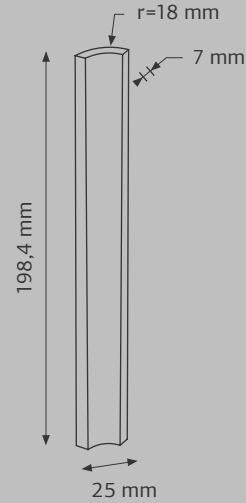

**cod. N 2,5x20**

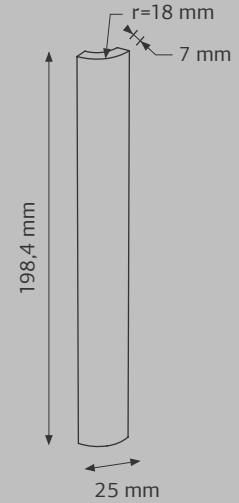

**cod. W 2,5x10**

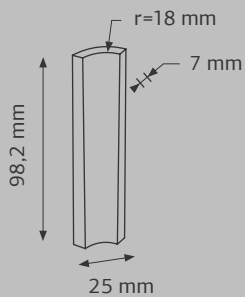

**cod. K 2,5x10**

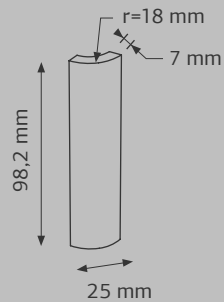

**cod. G 2,5x10**

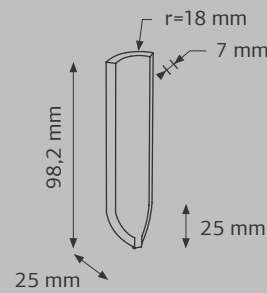

**cod. H 2,5x10**

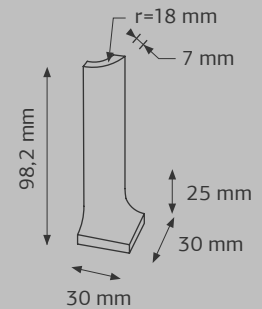

**cod. C 2,5x2,5**

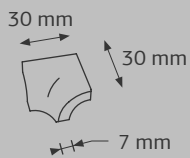

**cod. D 2,5x2,5**

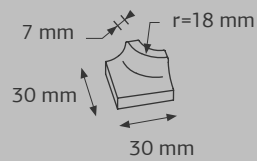

**cod. F 2,5x2,5**

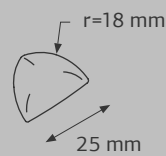

**cod. E 2,5x2,5**

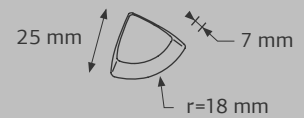

**cod. X 10x20**

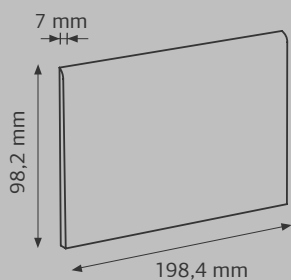

**cod. U 10x10**

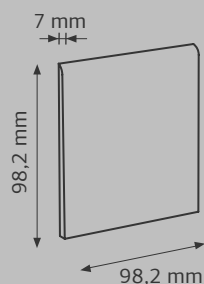

**Battiscopa 9,5x40**

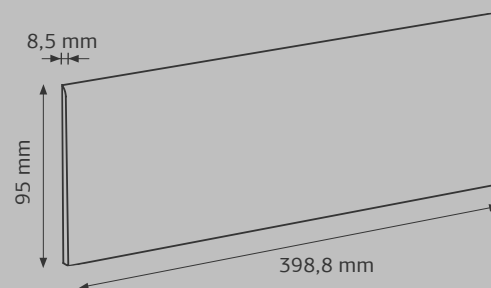

**Pezzi Speciali Piezas especiales Специальные элементы 特殊配件**

**cod. I 10x20**

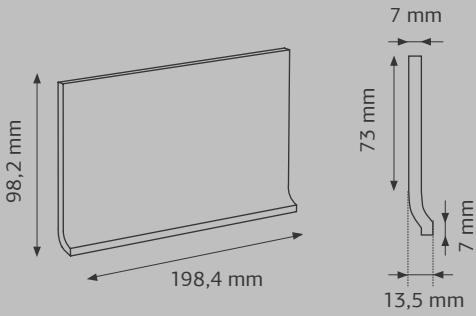

**cod. Z 10x10**

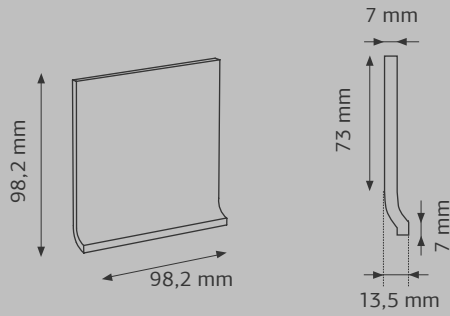

**Bordo cod. B 10x10**

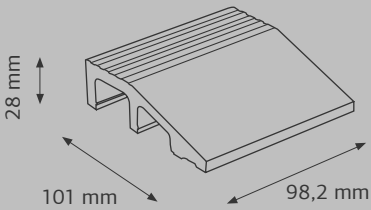

**Spigolo cod. E 10x10**

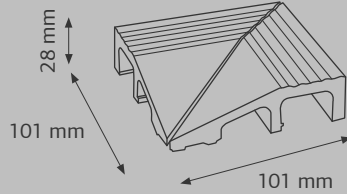

**Angolo cod. I 10x10**

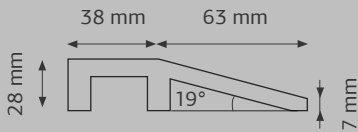
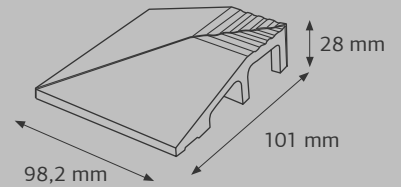

**Special Pool Special Pool Special Pool Special Pool**

**cod. BR 6,3x20**

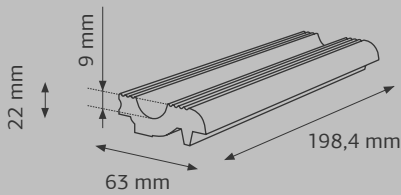

**cod. FU 4,5x20**

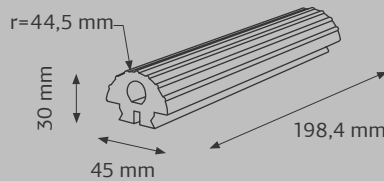

**cod. BC 10x20**

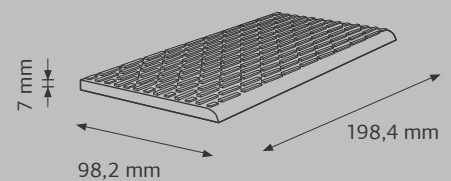

**cod. BR1 6,3x10**

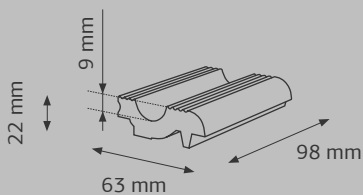

**cod. FU1 4,5x10**

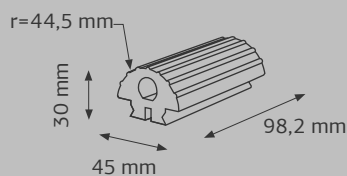

**cod. BC1 10x10**

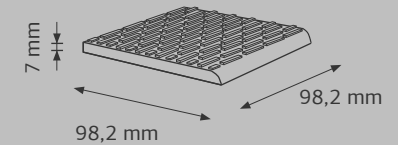



**Fotografi:**

MARTIN ARGYROGLO  
LUCIANO BUSANI  
ELSKE PHOTOGRAPHY  
DANIEL HOPKINSON - AHR  
LUKAS HUNEKE  
WALTER LUTTENBERGER  
MECCANICHE CREATIVE  
LUCA MORETTO  
NABITO ARCHITECTS  
ALBERTO NOVELLI  
PAOLA PANSINI  
CAROLA RIPAMONTI  
SANCEZ Y MONTORO

**Progetto:**



**Realizzazione:**

Ufficio marketing interno

**Stampa:**

Arti Grafiche Biellesi - Candelo (BI)

**Ufficio stampa:**

info@sabrinagiacchetti.it

Stampato in Italia - Giugno 2016



[www.ceramicavogue.it](http://www.ceramicavogue.it)

MADE IN ITALY

**Ceramica VOGUE**

è un marchio di

altaeco

GRUPPO INDUSTRIALE



Socio Ordinario  
del GBC Italia



Ceramics of Italy

**UFFICI e PRODUZIONE:**

SS 143 Loc. Vergnasco - 13882 Cerrione (BI) ITALIA  
tel. +39.015.672.1 - fax Italia +39.015.671.626  
fax Export +39.015.671.352  
e-mail: info@cervogue.com

**ПРЕДСТАВИТЕЛЬСТВО В РОССИИ:**

117292 Москва ул. Дмитрия Ульянова, д.16, к.2, оф. 249  
тел. +7 (495) 7249354 - 974 1692 - факс +7 (495) 5434261  
e-mail: russia@altaeco.com



[www.ceramicavogue.it](http://www.ceramicavogue.it)

**MADE IN ITALY**