

slabs

APAVISA

There are no limits to space,  
there are no limits to design.

# Index

## **160x320 cm**

---

Ocean Blue 10

## **120x260 cm**

---

Wild Forest 24

Borghini 40

Elegance 50

Statuario 60

Tattoo 82

Instinto 104

Equinox 128

Pietra grey 148

St. Vincent 162

Junoon 176

Calacatta Lincoln 194

Super White 200

Agata Blue 206

## **Technical information**

---

Technical information 212

# Sizes

slabs

**Floor & Walls**  
6 mm

**Floor & Walls**  
6 mm

**Floor & Walls**  
7 mm

**Non-slip**  
7 mm

**Outdoor**  
20 mm

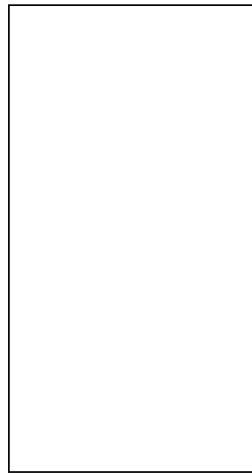

**160x320**  
160 x 320 cm  
62.99" x 125.98"

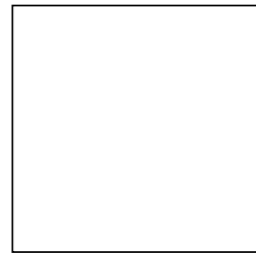

**160x160**  
160 x 160 cm  
62.99" x 62.99"



**80x160**  
80 x 160 cm  
31.49" x 62.99"

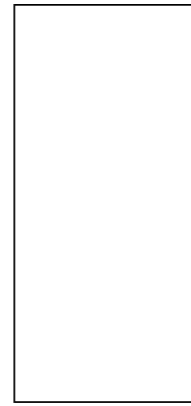

**120x260**  
119,3 x 260,0 cm  
46.97" x 102.4"



**60x260**  
59,55 x 260,0 cm  
23.45" x 102.4"

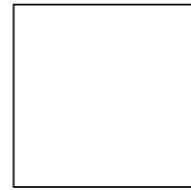

**120x120**  
119,3 x 119,3 cm  
46.97" x 46.97"



**60x120**  
59,55 x 119,3 cm  
23.45" x 46.97"

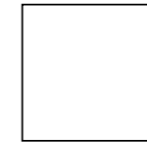

**90x90**  
89,46 x 89,46 cm  
35.22" x 35.22"



**45x90**  
44,63 x 89,46 cm  
17.57" x 35.22"

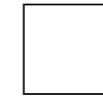

**60x60**  
59,55 x 59,55 cm  
23.45" x 23.45"



**30x60**  
29,75 x 59,55 cm  
11.71" x 23.45"



**30x60**  
29,75 x 59,55 cm  
11.71" x 23.45"

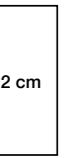

**50x100**  
49,75 x 99,55 cm  
19.59" x 39.19"

# Finishes

Polished



Lappato



Natural



Rescato





80 cm  
31,49"

160 cm  
62,99"

320 cm  
125,98"

160 cm  
62,99"

# Ocean Blue

Ocean Blue  
Polished

# Ocean Blue

Floor & walls  
Polished 6mm

Polished 7,4mm

Decor 7,4mm



**160x320**  
160 x 320 cm  
62.99" x 125.98"

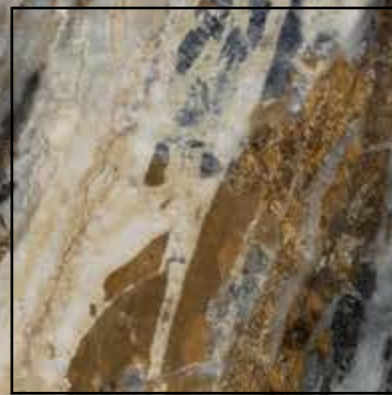

**160x160**  
160 x 160 cm  
62.99" x 62.99"



**80x160**  
80 x 160 cm  
31.49" x 62.99"



**60x120**  
59,55 x 119,3 cm  
23.45" x 46.97"



**60x60**  
59,55 x 59,55 cm  
23.45" x 23.45"



**60x60**  
59,55 x 59,55 cm  
23.45" x 23.45"

# Ocean Blue Polished



Floor and Walls 6 mm	
Ocean Blue Polished 160x320	G-3495
Ocean Blue Polished 160x160	G-3495
Ocean Blue Polished 80x160	G-3495
Floor and Walls 7 mm	
Ocean Blue Polished 60x120	G-1442
Ocean Blue Polished 60x60	G-1298









Ocean Blue  
Decor  
Polished



Floor And Walls 7 mm

Ocean Blue Decor Polished 60x60

G-1314

Decor 7 mm

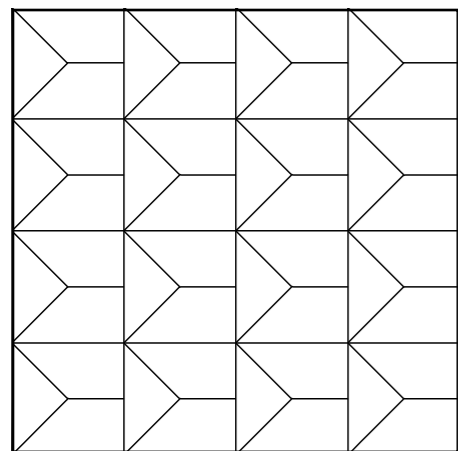

60x60  
59,55 x 59,55 cm  
23,45" x 23,45"



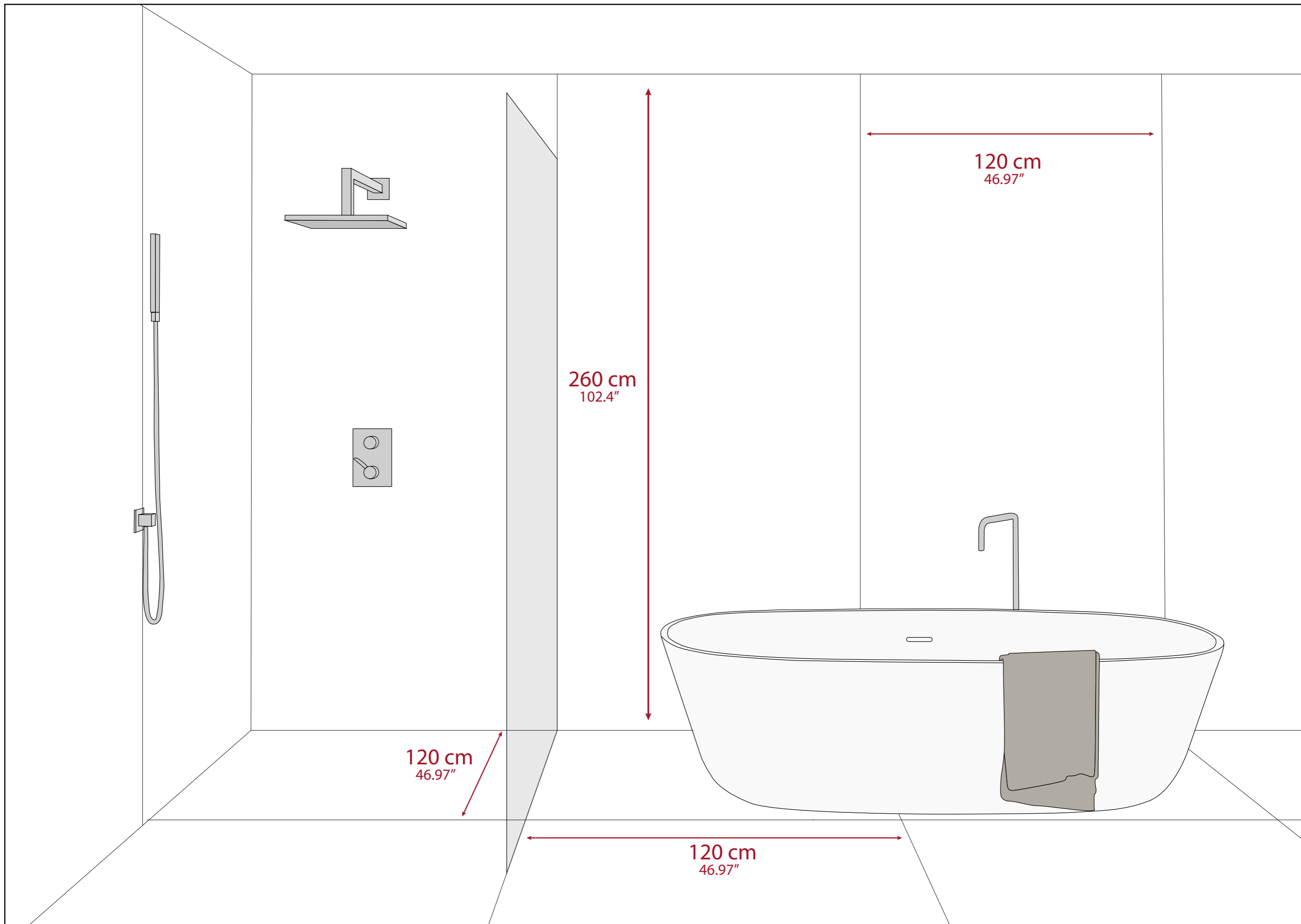

# Wild Forest

**Floor & Walls**  
Natural & Polished 6 mm

Polished 7 mm

Decor 7 mm



**120x260**  
119,3 x 260,0 cm  
46.97" x 102.4"



**60x260**  
59,55 x 260,0 cm  
23.45" x 102.4"



**120x120**  
119,3 x 119,3 cm  
46.97" x 46.97"



**60x120**  
59,55 x 119,3 cm  
23.45" x 46.97"



**60x60**  
59,55 x 59,55 cm  
23.45" x 23.45"



**60x60**  
59,55 x 59,55 cm  
23.45" x 23.45"

Wild Forest

Wild Forest  
Natural

Wild Forest  
Polished

# Wild Forest Grey Polished A + B + C



Floor and Walls 6 mm  
Wild Forest Grey Polished A + B + C 120x260 G-3495





**Block A**



**Block B**



**Block C**

# Wild Forest Grey Polished Mix / Natural Mix



---

## Floor And Walls 6 mm

Wild Forest Grey Polished Mix 120X260 G-3459

Wild Forest Grey Natural Mix 120X260 G-3397

Wild Forest Grey Polished Mix 60X260 G-3459

Wild Forest Grey Natural Mix 60X260 G-3397

Wild Forest Grey Polished Mix 120X120 G-3459

Wild Forest Grey Natural Mix 120X120 G-3397

---

## Floor And Walls 7 mm

Wild Forest Grey Polished 60X120 G-1442

Wild Forest Grey Polished 60X60 G-1298











# Wild Forest Decor Polished

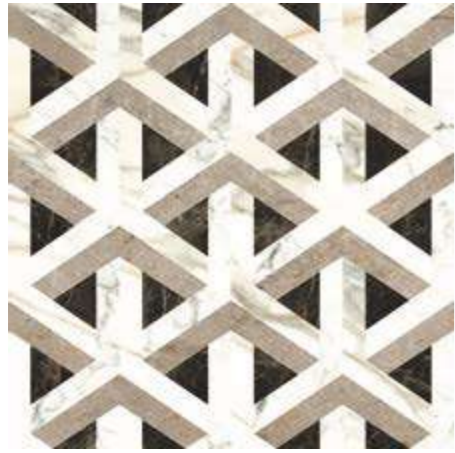

Floor And Walls 7 mm

Wild Forest Decor Polished 60x60

G-1314

Decor 7 mm

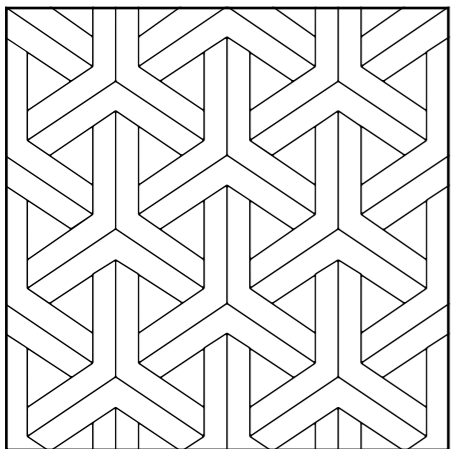

**60x60**  
59,55 x 59,55 cm  
23,45" x 23,45"

Verify placement of the piece in your installation. The relief has position.  
Verificar colocación de la pieza en su instalación. El relieve tiene posición.



# Borghini

Borghini  
Polished

# Borghini

**Floor & Walls**  
Polished 6 mm

---

Polished 7 mm

Decor 7 mm



**120x260**  
119,3 x 260,0 cm  
46.97" x 102.4"



**60x260**  
59,55 x 260,0 cm  
23.45" x 102.4"



**120x120**  
119,3 x 119,3 cm  
46.97" x 46.97"



**60x120**  
59,55 x 119,3 cm  
23.45" x 46.97"



**60x60**  
59,55 x 59,55 cm  
23.45" x 23.45"

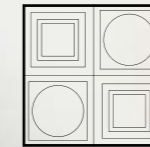

**60x60**  
59,55 x 59,55 cm  
23.45" x 23.45"

# Borghini White



---

Floor and Walls 6 mm

Borghini White Polished 120X260 G-3467

Borghini White Polished 60X260 G-3467

Borghini White Polished 120X120 G-3467

---

Floor and Walls 7 mm

Borghini White Polished 60X120 G-1442

Borghini White Polished 60X60 G-1298









# Borghini White Decor Polished



Floor And Walls 7 mm

Borghini White Decor Polished 60x60 G-1314

Decor 7 mm

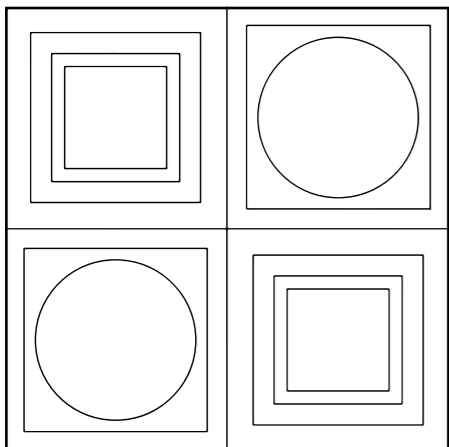

**60x60**  
59,55 x 59,55 cm  
23,45" x 23,45"



# Elegance

**Floor & Walls**  
Polished 6 mm

---



**120x260**  
119,3 x 260,0 cm  
46.97" x 102.4"

Elegance  
White  
Polished

# Elegance

# Elegance White Polished

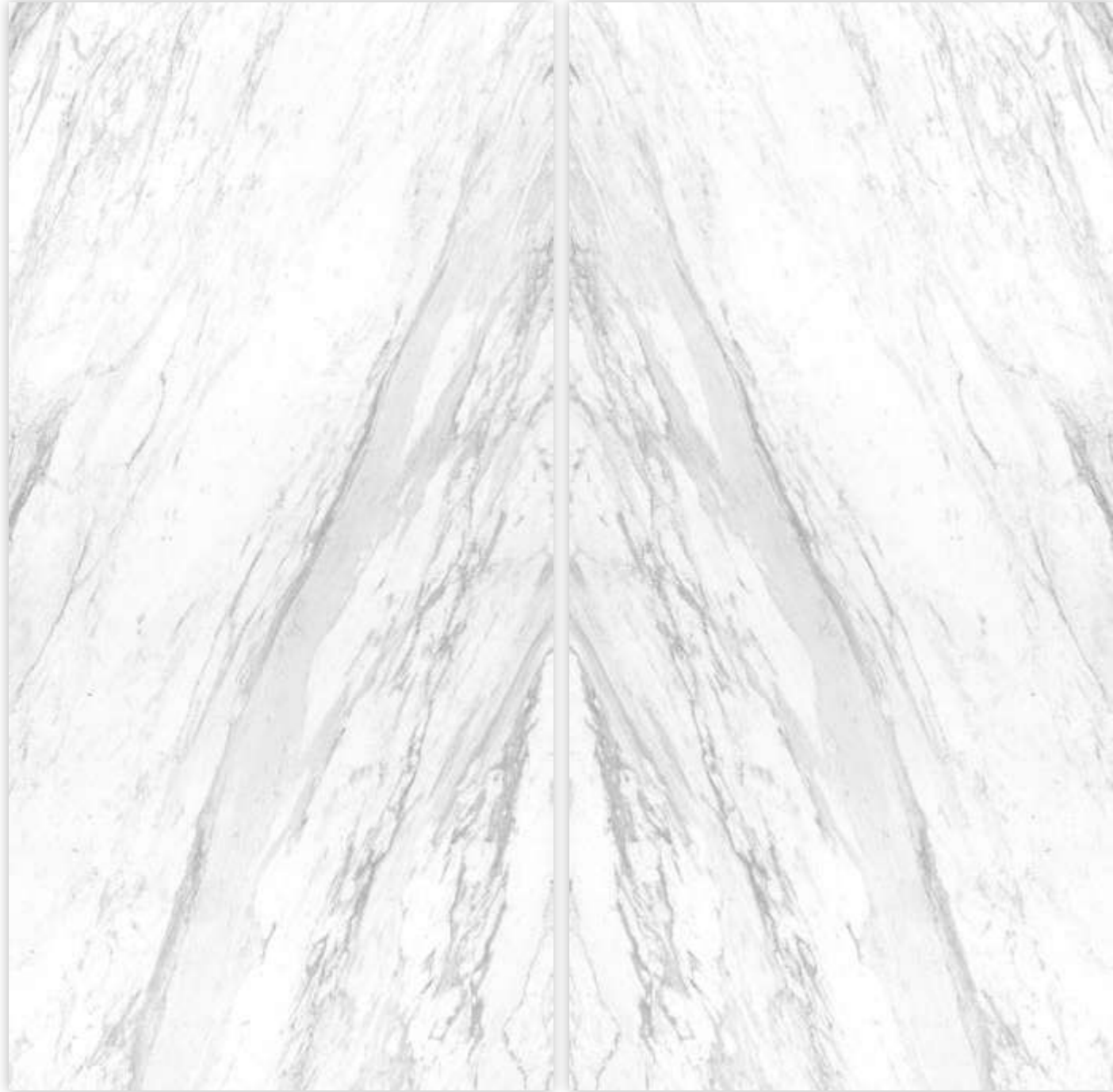

Block A

Block B



Floor and Walls 6 mm	
Elegance White Polished BL.A 120x260*	G-3495
Elegance White Polished BL.B 120x260*	G-3495

Bookmatch

\*Elegance White Polished Bookmatch 120x260 block A & block B not sold separately / Los bloques A y B 120x260 de Elegance White Polished Bookmatch no se venden por separado.

Block B

Block A

Block A

Block B

Block B

Block A

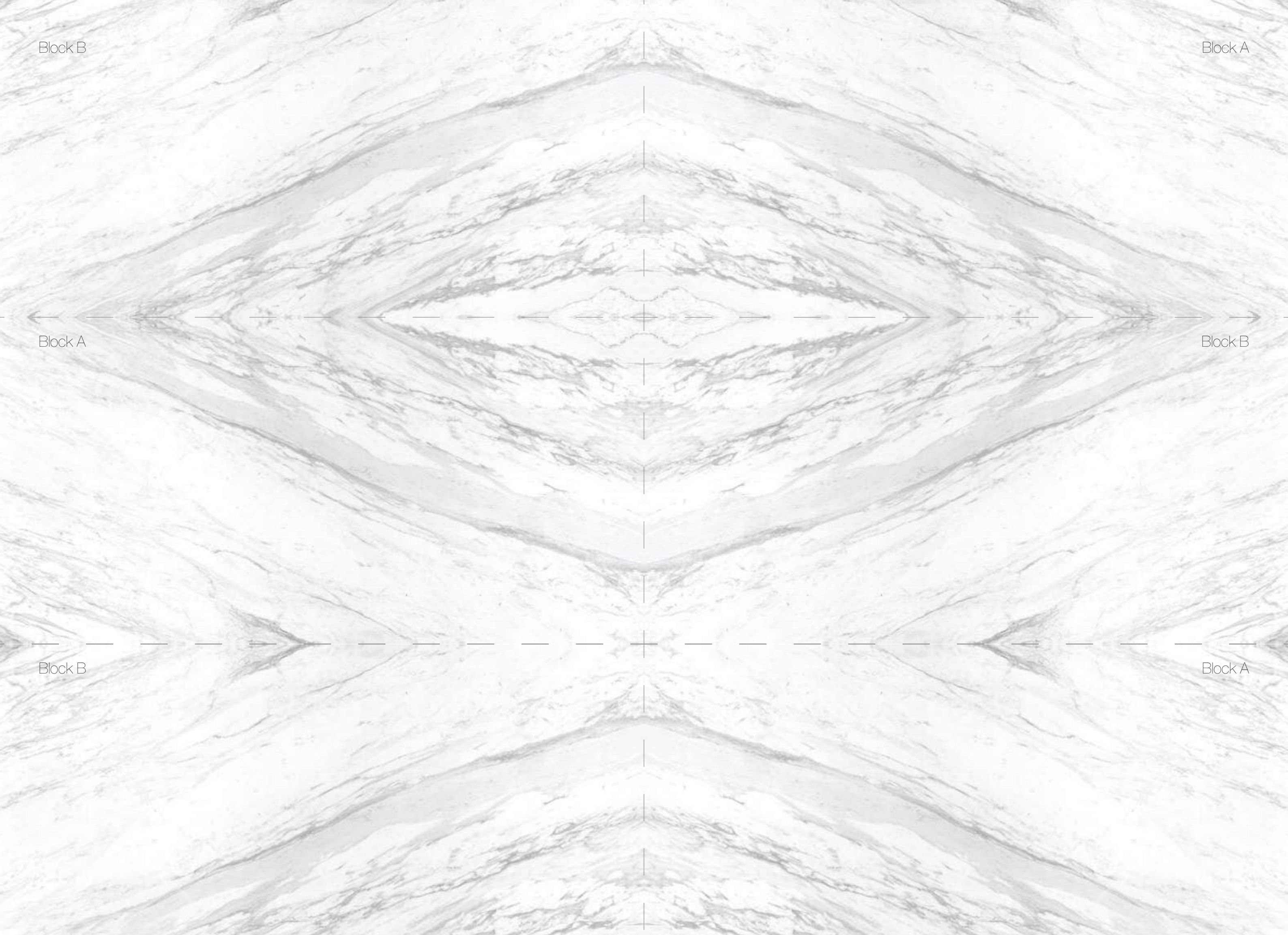



Block A

Block A



# Statuario

**Linetops**  
Natural & Polished 12mm

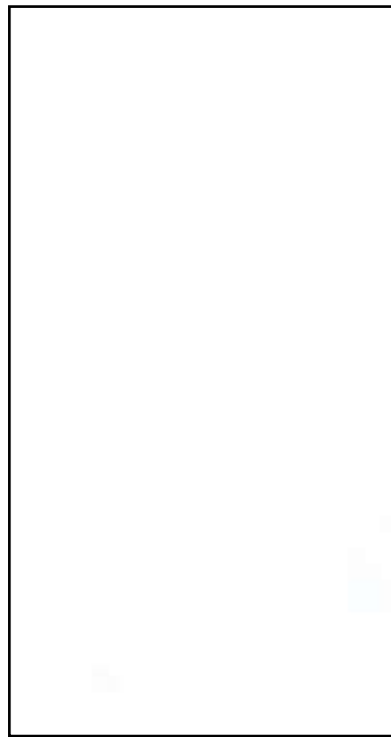

**162x324**  
162 x 324 cm  
63.8" x 127.6"

**Floor & Walls**  
Natural & Polished 6,5mm



**120x260**  
119,3 x 260,0 cm  
46.97" x 102.4"

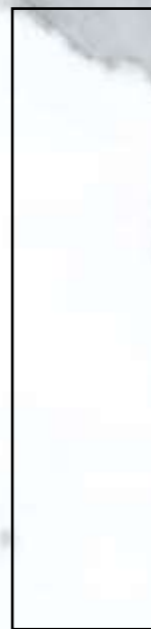

**60x260**  
59,55 x 260,0 cm  
23.45" x 102.4"



**120x120**  
119,3 x 119,3 cm  
46.97" x 46.97"

# Statuario

Statuario  
Extra  
White  
Natural

Statuario  
Extra  
White  
Polished

# Statuario Extra White Polished



Block A

Block B

Linetops 12 mm	
Statuario Extra White Polished BL.A 162x324*	G-3753
Statuario Extra White Polished BL.B 162x324*	G-3753
Floor and Walls 6 mm	
Statuario Extra White Polished BL.A 120x260*	G-3495
Statuario Extra White Polished BL.B 120x260*	G-3495

Bookmatch



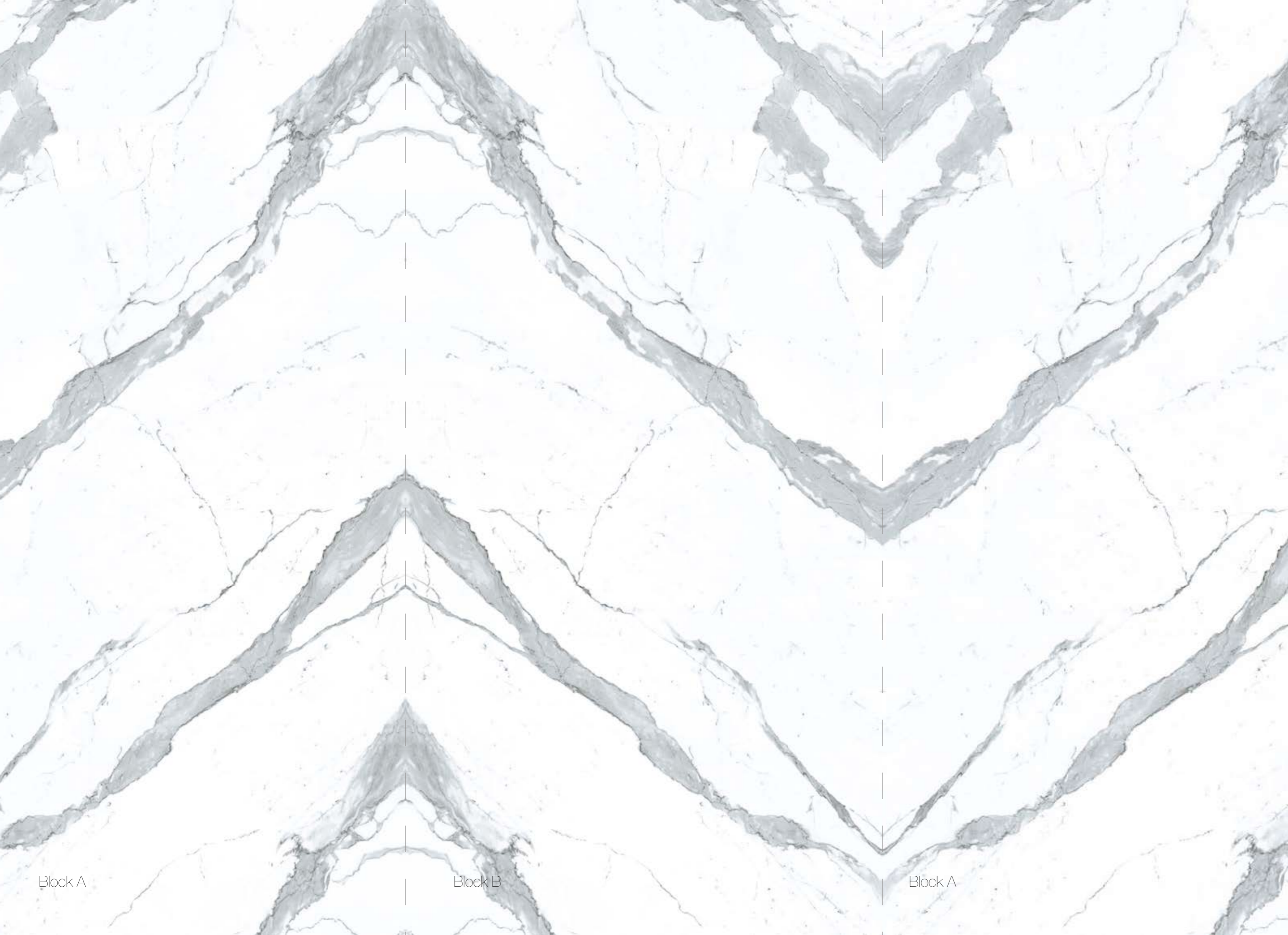

Block A

Block B

Block A





# Slabs 12.0

Linelop



# Statuario Extra White Polished Mix / Natural Mix



Floor and Walls 6 mm

Statuario Extra White Polished Mix 120x260 G-3467

Statuario Extra White Natural Mix 120x260 G-3413

Statuario Extra White Polished Mix 60x260 G-3467

Statuario Extra White Natural Mix 60x260 G-3413

Statuario Extra White Polished Mix 120x120 G-3467

Statuario Extra White Natural Mix 120x120 G-3413





# Statuario White Polished Prism Decor

**Walls**  
6 mm



**60x260**  
59,55 x 260,0 cm  
23,45" x 102,4"

Statuario White Polished Prism Decor 60X260 G-2930



# Statuario White Polished Leaves Decor

**Walls**  
6 mm



**60x260**  
59,55 x 260,0 cm  
23,45" x 102,4"

Statuario White Polished Leaves Decor 60X260 G-2930





# Statuario White Polished Diamond Decor

**Walls**  
6 mm

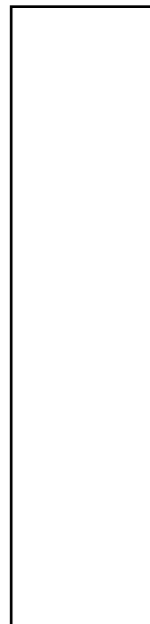

**60x260**  
59,55 x 260,0 cm  
23,45" x 102,4"

Statuario White Polished Diamond Decor 60X260 G-2930



# Tattoo

Tattoo  
Oxidum  
decor

Tattoo  
White  
Natural  
&  
Satin

Tattoo  
Black  
decor

# Tattoo

**Linetops**  
Decor 12mm

**Floor & Walls**  
Decor & Natural 6,5mm

Decor & Satin 7,4mm

**Non-slip** **Outdoor**  
7,4mm 20mm



**162x324**  
162 x 324 cm  
63.8" x 127.6"



**120x260**  
119,3 x 260,0 cm  
46.97" x 102.4"

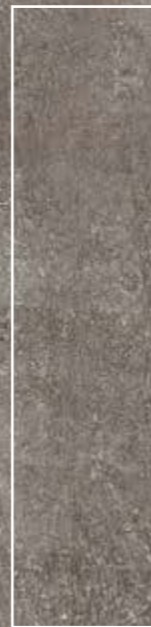

**60x260**  
59,55 x 260,0 cm  
23.45" x 102.4"



**120x120**  
119,3 x 119,3 cm  
46.97" x 46.97"



**90x90**  
89,46 x 89,46 cm  
35.22" x 35.22"



**45x90**  
44,63 x 89,46 cm  
17.57" x 35.22"



**30x60**  
29,75 x 59,55 cm  
11.71" x 23.45"

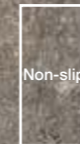

**30x30**  
29,75 x 29,75 cm  
11.71" x 11.71"

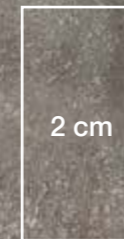

**50x100**  
49,75 x 99,55 cm  
19.59" x 39.19"

2 cm

Non-slip

# Tattoo Oxidum Decor



---

## Linetops 12 mm

Tattoo Oxidum Decor Linetops 162x324	G-3653
--------------------------------------	--------

---

## Floor and Walls 6 mm

Tattoo Oxidum Decor 120x260	G-3413
-----------------------------	--------

Tattoo Oxidum Decor 60x260	G-3413
----------------------------	--------

Tattoo Oxidum Decor 120x120	G-3413
-----------------------------	--------

---

## Floor and Walls 7 mm

Tattoo Oxidum Decor 90x90	G-1372
---------------------------	--------

Tattoo Oxidum Decor 45x90	G-1250
---------------------------	--------

Tattoo Oxidum Decor 30x60	G-1202
---------------------------	--------

---

## Decor Walls 6 mm

Tattoo Oxidum Graffiti Decor 60x260	G-2928
-------------------------------------	--------







# Tattoo Black Decor



Floor and Walls 6 mm

Tattoo Black Decor 120x260 G-3413

Tattoo Black Decor 60x260 G-3413

Tattoo Black Decor 120x120 G-3413

Floor and Walls 7 mm

Tattoo Black Decor 90x90 G-1372

Tattoo Black Decor 45x90 G-1250

Tattoo Black Decor 30x60 G-1202

Non-Slip 7 mm

Tattoo Black Non-Slip 30x60 G-1232

Solid 2 CM 20 mm

Tattoo Black Solid 2 CM 50x100 G-1258









# Tattoo White Natural / White Satin



<hr/>	
Floor and Walls 6 mm	
Tattoo White Natural 120x260	G-3365
Tattoo White Natural 60x260	G-3365
Tattoo White Natural 120x120	G-3365
<hr/>	
Floor and Walls 7 mm	
Tattoo White Satin 90x90	G-1372
Tattoo White Satin 45x90	G-1250
Tattoo White Satin 30x60	G-1202
<hr/>	
Non-Slip 7 mm	
Tattoo White Non-Slip 30x60	G-1232

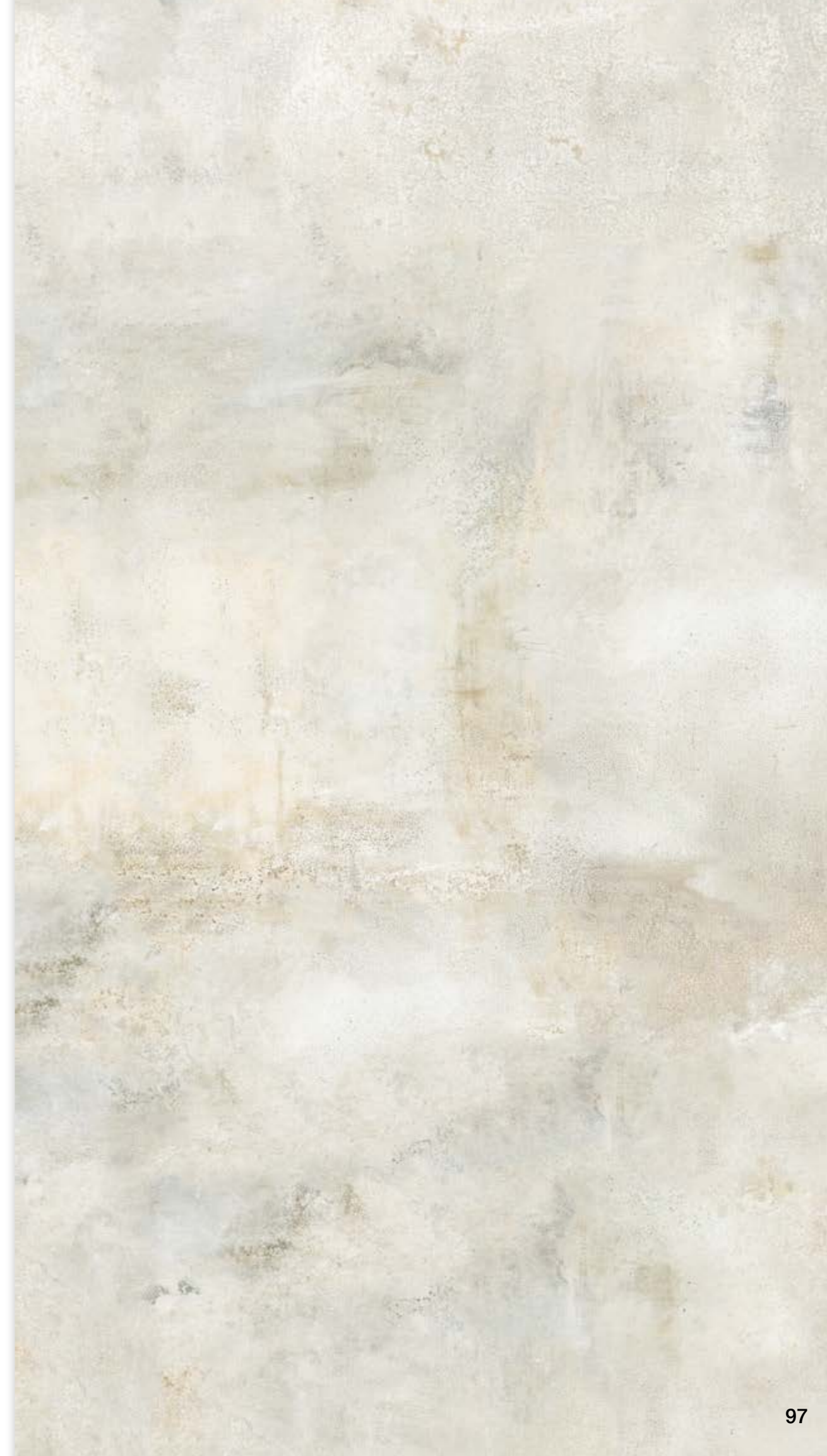





# Tattoo Oxidum Graffiti Decor

**Walls**  
6,5mm

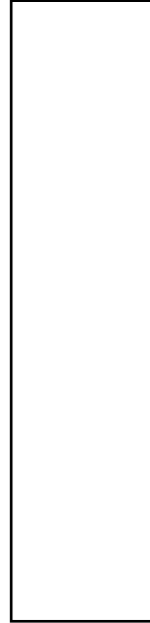

**60x260**  
59,55 x 260,0 cm  
23,45" x 102,4"

Tattoo Oxidum Graffiti Decor 60X260 G-2928



# Instinto

Instinto  
Taupe

Instinto  
White

# Instinto

**Floor & Walls**  
Natural 6 mm

**Floor & Walls**  
Natural / Lapato 7 mm

**Walls**  
Rescato 7 mm

**Outdoor**  
20 mm

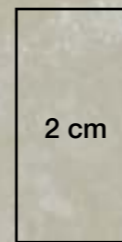

**120x260**  
119,3 x 260,0 cm  
46.97" x 102.4"

**60x260**  
59,55 x 260,0 cm  
23.45" x 102.4"

**120x120**  
119,3 x 119,3 cm  
46.97" x 46.97"

**90x90**  
89,46 x 89,46 cm  
35.22" x 35.22"

**45x90**  
44,63 x 89,46 cm  
17.57" x 35.22"

**45x90**  
44,63 x 89,46 cm  
17.57" x 35.22"

**50x100**  
49,75 x 99,55 cm  
19.59" x 39.19"

# Instinto Taupe

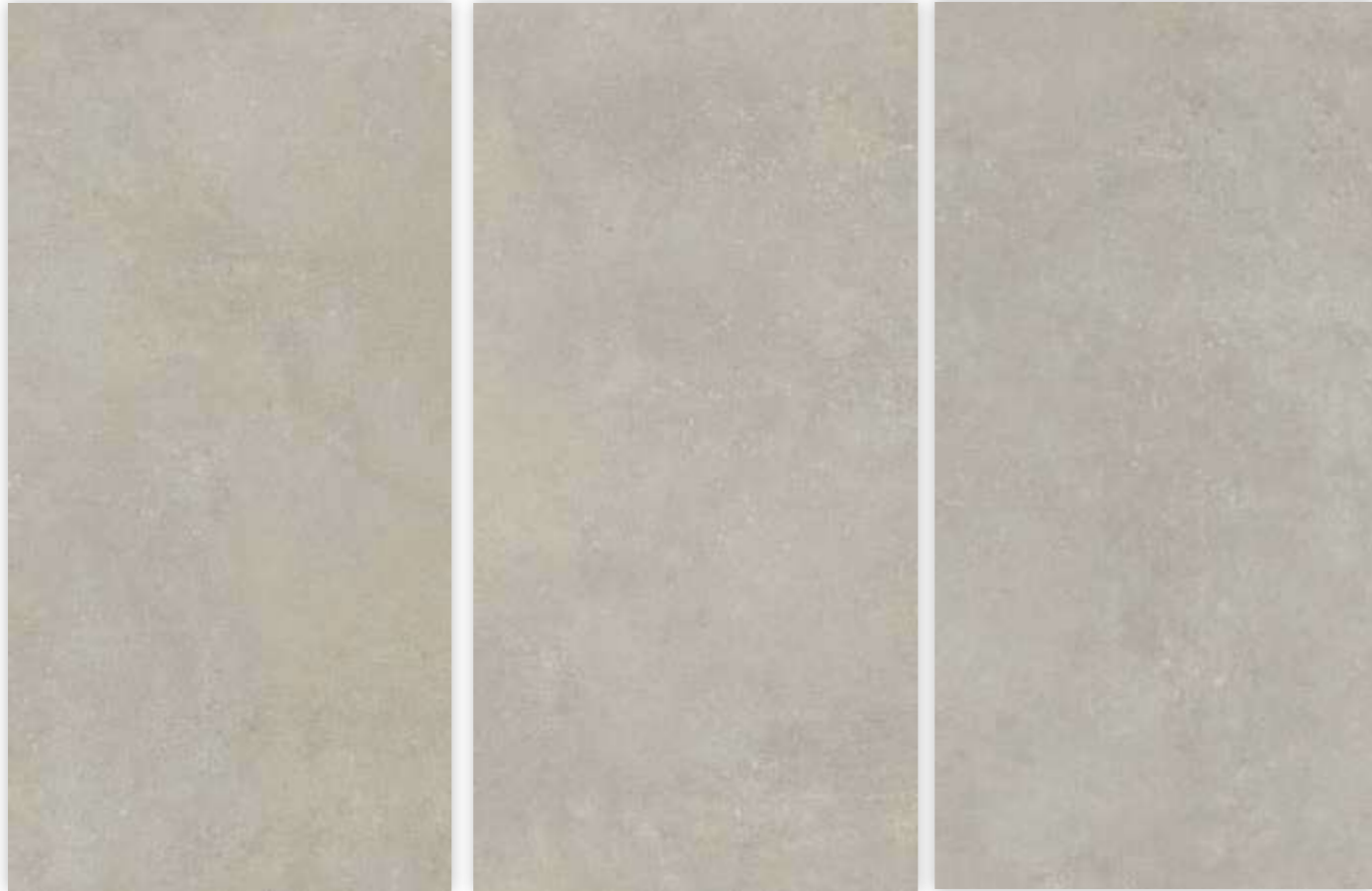

<hr/>	
Floor and Walls 6 mm	
Instinto Taupe Natural 120X260	G-3365
Instinto Taupe Natural 60X260	G-3365
Instinto Taupe Natural 120X120	G-3365
<hr/>	
Floor and Walls 7 mm	
Instinto Taupe Natural 90X90	G-1298
Instinto Taupe Lappato 90X90	G-1330
Instinto Taupe Natural 45X90	G-1202
Instinto Taupe Lappato 45X90	G-1234
Instinto Taupe Rescato 45X90	G-1234
<hr/>	
Floor Solid 2 cm	
Instinto Taupe Solid 2 cm 50X100	G-1258





# Instinto Taupe Rescato



Walls 7 mm

Instinto Taupe Rescato 45X90

G-1234

FINISH

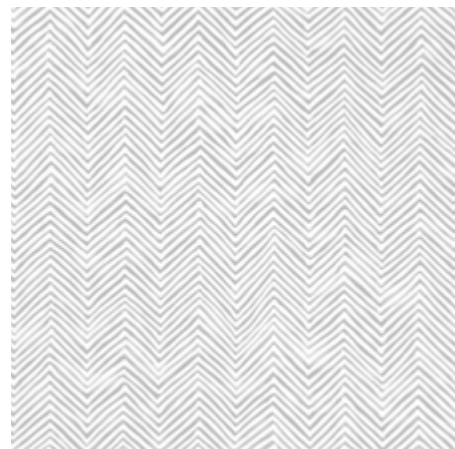

Verify placement of the piece in your installation. The relief has position.  
Verificar colocación de la pieza en su instalación. El relieve tiene posición.







# Instinto Natural Mosaico Brick



Instinto Taupe Natural Mosaico Brick G-1942



Instinto White Natural Mosaico Brick G-1942

## Mosaico Brick 7 mm

0	+5	0	+5	0	+5	0	+5
+5	0	+5	0	+5	0	+5	0
0	+5	0	+5	0	+5	0	+5
+5	0	+5	0	+5	0	+5	0

**30x30**  
29,75 x 29,75 cm  
11,71" x 11,71"





# Instinto White



Floor and Walls 6 mm

Instinto White Natural 120X260	G-3365
Instinto White Natural 60X260	G-3365
Instinto White Natural 120X120	G-3365

Floor and Walls 7 mm

Instinto White Natural 90X90	G-1298
Instinto White Lappato 90X90	G-1330
Instinto White Natural 45X90	G-1202
Instinto White Lappato 45X90	G-1234
Instinto White Rescato 45X90	G-1234



# Instinto Lappato Flake



Instinto White Lappato Flake

G-1708



Instinto Taupe Lappato Flake

G-1708

Mosaico Flake 7 mm

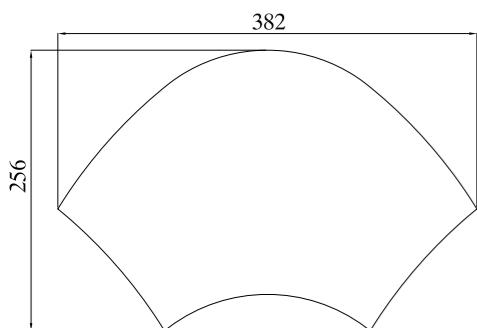

**25x25**  
25,09 x 25,09 cm  
9,87" x 9,87"







# Instinto White Rescato



Walls 7 mm

Instinto White Rescato 45X90

G-1234

FINISH

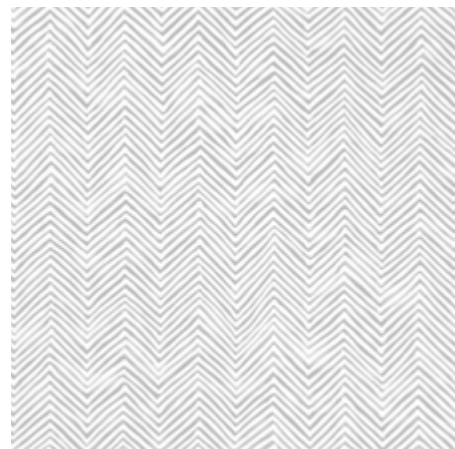

Verify placement of the piece in your installation. The relief has position.  
Verificar colocación de la pieza en su instalación. El relieve tiene posición.





# Equinox

Equinox  
Grey  
Natural

Equinox  
White  
Natural

Equinox  
Anthracite  
Natural

# Equinox

**Linetops**  
Natural 12 mm

**Floor & Walls**  
Natural 6 mm

Satin 7 mm

**Non-slip** **Outdoor**  
7 mm 20 mm



**162x324**  
162 x 324 cm  
63.8" x 127.6"



**120x260**  
119,3 x 260,0 cm  
46.97" x 102.4"

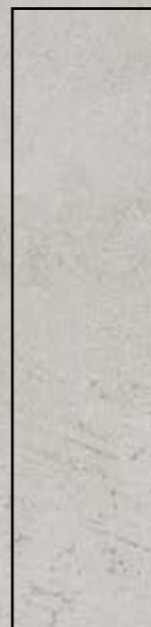

**60x260**  
59,55 x 260,0 cm  
23.45" x 102.4"



**120x120**  
119,3 x 119,3 cm  
46.97" x 46.97"



**60x120**  
59,55 x 119,3 cm  
23.45" x 46.97"



**60x60**  
59,55 x 59,55 cm  
23.45" x 23.45"

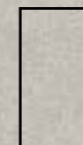

**30x60**  
29,75 x 59,55 cm  
11.71" x 23.45"

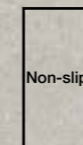

**30x60**  
29,75 x 59,55 cm  
11.71" x 23.45"

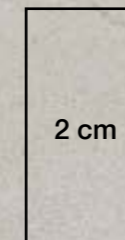

**50x100**  
49,75 x 99,55 cm  
19.59" x 39.19"

2 cm

Non-slip

# Equinox White Natural / White Satin



Floor and Walls 6 mm		
Equinox White Natural	120x260	G-3381
Equinox White Natural	60x260	G-3381
Equinox White Natural	120x120	G-3381
Floor and Walls 7 mm		
Equinox White Satin	60x120	G-1282
Equinox White Satin	60x60	G-1180
Equinox White Satin	30x60	G-1162





# Equinox Grey Natural / Grey Satin

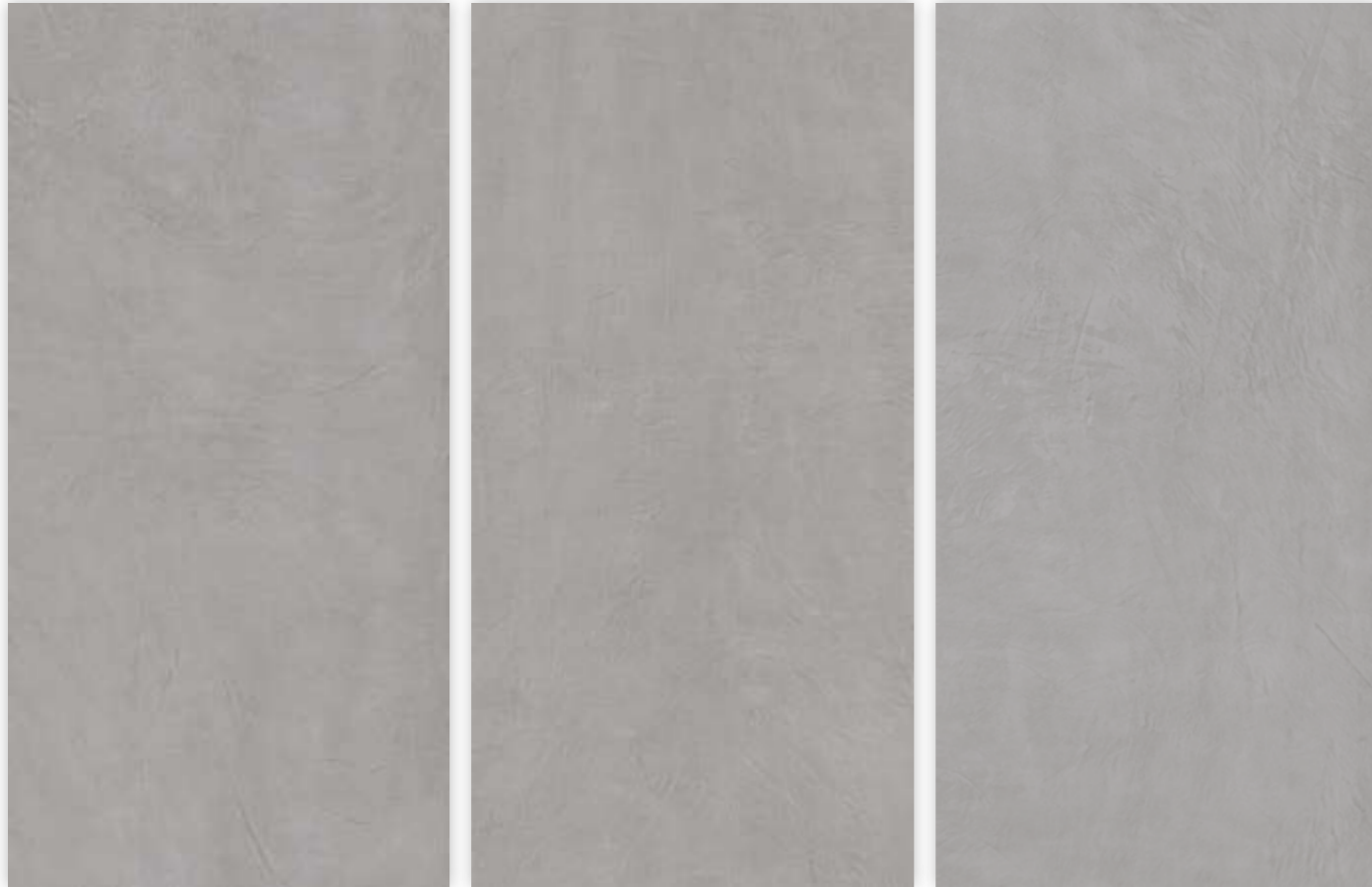

Linetops 12 mm		
Equinox Grey Natural Linetops 162x324		G-3647
Floor and Walls 6 mm		
Equinox Grey Natural 120x260		G-3381
Equinox Grey Natural 60x260		G-3381
Equinox Grey Natural 120x120		G-3381
Floor and Walls 7 mm		
Equinox Grey Satin 60x120		G-1282
Equinox Grey Satin 60x60		G-1180
Equinox Grey Satin 30x60		G-1162
Non-Slip 7 mm		
Equinox Grey Non-Slip 30x60		G-1194
Solid 2 CM 20 mm		
Equinox Grey Solid 2 CM 50x100		G-1258







slabs 12.0  
LineTop



# Equinox Anthracite Natural / Anthracite Satin



<hr/>	
Floor and Walls 6 mm	
Equinox Anthracite Natural 120x260	G-3381
Equinox Anthracite Natural 60x260	G-3381
Equinox Anthracite Natural 120x120	G-3381
<hr/>	
Floor and Walls 7 mm	
Equinox Anthracite Satin 60x120	G-1298
Equinox Anthracite Satin 60x60	G-1202
Equinox Anthracite Satin 30x60	G-1180
<hr/>	
Non-Slip 7 mm	
Equinox Anthracite Non-Slip 30x60	G-1208
<hr/>	
Decor Walls 6mm	
Equinox Anthracite Diamond Decor 60x260	G-2928







# Equinox Anthracite Diamond Decor

**Walls**  
6,5mm



**60x260**  
59,55 x 260,0 cm  
23.45" x 102.4"

Equinox Anthracite Diamond Decor 60X260

G-2928



# Pietra grey

**Linetops**  
Natural & Polished 12mm

**Floor & Walls**  
Natural & Polished 6,5mm



**162x324**  
162 x 324 cm  
63.8" x 127.6"



**120x260**  
119,3 x 260,0 cm  
46.97" x 102.4"



**60x260**  
59,55 x 260,0 cm  
23.45" x 102.4"



**120x120**  
119,3 x 119,3 cm  
46.97" x 46.97"

Pietra Grey

Pietra  
Grey  
Natural

Pietra  
Grey  
Polished

# Pietra Grey Polished / Natural



---

## Linetops 12 mm

Pietra Grey Polished 162x324 G-3717

Pietra Grey Natural 162x324 G-3663

---

## Floor and Walls 6 mm

Pietra Grey Polished 120x260 G-3459

Pietra Grey Natural 120x260 G-3397

Pietra Grey Polished 60x260 G-3459

Pietra Grey Natural 60x260 G-3397

Pietra Grey Polished 120x120 G-3459

Pietra Grey Natural 120x120 G-3397

---

## Walls Decor 6 mm

Pietra Grey Polished Leaves Decor 60x260 G-2930









slabs 12.0  
LineTop





# Pietra Grey Polished Leaves Decor

**Walls**  
6,5mm

---



**60x260**  
59,55 x 260,0 cm  
23.45" x 102.4"

Pietra Grey Polished Leaves Decor 60X260

G-2930



# St. Vincent

St. Vincent  
Anthracite  
Natural

St. Vincent  
Anthracite  
Polished

## St. Vincent

**Linetops**  
Natural & Polished 12mm

**Floor & Walls**  
Natural & Polished 6 mm

**Outdoor**  
20 mm

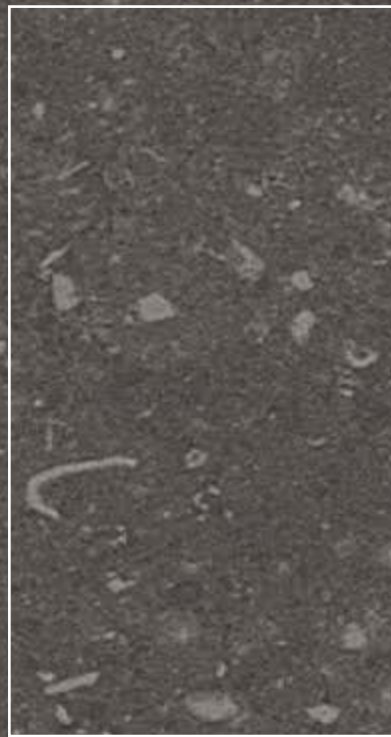

**162x324**  
162 x 324 cm  
63.8" x 127.6"

G-4630

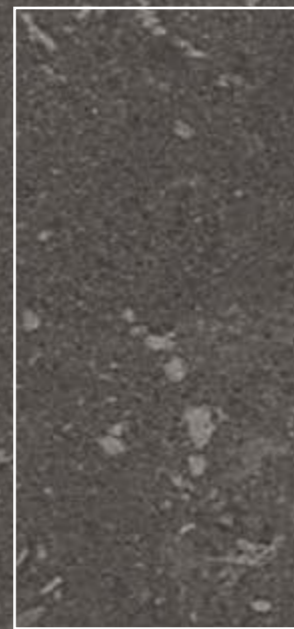

**120x260**  
119,3 x 260,0 cm  
46.97" x 102.4"

G-4583

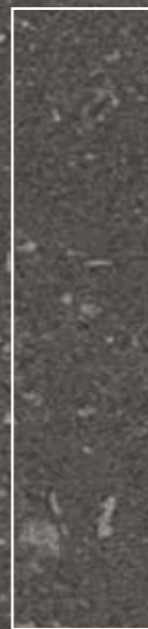

**60x260**  
59,55 x 260,0 cm  
23.45" x 102.4"

G-4583

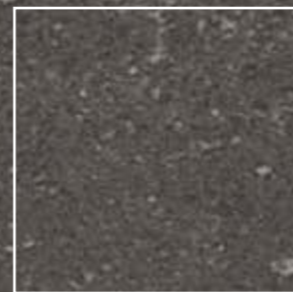

**120x120**  
119,3 x 119,3 cm  
46.97" x 46.97"

G-4583

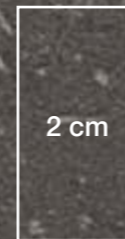

**50x100**  
49,75 x 99,55 cm  
19.59" x 39.19"

G-4583

2 cm

# St. Vincent Anthracite Polished / Anthracite Natural



## Linetops 12 mm

St. Vincent Anthracite Polished 162x324 G-3717

St. Vincent Anthracite Natural 162x324 G-3663

## Floor and Walls 6 mm

St. Vincent Anthracite Polished 120x260 G-3451

St. Vincent Anthracite Natural 120x260 G-3381

St. Vincent Anthracite Polished 60x260 G-3451

St. Vincent Anthracite Natural 60x260 G-3381

St. Vincent Anthracite Polished 120x120 G-3451

St. Vincent Anthracite Natural 120x120 G-3381

## Solid 2 CM 20 mm

St. Vincent Anthracite Solid 2 CM 50x100 G-1258







slabs 12.0  
LineTop



slabs 12.0  
LineTop







# Junoon

**Floor & Walls**  
Natural 6 mm

**Outdoor**  
20 mm



**120x260**  
119,3 x 260,0 cm  
46.97" x 102.4"



**60x260**  
59,55 x 260,0 cm  
23.45" x 102.4"

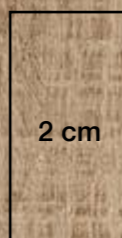

**50x100**  
49,75 x 99,55 cm  
19.59" x 39.19"

2 cm

# Junoon

Junoon  
Beige  
Natural

Junoon  
Maple  
Natural

Junoon  
Brown  
Natural

# Junoon Beige Natural



Floor and Walls 6 mm	
Junoon Beige Natural 120x260	G-3391
Junoon Beige Natural 30x260	G-3371
Solid 2 CM 20 mm	
Junoon Beige Solid 2 CM 50x100	G-1258







# Junoon Maple Natural



Floor and Walls 6 mm	
Junoon Maple Natural 120x260	G-3391
Junoon Maple Natural 30x260	G-3371
Solid 2 CM 20 mm	
Junoon Maple Solid 2 CM 50x100	G-1258







# Junoon Brown Natural



Floor and Walls 6 mm  
Junoon Brown Natural 120x260 G-3391  
Junoon Brown Natural 30x260 G-3371





# Calacatta Lincoln

**Linetops**  
Natural & Polished 12mm

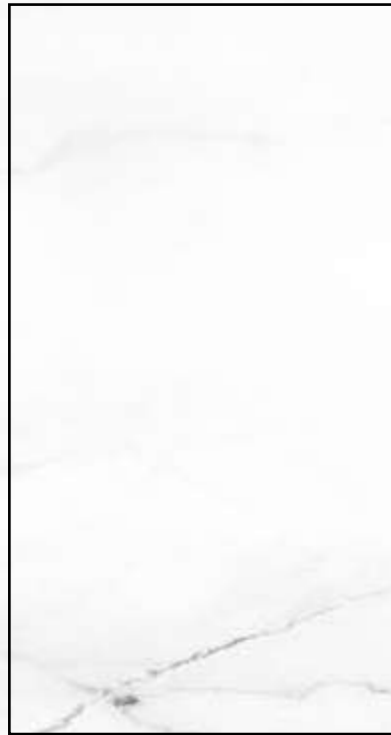

**162x324**  
162 x 324 cm  
63.8" x 127.6"

Calacatta Lincoln

Calacatta  
Lincoln  
Natural

Calacatta  
Lincoln  
Polished

slabos 12.0  
Linetop





# Super White

**Linetops**  
Natural & Polished 12mm

---

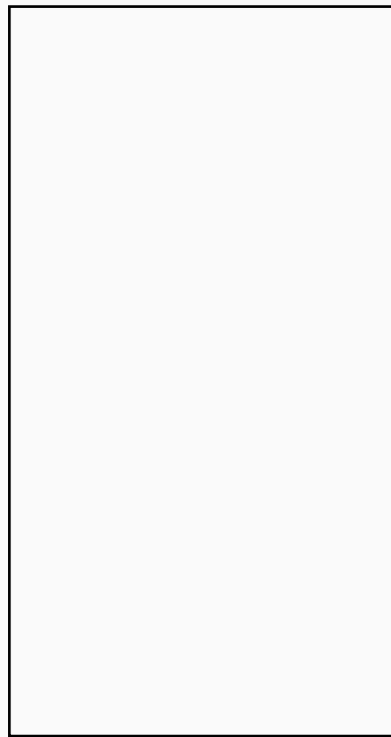

**162x324**  
162 x 324 cm  
63.8" x 127.6"

Super White

Super White  
Natural

Super White  
Polished

slabs 12.0  
LineTop



slabs 12.0  
Linetop



# Agata Blue

**Linetops**  
Natural & Polished 12mm



162x324  
162 x 324 cm  
63.8" x 127.6"

Agata Blue  
Polished

# Agata Blue



slabs 12.0  
LineTop



slabs<sup>12.0</sup>  
Linetop



# Technical information

## Technical information

Floor & wall installation	174
Pavimentado y alicatado	176
Cutting	178
Corte	180
Cleaning & maintenance	182
Limpieza y mantenimiento	183
Handling / Manipulación	184
Packing	186
Ventilated Facades	188
Specs / Características	189

# Floor & wall installation

## Surface preparation

If the fixing surface is smooth (self-levelling mortar bed), it needs to be pre-roughened before cleaning by sandpapering with extra-large grit to enhance bonding. The fixing surface shall be flat and cleaned of any dust or impurities by using an acid solvent (e.g. hydrochloric acid) as well as a base solvent (e.g. ammonia).

## Choosing the right adhesive

The tiles shall be installed in both interiors and exteriors using class C2 cementitious adhesives with highly flexible S2 type enhanced deformability according to standard EN12004. In exteriors subject to extreme heat or places exposed to harsh climate conditions, it is advisable to use adhesives with class E extended open time according to standard EN12004. For outdoor tile installations in very cold climates it is recommended to use type F fast-setting adhesives according to standard EN12004 to avoid freezing of the mixing water.

## Adhesive application

The adhesive shall be applied by buttering and floating with a notched trowel between 5 and 8mm. Buttering and floating involves applying the bonding material both to the back of the ceramic tile and to the fixing surface to assure full contact between the two adhered surfaces and the bonding material. The grooves made with the notched trowel must cross each other without ever displaying a preferential direction.

## Positioning

The pieces need to be raised and placed with a positioning frame by suction pads to avoid any stress build-up in the piece during handling. After positioning the piece, it is essential to tap its entire surface with a mallet or rubber trowel to keep any air pockets from forming in the adhesive.

## Leveling (1)

- 1- Slab
- 2- Mortar bed
- 3- Leveling system

It is imperative for a correct positioning the use of leveling systems for ensuring good adjustment between slabs. Use at least two wedges for every side for an optimum result.

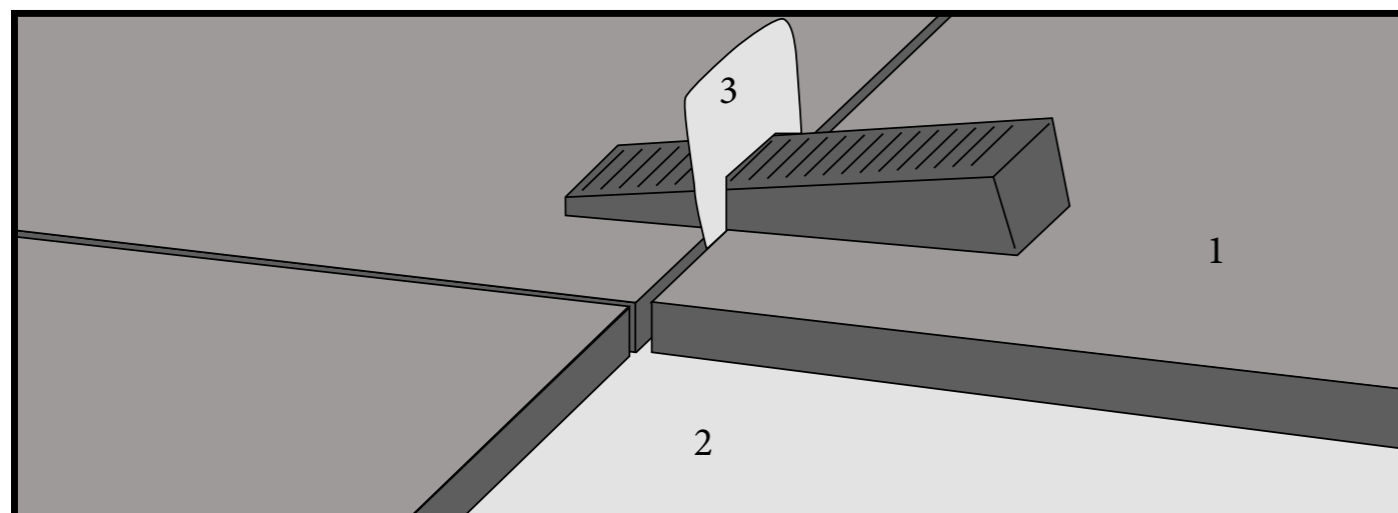

## Positioning system (2)

For an easy positioning is recommended the use of positioning systems as the one described (2). This kind of system offers good grip and security since it has vacuum cups to ensure slab stability and metal structure to avoid bending.

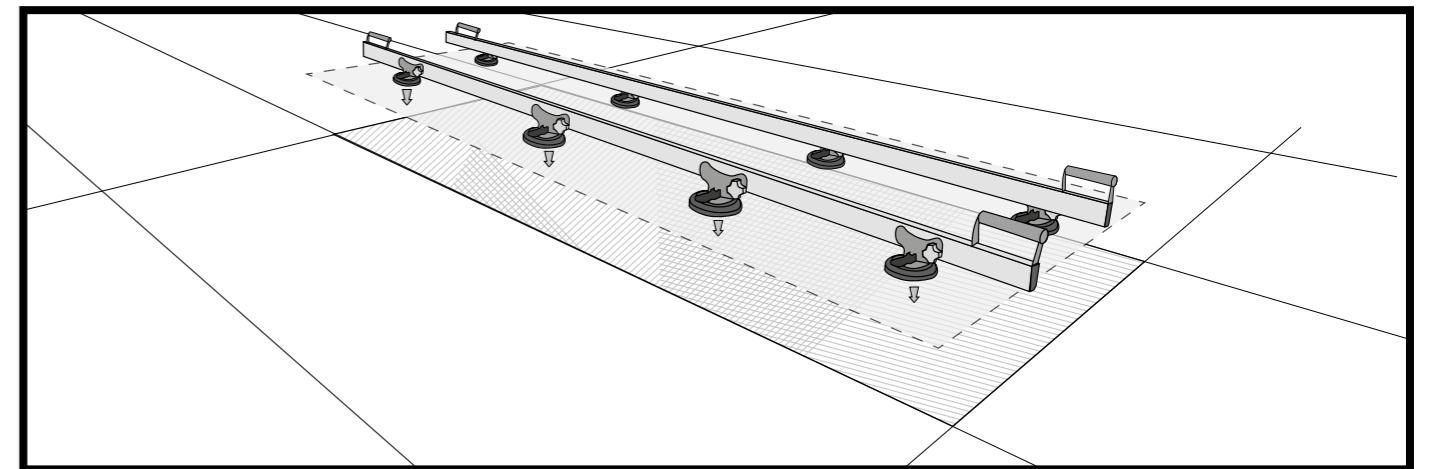

## Expansion joints (3)

During the positioning, joint spacers must be used to maintain a minimum joint of 2mm in interiors and of 5mm in exteriors. Never use a butt joint installation, as this entails cancellation of any applicable product guarantee. Maintaining the joint well assures appropriate adhesive strength during vibrations, taps, and temperature changes by allowing a certain leeway in dimensional and planimetric variations during appropriate use of the material.

## Movement joints (3)

Flexible movement joints shall be installed at each end of the installation, leaving a sufficient margin for movement between the structural elements and the tiles. These joints shall be at least 10mm wide and are to be observed both at the ends and at each 8–14 square metres of tile, depending on traffic and climate. In addition, structural joints shall always be respected to avoid any complementary shift between the material and the building's structural elements, as this drastically adversely affects material bonding to the substrate.

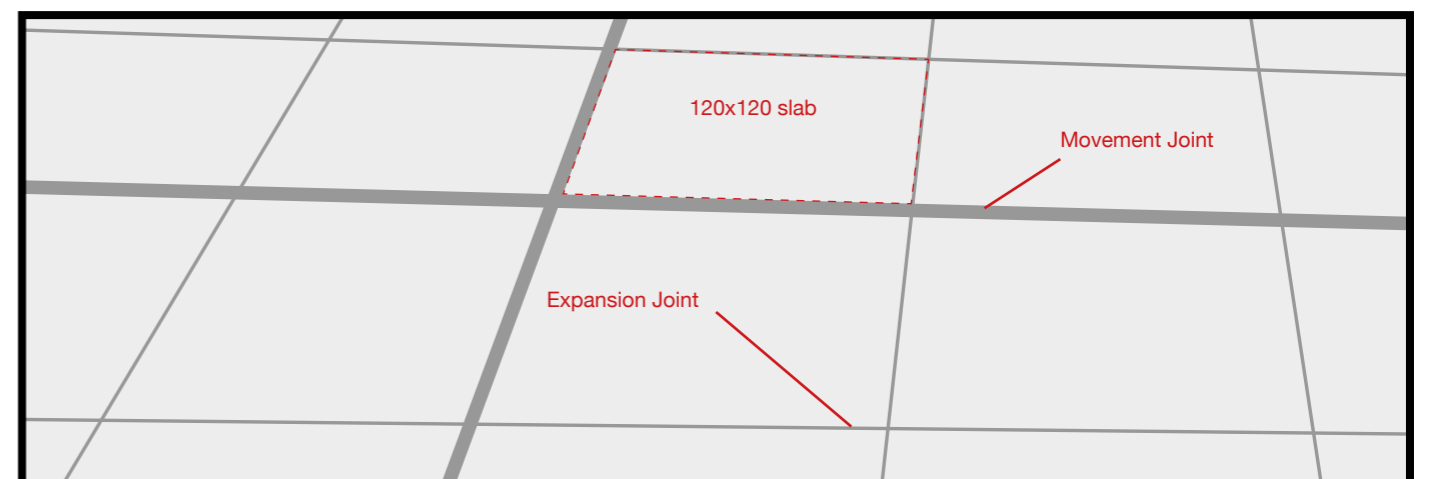

## Grouting and cleaning

It is recommended to use class CG2 cementitious grouting material according to EN13888 with water resistant and antimould properties. The grouting material shall be applied after proper setting of the adhesive and previous cleaning any overflowing adhesive material. Grouting shall be followed by thorough surface cleaning with a non-oil-based neutral pH detergent and subsequent absorption of the excess surplus water.

# Pavimentado y alicatado

## Preparación de la superficie de colocación

Si la superficie es lisa (lecho de cemento pulido) tiene que prepararse, previo a su limpieza, mediante lijado con papel de grano extragrande para mejorar su adherencia.

La superficie sobre la que se sitúe debe ser plana y limpiada de polvo e impurezas utilizando tanto un disolvente ácido (Ej. sulfamán) como básico (Ej. amoníaco).

## Elección del adhesivo correcto

Para colocación tanto en interiores como en exteriores se deben utilizar adhesivos cementosos clase C2 con mejora en deformabilidad tipo S2 "altamente flexible" de acuerdo a la norma EN12004.

En casos exteriores de extremo calor o en lugares con condiciones climáticas duras, es recomendable utilizar adhesivos con tiempo abierto ampliado de clase E según la norma EN12004.

Para colocaciones exteriores en climas muy fríos se recomienda el uso de adhesivos de fraguado rápido tipo F según la norma EN12004 para evitar la congelación del agua de mezcla.

## Aplicación del adhesivo

El adhesivo debe ser aplicado mediante doble encolado con una llana dentada de entre 5 y 8mm. El doble encolado consiste en la utilización de material adherente tanto en la parte posterior del material cerámico como en la superficie de posicionamiento con el fin de garantizar el contacto total entre los adheridos y el adherente.

Los surcos formados con la llana dentada deben entrecruzarse entre ellos sin mantener en ningún momento una direccionalidad preferente.

## Posicionamiento

Las piezas deben ser levantadas y situadas con un carro de posicionamiento por ventosas para evitar la acumulación de tensiones en la pieza durante su manipulación.

Una vez posicionada la pieza es imperativo dar golpes con un mazo o llana de goma a lo largo de toda la superficie para evitar la formación de bolsas de aire en el adhesivo.

## Nivelación (1)

- 1- Slab
- 2- Lecho de mortero
- 3- Sistema de nivelación

Es imperativo para un correcto posicionamiento el uso de sistemas de nivelación para asegurar el buen ajuste entre slabs. Es necesario utilizar al menos dos cuñas por cada lado para un resultado óptimo.

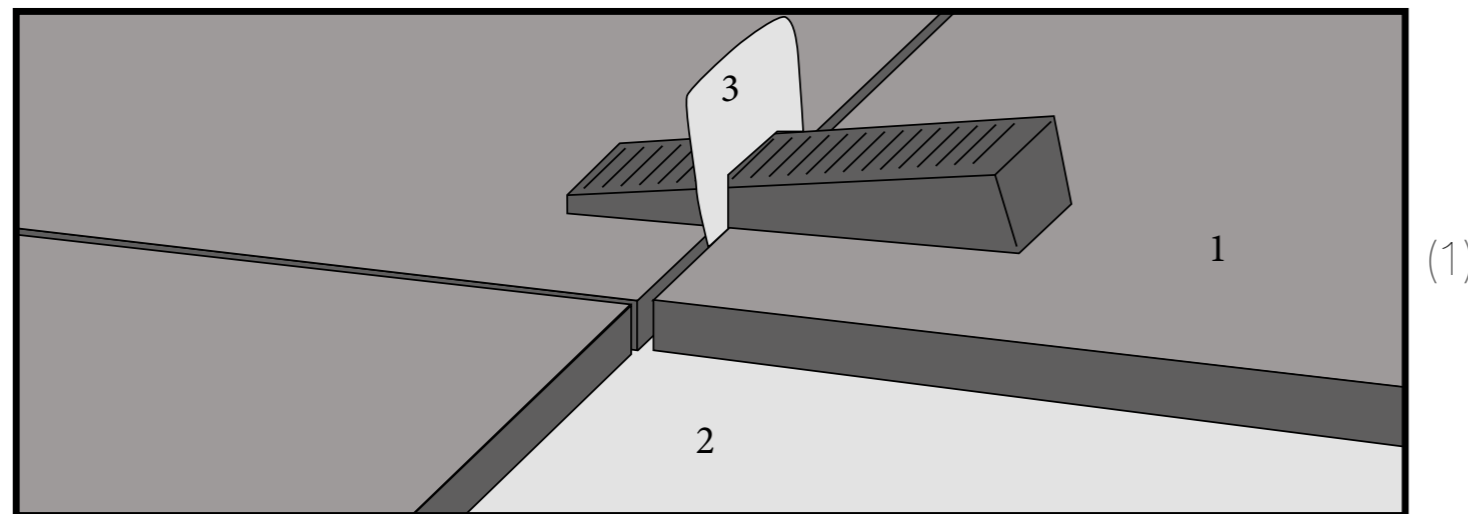

## Sistema de colocación (2)

Para una colocación rápida y fácil se recomienda el uso de sistemas de colocación como el descrito en (2).

Este tipo de sistema ofrece el agarre y seguridad necesario gracias a la utilización de ventosas para garantizar la estabilidad y una estructura metálica que previene el doblado del slab.

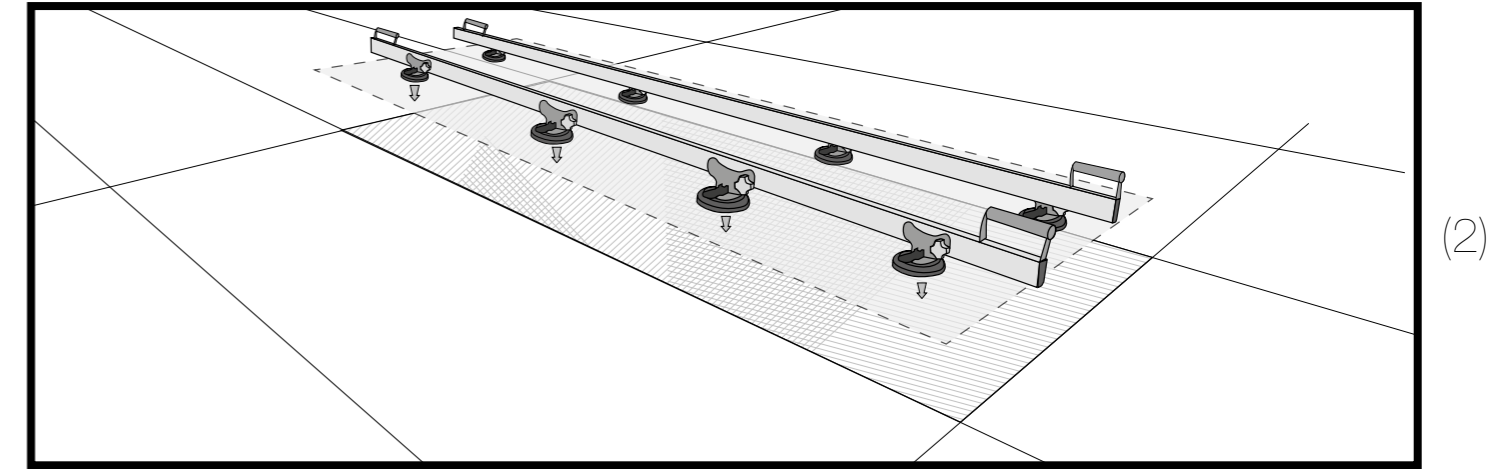

## Jointas de dilatación (3)

Durante el posicionamiento es imperativo el uso de controladores de junta para mantener una junta mínima de 2mm en interiores y 5mm en exteriores. No se recomienda en ningún caso la colocación sin junta, suponiendo esto la anulación de cualquier garantía que haya vigente sobre el producto.

El buen mantenimiento de la junta garantiza la correcta adherencia durante vibraciones, golpes y cambios de temperatura, al permitir cierto juego durante las variaciones dimensionales y planimétricas de un uso adecuado del material.

## Jointas de movimiento (3)

Las juntas de movimiento flexible deben posicionarse en cada uno de los finales de colocación, dejando margen de movimiento suficiente entre los elementos estructurales y las baldosas. Estas juntas deben tener un mínimo de 10mm y respetarse tanto en los extremos como cada 8-14 metros cuadrados de baldosa según el tránsito y climatología.

Además, las juntas estructuras deben ser respetadas en todo momento para evitar un desplazamiento complementario entre el material y los elementos estructurales de la edificación, situación que desfavorece de manera drástica la adherencia del material en el sustrato.

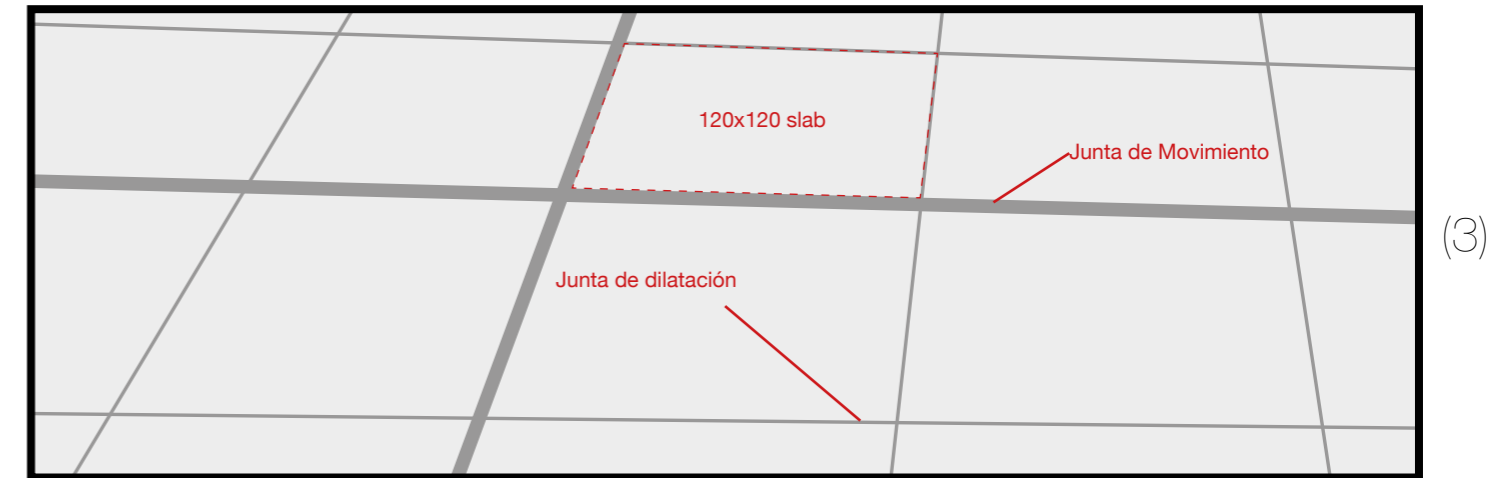

## Rejuntado y limpieza

Se recomienda el uso de material de rejunte cementoso clase CG2 según EN13888 con propiedades hidrófugas y antimoho. El material de rejunte debe ser aplicado después del correcto fraguado del adhesivo y previa limpieza de material adhesivo rebosante,

Una vez aplicado, se requiere una limpieza exhaustiva de la superficie con un detergente ph neutro de base no aceitosa y la posterior absorción del exceso de agua sobrante.

# Cutting

## Manual cutting

Manual cutting requires a cutting guide with a diamond disk carriage. This type of cut can only be straight and, depending on the thickness and length of the cut, cutting may be performed by through cutting with the disk or by scoring and breaking.

In the first case, the material is removed along the entire length of the piece in several passes of a maximum of 4mm effective depth (the disk is introduced in each pass along successive stretches to a maximum of 4mm) until the entire thickness has been removed, thus yielding two separate tile segments.

In this case the disk shall not travel faster than 1.1m/min or have a linear cutting speed above 40m/s.

In the second case, involving scoring and breaking, scoring is performed with tile pliers following the guide and separation takes place by bending the two segments until fracture occurs, using the tile pliers.

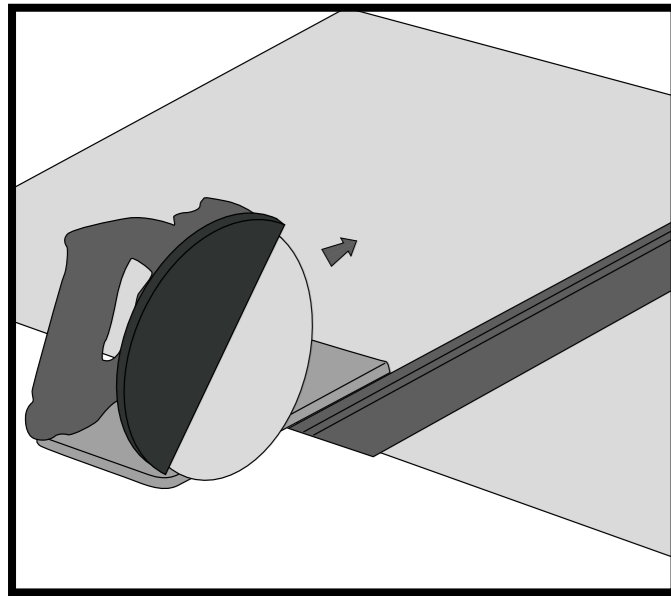

Manual cutting with disk

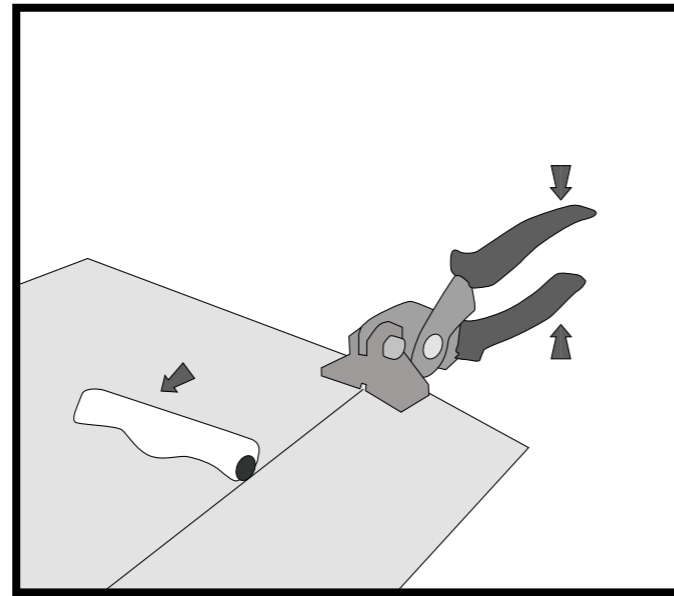

Manual cutting with pliers

## Waterjet cutting

Waterjet cutting should start and end, whenever possible, from the outside of the piece to release stresses, observing a margin of 40mm to the end of the piece once cutting has started to avoid failure.

The angles made by water cutting shall have a minimum fillet radius of 3mm and the curving cuts shall not have a curvature radius below 20mm.

Cutting pressure shall not exceed 4100 bar and cutting speed shall be below 0.8m/min.

## Inner cutting

Manual cutting of internal segments of a slab shall always be done with a disk. Each of the vertices shall be perforated beforehand with a drill providing a minimum fillet radius of 5mm; in no case, shall it be possible to perform a cut at an angle smaller than 180° without a fillet radius owing to the constraints on disk cutting, it also being inadvisable to do so at angles larger than 180°.

To assure slab integrity, each cut out internal segment must be separated from the following by at least 30mm, 50mm being advisable and, in no case, shall any cutting length exceed 40% of the dimension parallel to it.

For example, making an internal box of 20x100cm can only be done longitudinally on a slab of 320x160cm as 100cm does not exceed 40% of 320cm and 20cm does not exceed 40% of 160cm. However, if the internal box were made cross-sectionally, 100cm would correspond to 60% of the slab width (160cm), therefore entailing serious risk of failure.

**Warning!** Performing internal cuts in a slab drastically reduces the slab's resistance to failure by bending.

Any complete cut (from side to side of the piece) conserves the mechanical performance features of the material as there are no internal openings. When an internal opening is made, the internal cross-section decreases and the material may therefore not be able to dissipate the stresses that could arise during use.

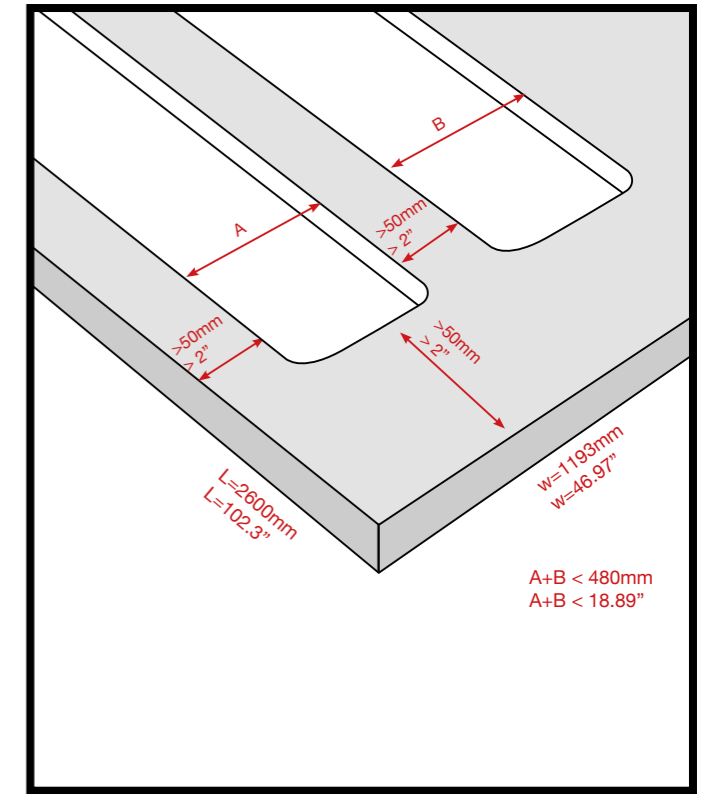
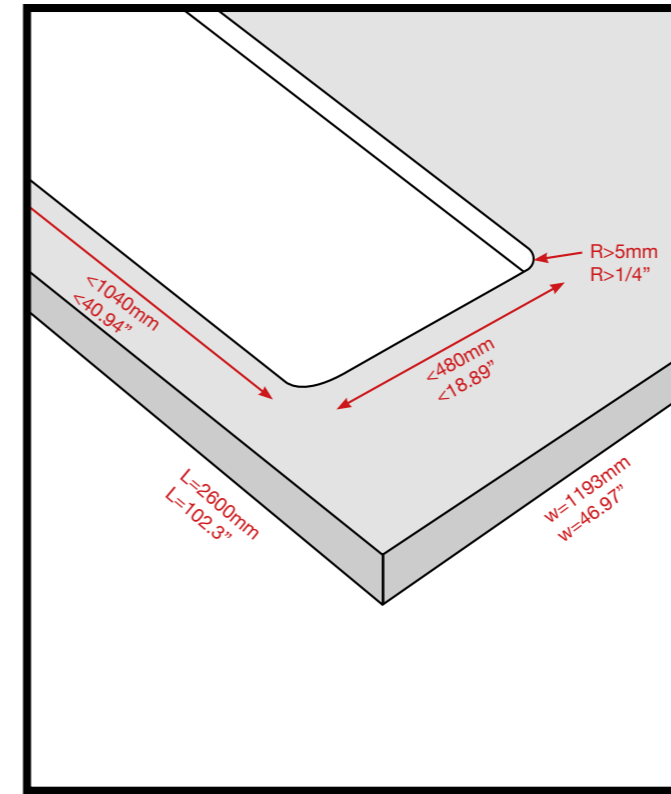

Inner cutting schemes

## Drilling

Drill holes shall be made with a special diamond-tipped drill bit for porcelain tile or with a glass drill bit. There shall be a minimum distance of 5cm between each hole and a minimum distance of 5cm to the piece edges.

**Warning!** Performing internal openings in a slab drastically reduces the slab's resistance to failure by bending.

## Trepanation

Trepanning shall be carried out with a diamond crown for any hole larger than 2cm in diameter (drilling is advisable for smaller diameters). There shall be a minimum distance of 5cm between each opening and a minimum distance of 5mm to the piece edges.

**Warning!** Performing internal openings in a slab drastically reduces the slab's resistance to failure by bending..

## Bevelling

Bevelling shall be performed by abrasion, it being recommended to use disks for standard polished marble or granite. This machining operation shall be done in different stages, starting with the coarsest grit and then reducing grit size down to the fine grit required to obtain the desired polishing finish.

A bevel bit may be of any size provided it has a fillet radius of 0.5mm at its top and bottom edges.

Good bevelling is essential in pieces subject to high stress at their edges, such as worktops, as it reduces stress build-up and minimises the angle of incidence if the material receives a blow.

## Check your material

Slabs are made with comfortable safety margins for the performance of all the machining operations described above. However, Slabs accepts no responsibility for any failure of the material because of bad machining or discovered after such machining, should this occur. Slabs only accepts responsibility for the material if it has any defect before any machining operation is performed on it.

We earnestly urge you, please, to check the material before machining; a material that fails may not only entail a problem during machining but, if any operation is performed on it, it may mask the source of the problem, making it difficult for us to address its occurrence.

# Corte

## Corte manual

Para realizar un corte manual se requiere de una guía de corte con carro de disco diamantado. Este tipo de corte solo puede ser recto y dependiendo del espesor y longitud del corte puede optarse por el corte total con disco o la precisión más rotura.

En el primer caso se realiza el arranque de material a lo largo de toda la longitud de la pieza en diferentes pasadas de un máximo de 4mm de profundidad efectiva (se introduce el disco en cada pasada mediante tramos sucesivos de un máximo de 4mm) hasta que la totalidad del espesor se ha arrancado, quedando los dos tramos de pieza separados.

El disco en este caso no debe superar el 1,1m/min ni una velocidad lineal de corte superior a los 40m/s.

En el segundo caso se realiza un rayado con una tenaza de alicatar siguiendo la guía y la separación se realiza mediante la flexión de las dos partes del material hasta que alcanzan el punto de rotura utilizando la propia tenaza de alicatar.

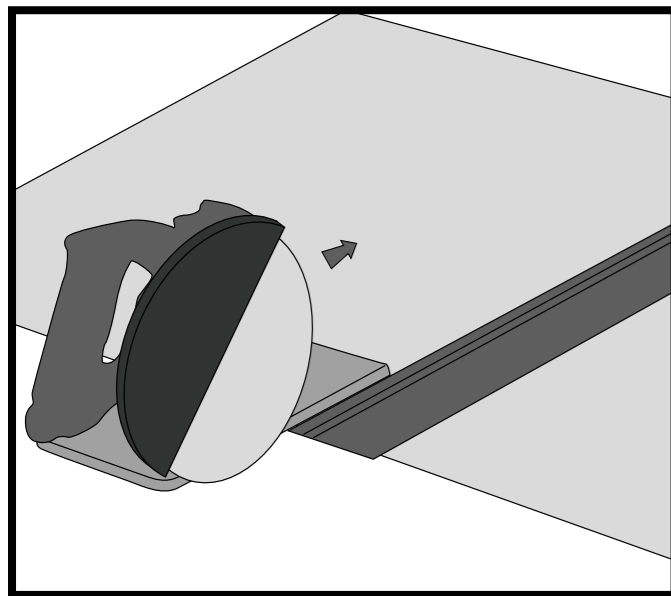

Corte manual con disco

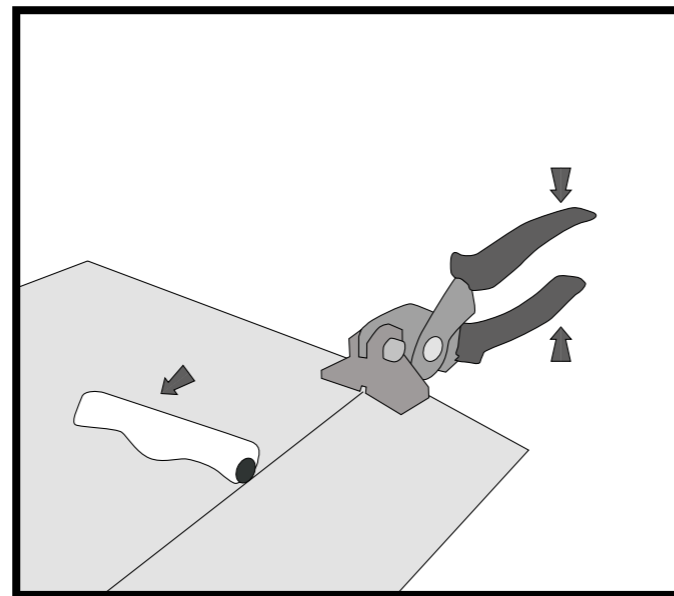

Corte manual con tenaza

## Corte por chorro de agua

El corte por chorro de agua se debe iniciar y finalizar, siempre que sea posible, desde el exterior de la pieza para liberar tensiones y respetando un margen de 40mm hasta el extremo de la pieza una vez empezado el corte para evitar roturas.

Los ángulos realizados con corte de agua deben tener un radio de acuerdo de 3mm mínimo y los cortes curvos no deben tener un radio de curvatura inferior a los 20mm.

La presión de corte no puede superar los 4100 bares y la velocidad de corte tiene que ser inferior a los 0,8m/min.

## Corte interno

Los cortes manuales de segmentos internos de una placa deben realizarse siempre con disco. Cada uno de los vértices debe estar previamente perforado con un taladro que permita un radio de acuerdo de un mínimo de 5mm, en ningún caso se podrá realizar un corte en ángulo inferior a 180° sin radio de acuerdo debido a las limitaciones del corte por disco, siendo también desaconsejable hacerlo en ángulos superiores de 180°.

Para garantizar la integridad de la placa, cada uno de los segmentos internos cortados debe estar separado del siguiente un mínimo de 30mm, 50mm aconsejable, y en ningún caso cualquiera de las longitudes de corte puede superar el 40% de la dimensión a la que le sea paralela.

Ej. Realizar una caja interna de 20x100cm solo se podría realizar de forma longitudinal a una placa de 320x160cm ya que 100cm no supera el 40% de 320cm ni 20cm supera el 40% de 160cm. No obstante si la caja interna se realiza transversalmente, 100cm suponen el 60% del ancho de la placa (160cm) por lo que habría un grave riesgo de rotura.

**¡Precaución!** Realizar cortes internos en una pieza reduce drásticamente la resistencia a rotura por flexión de una placa. Cualquier corte completo (de lado a lado de la pieza) permite conservar las capacidades mecánicas del material al no tener orificios internos. En el momento que se realiza un orificio interno, se disminuye la sección interna y por tanto el material es menos capaz de disipar las tensiones que se pueden generar durante el uso.

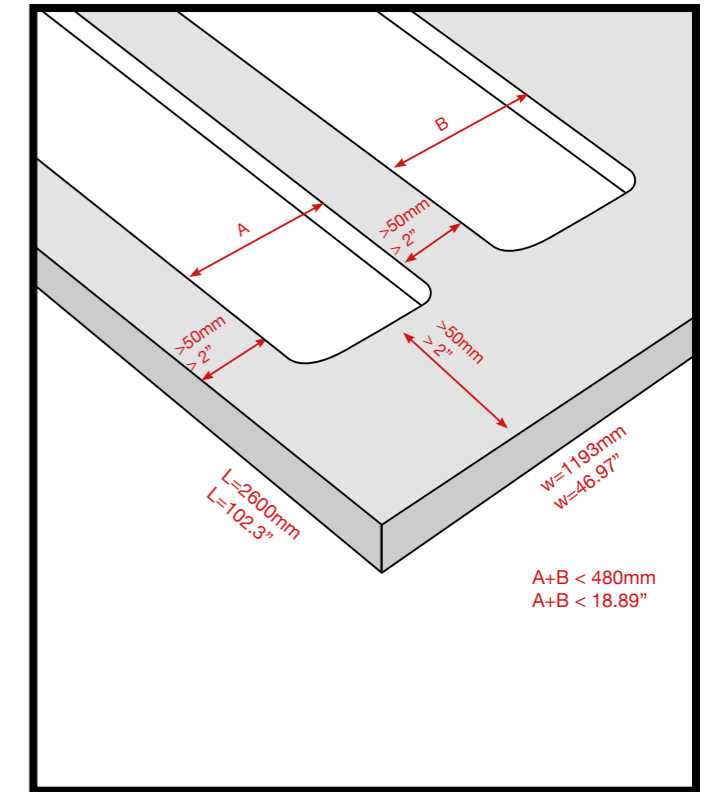
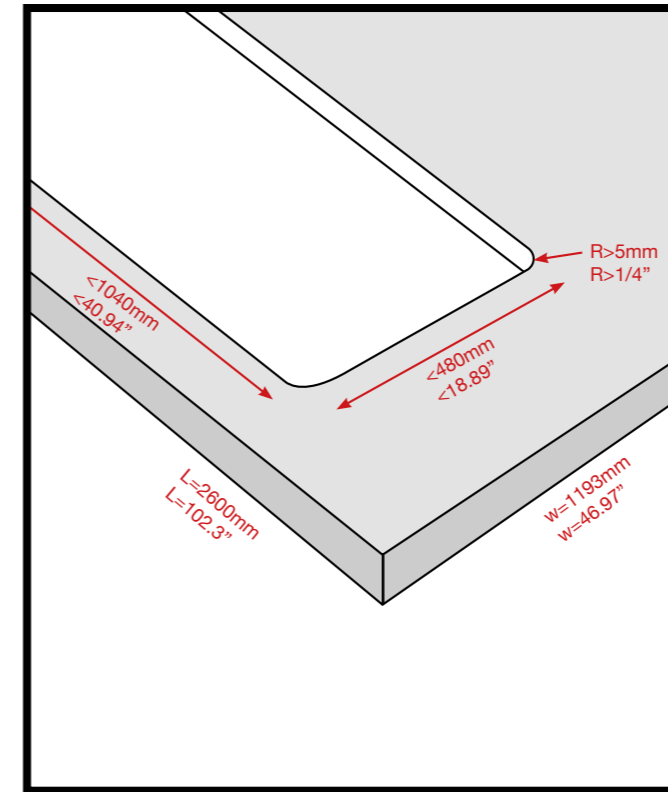

Esquemas de corte interno

## Taladrado

Los orificios con taladro se deben efectuar con una broca de punta diamantada especial para porcelánico o con una broca de vidrio. Entre cada uno de los orificios debe haber una distancia mínima de 5cm y siempre se debe respetar una distancia mínima de 5cm hasta los bordes de la pieza.

**¡Precaución!** Realizar orificios internos en una pieza reduce drásticamente la resistencia a rotura por flexión de una placa.

## Trepanado

Los trepanados se deben efectuar con una corona diamantada para cualquier agujero que supere los 2cm de diámetro (para diámetros inferiores es conveniente taladrar). Entre cada uno de los orificios debe haber una distancia mínima de 5cm y siempre se debe respetar una distancia mínima de 5cm hasta los bordes de la pieza.

**¡Precaución!** Realizar orificios internos en una pieza reduce drásticamente la resistencia a rotura por flexión de una placa.

## Biselado

Los biselados que se quieran hacer deben realizarse por abrasión, recomendando el uso de discos para granito o mármol pulido standar. Este mecanizado se debe realizar en diferentes fases, empezando con el grano más grueso hasta que se reduzca al grano fino para conseguir el tipo de pulido deseado.

Un bisel puede ser de cualquier tamaño siempre que respete un radio de acuerdo de 0,5mm en sus aristas superior e inferior.

Un biselado bien hecho es fundamental en piezas que tengan que sufrir un esfuerzo elevado en sus aristas, como una encimera, ya que reduce las tensiones acumuladas y minimiza el ángulo de incidencia en caso de recibir un golpe el material.

## Comprobación del material

Las baldosas Slabs están preparadas con holgados índices de seguridad para la realización de todos los mecanizados aquí descritos.

No obstante, y si se diese el caso, Slabs no se hace responsable de cualquier falla en el material a causa de un mal mecanizado ni descubierta después de este. Slabs solo se hace responsable del material si este tuviese algún defecto antes de realizar ninguna operación de mecanizado en él.

Le instamos encarecidamente a que lo revise cuidadosamente antes del mecanizado, un material que falla no solo puede suponerle un problema durante el mecanizado, sino que, si le realiza cualquier operación, puede enmascarar la fuente del problema dificultándonos el encontrar la solución a su incidencia.

# Cleaning & maintenance

Eng

The first cleaning "after installation".

The most important cleaning operation is performed immediately after laying the tiles. This involves the complete removal of residues and dirt from the tile placement. An inadequate or late removal of this waste can create a cementitious layer on the tile capable of absorbing all forms of dirt. This may give the impression that the tile gets dirty when the actual problem resides in the surface film of dirt which was not removed immediately after laying.

Once the grouting of the tiles is finished, it is important, while the grout is still wet, to carefully remove any excess material immediately. This can be done using a sponge and plenty of clean water, repeating this as many times as necessary.

Do not perform the cleaning with metal tools, scrapers or abrasive pads. For stubborn stains, clean with alcohol and lukewarm water and rub with a clean cloth. If they do not disappear, check with the relevant technical department.

Once the above mentioned washing is done, another washing should be carried out using basic or alkaline degreasing agents, as acid washing can leave stickiness on the pavement which could help retain dirt. In areas where water is calcareous, it is convenient to dry the surface, in order to prevent the deposition of carbonates which will reduce the surfaces' gleam.

Regular maintenance

Many available cleaning products for general use can be used with our products. For daily cleaning, one can use detergents or degreasing products diluted in warm water, following each product's instructions.

It is important that the cleaner does not have oil, animal fat, or soap base. These components may leave an invisible residue whilst absorbing dirt (lime stratifications detergent or residues). It is also important that the tile receives a thorough rinsing with clean water after the cleaning process is complete.

The low water absorption and high standards met by all porcelain tiles ensure a product which is easy to maintain. Our products do not require the use of sealants or waxes. These superficial coatings can really affect the performance of the tile in a negative manner.

It is important to note that hydrofluoric acid (HF) and derivatives can irreparably damage the tile.

The general steps for regular cleaning of our ceramic products can be summarized as follows:

- Remove any solid or liquid waste from the tile, sweeping with a soft bristle broom or vacuuming.
- Clean up liquid spills as soon as possible with lukewarm water.
- Apply the recommended amount and dilution of the cleaner for the tile (follow the cleaner manufacturer's instructions). The wiper must remain in the tile a minimum period of 5 minutes.
- For unpolished tiles, scrub with a nylon sponge or soft bristle brush. A floor machine equipped with a nylon pad or bristle brush can be used for heavily soiled surfaces. For polished tiles, clean with a nonabrasive cloth.
- Remove the dirty cleaning solution and water with a vacuum cleaner or cloth. Rinse the porcelain tile with clean water and remove again with a vacuum cleaner, mop or towel. It is absolutely essential that all detergent residues are removed completely from the tile. Any remaining detergent that dries on the tiles surface can form a coating that can trap dirt and be very difficult to remove. The tile should be rinsed several times to remove all detergent residues.

During use, the cleaning of the tiles should be similar to window cleaning. Ammonia and even bleach type products can be employed, but both must be diluted in water.

In case of special stains and/or particularly resistant, it is advisable to use specific detergents according to the cleaners' manufacturer. Do not forget that removing any type of stain is easier when it is still fresh.

It is important to always do a pre-test the detergent products result on a small sample of the porcelain.

# Limpieza y mantenimiento

Esp

La primera limpieza "después de la colocación"

La operación de limpieza más importante se lleva a cabo inmediatamente "después de la colocación de la baldosa". Esto implica la eliminación completa de los residuos de lechada y de la suciedad de la colocación de las propias baldosas. Una eliminación inadecuada o tardía de estos residuos puede crear sobre la baldosa una película cementosa capaz de absorber toda forma de suciedad, dando la impresión que se ensucia la baldosa, cuando el problema está en la película superficial de suciedad.

Una vez efectuado el rejuntado de las baldosas, es importante cuando el material de rejuntado todavía está fresco, eliminar el material sobrante cuidadosa e inmediatamente, utilizando para ello una esponja y agua limpia abundante, repitiendo esta operación tantas veces como sea necesario.

No debe realizarse la limpieza del material con espátulas metálicas ni estropajos abrasivos. En el caso de manchas resistentes, limpiar con alcohol y agua caliente y frotar con un paño limpio. Si no desaparecen, consultar con el departamento técnico correspondiente.

Una vez efectuado el lavado mencionado arriba, deberá efectuarse un lavado básico o alcalino utilizando detergentes desengrasantes, ya que el lavado ácido puede dejar una untuosidad sobre el pavimento que podría contribuir a retener la suciedad. En aquellas zonas donde el agua sea calcárea conviene secar la superficie para evitar la deposición de carbonatos que disminuyen el brillo superficial.

Mantenimiento regular

Muchos productos de limpieza de uso general que están disponibles son aceptables para el uso en nuestros productos. Se puede emplear para la limpieza diaria detergentes o desengrasantes diluidos en agua caliente, según indicaciones del envase del limpiador. Es importante que el limpiador no tenga base de aceite, grasa animal, o jabón. Estos componentes pueden dejar un residuo invisible al atrapar la suciedad (estratificaciones de cal de detergente o residuos de suciedad). También es importante que la baldosa reciba un enjuague a fondo con agua limpia después que el proceso de limpieza se haya completado.

La densidad inherente y baja absorción de agua de todos los productos aseguran un producto que es fácil de mantener.

No requieren el uso de selladores o ceras. Estos recubrimientos superficiales pueden realmente afectar negativamente el rendimiento de la baldosa.

Es muy importante tener en cuenta que el ácido Fluorhídrico (HF) y derivados pueden dañar irremediablemente la baldosa.

Los pasos generales de limpieza regular para nuestros productos cerámicos se pueden resumir del siguiente modo:

- Retirar cualquier residuo sólido o líquido de la baldosa, barriendo con una escoba de cerdas suaves o pasar la aspiradora.
- Limpiar los derrames líquidos tan pronto como sea posible.
- Aplicar la cantidad y dilución del limpiador recomendadas para la baldosa (ver indicaciones del fabricante del limpiador). El limpiador deberá permanecer en la baldosa un periodo mínimo de tiempo de 5 minutos.
- Para baldosas sin pulir, frotar con una esponja de nylon o un cepillo de cerdas suaves. Para superficies muy sucias puede usarse una máquina de piso equipado con una almohadilla de nylon o con un cepillo de cerdas. Para baldosas pulidas, limpie con un trapo no abrasivo o un paño.
- Retirar la solución de limpieza sucia y el agua con una aspiradora o un trapo. Enjuague la pieza con agua limpia y retire de nuevo con una aspiradora, fregona, o una toalla. Es absolutamente esencial para todos los residuos de detergente que se eliminen por completo de la baldosa. Cualquier resto de detergente que se seque sobre la baldosa puede formar un recubrimiento que puede atrapar la suciedad y será muy difícil de eliminar. La baldosa debe enjuagarse varias veces para eliminar todos los residuos de detergente.

Durante su uso, la limpieza de la baldosa debe hacerse de forma similar a la limpieza de cristales. Se puede emplear productos de tipo amoniacal e incluso lejía, ambos diluidos en agua.

En caso de manchas particulares y/o especialmente resistentes, es aconsejable usar detergentes específicos según especificaciones del fabricante del limpiador. No hay que olvidar que la eliminación de cualquier tipo de mancha resulta más fácil cuando ésta todavía está fresca.

Es importante hacer siempre una prueba previa antes de usar los productos detergentes.



# Handling / Manipulación

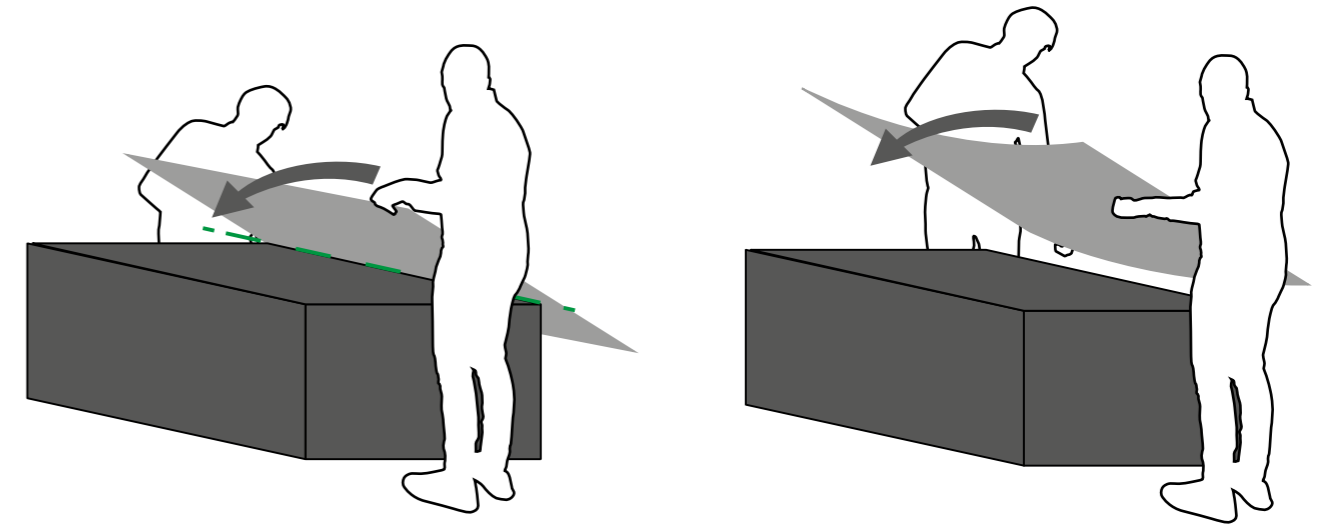
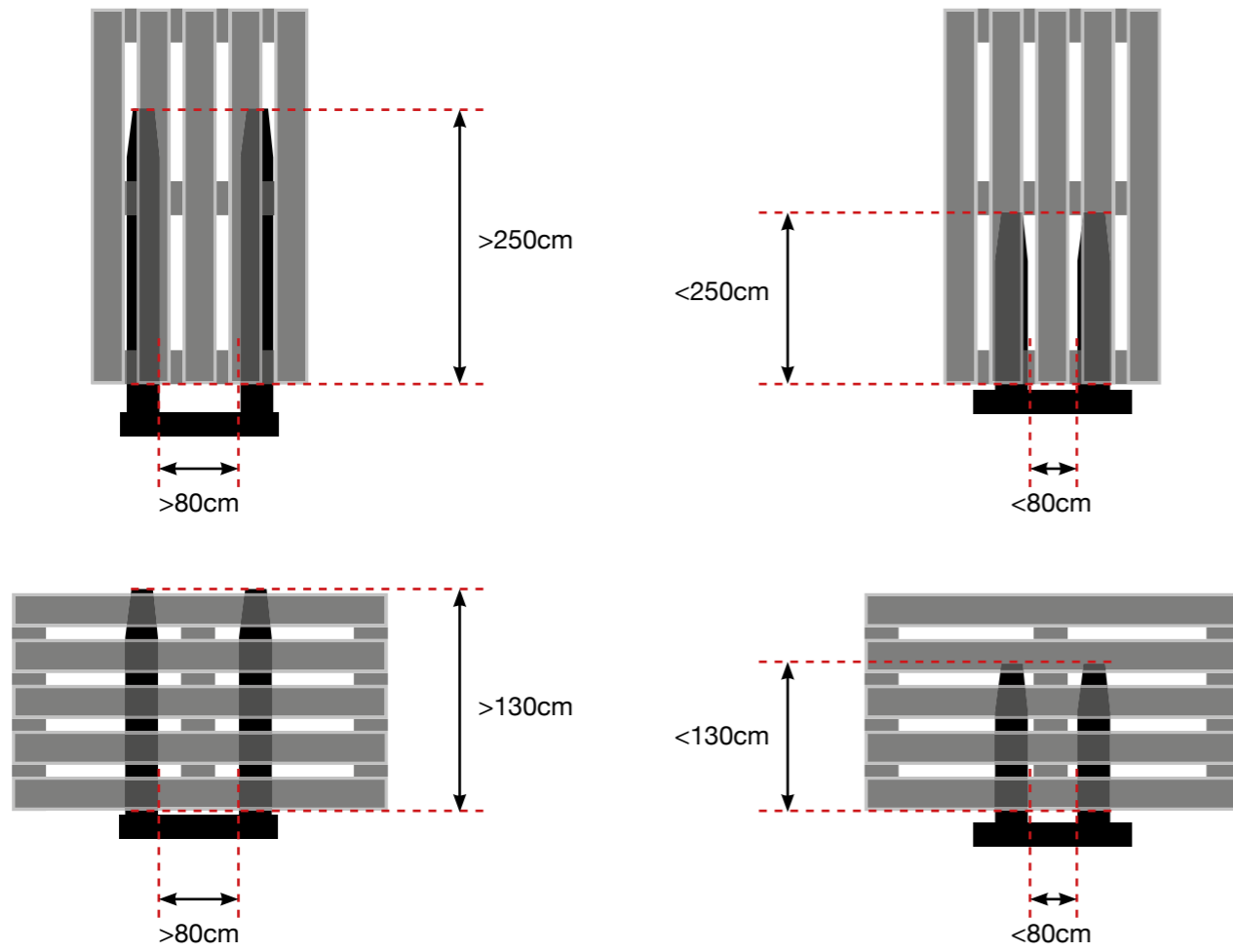
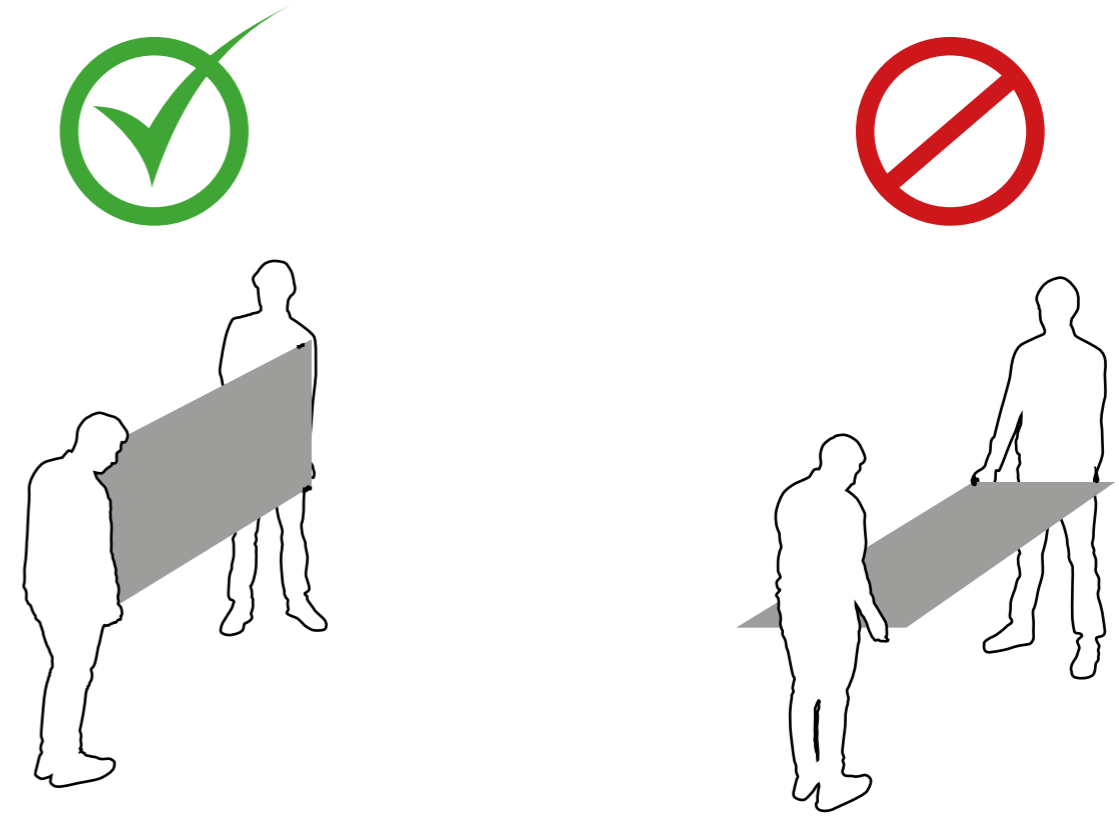
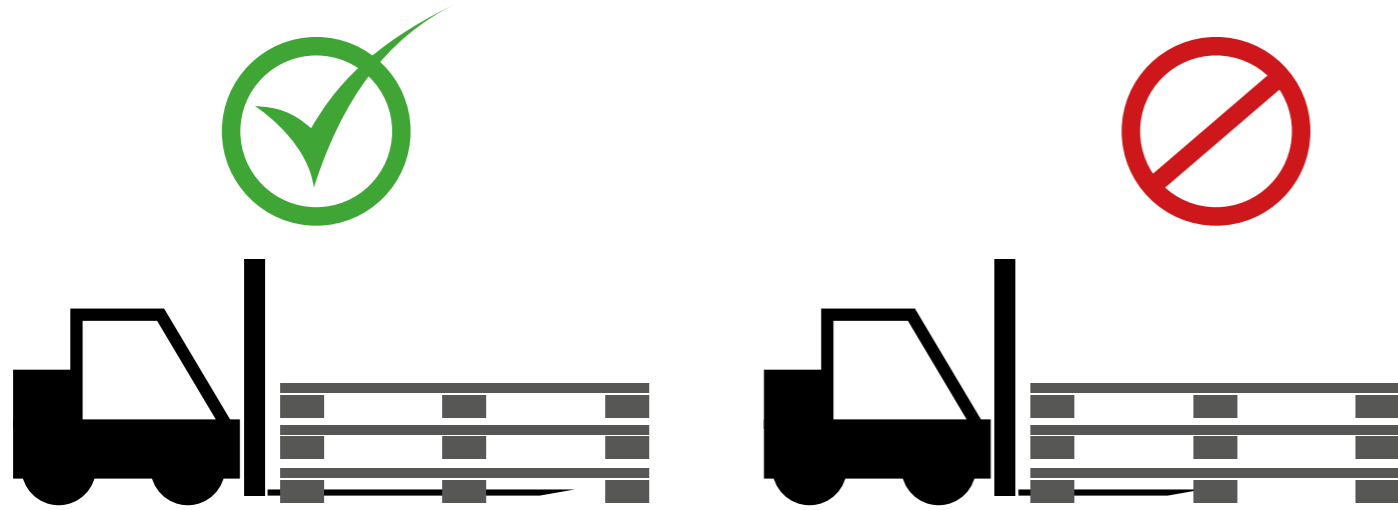

# Packing

8' x 43' truck  
camión de 2,4 x 13 m

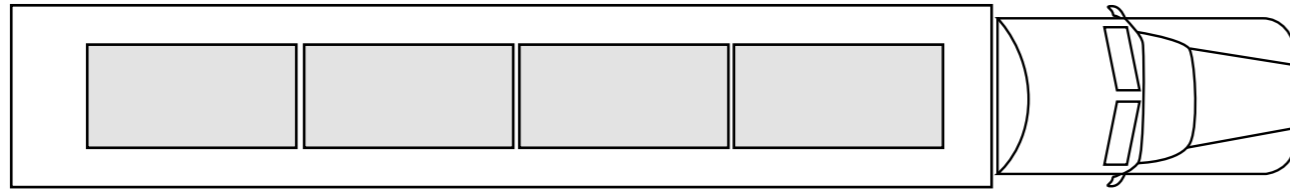

Sizes Formatos	Packing	Nº	m <sup>2</sup>	SF	Total (Kg)
120x260 48"x102"	Wooden crate caja de madera	20	1054,61	11351.75	18518,00 Kg
120x120* 48"x48"	Palet 130x130	27	1226,88	13206.03	21397.77 Kg
30x260* 12"x102"	Palet 75x262	24	1188,10	12788.56	21256,87 Kg

20' container  
container 20 pies

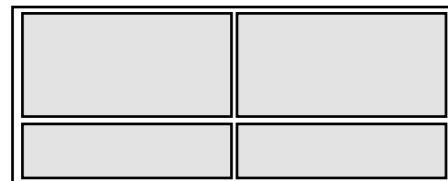

Sizes Formatos	Packing	Nº	m <sup>2</sup>	SF	Total (Kg)
120x260 48"x102"	Wooden crate caja de madera	14	843,69	9081.40	14814,40 Kg
120x120* 48"x48"	Palet 130x130	16	728,70	7843.66	12680,16 Kg
30x260* 12"x102"	Palet 75x262	22	1089,09	11722.85	19485,46 Kg

40' container  
container 40 pies

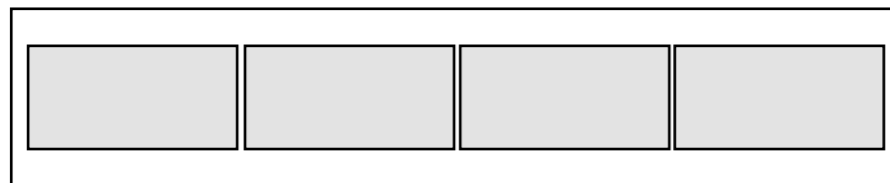

Sizes Formatos	Packing	Nº	m <sup>2</sup>	SF	Total (Kg)
120x260 48"x102"	Wooden crate caja de madera	21	1107,34	11919.34	19443,90 Kg
120x120* 48"x48"	Palet 130x130	25	1138,60	12255.78	19687,77 Kg
30x260* 12"x102"	Palet 75x262	22	1089,09	11722.85	19485,46 Kg

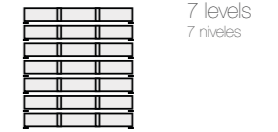

Wooden crate / caja madera  
175 x 340 cm - 69" x 136"

Sizes Formatos	Crate sizes - Medidas de caja Crate weight - Peso de caja	Pieces Piezas	m <sup>2</sup>	SF	Kg/m <sup>2</sup>	Total (Kg)	
160x320 63"x126"	175 x 340 x 38 cm 68.89" x 133.85" x 14.96"	74 Kg	14	71,68	771,56	14,45	1.180 Kg

Wooden crate / caja madera  
140 x 280 cm - 55" x 110"

Sizes Formatos	Crate sizes - Medidas de caja Crate weight - Peso de caja	Pieces Piezas	m <sup>2</sup>	SF	Kg/m <sup>2</sup>	Total (Kg)	
120x260 48"x102"	140 x 280 x 27 cm 55" x 110" x 10"	64 Kg	17	52,73	567.59	16,35	925,90 Kg
60x260 23"x102"	140 x 280 x 27 cm 55" x 110" x 10"	64 Kg	34	52,64	566.64	16,35	924,46 Kg

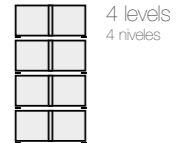

Wooden crate / caja madera  
175 x 183 cm - 69" x 72"

Sizes Formatos	Crate sizes - Medidas de caja Crate weight - Peso de caja	Pieces Piezas	m <sup>2</sup>	SF	Kg/m <sup>2</sup>	Total (Kg)	
160x160 63"x63"	175 x 183 x 41 cm 68.89" x 72.04" x 16.14"	37 Kg	24	61,44	661,34	14,45	975 Kg

Palet  
130 x 130 cm - 51" x 51"

Sizes Formatos	Crate sizes - Medidas de caja Crate weight - Peso de caja	Boxes Cajas	Pieces Piezas	m <sup>2</sup>	SF	Kg/m <sup>2</sup>	Total (Kg)	
120x120* 47"x47"	130 x 130 x 50 cm 51" x 51" x 20"	25 Kg	32	32	45,544	490.23	16,35	792,51 Kg

120x120 packed with carton box.  
120x120 embalado con caja de cartón.

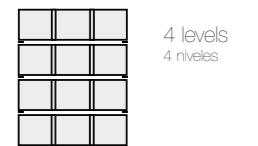

Palet  
90 x 175 cm - 35.43" x 68.89"

Sizes Formatos	Crate sizes - Medidas de caja Crate weight - Peso de caja	Pieces Piezas	m <sup>2</sup>	SF	Kg/m <sup>2</sup>	Total (Kg)	
80x160 31.49"x62.99"	90 x 175 x 50 cm 35.43" x 68.89" x 19.68"	37 Kg	34	43,52	468,44	14,45	700 Kg

Palet  
75 x 262 cm - 30" x 103"

Sizes Formatos	Crate sizes - Medidas de caja Crate weight - Peso de caja	Boxes Cajas	Pieces Piezas	m <sup>2</sup>	SF	Kg/m <sup>2</sup>	Total (Kg)	
30x260* 12"x102"	75 x 262 x 50 cm 30" x 103" x 20"	64 Kg	32	64	49,50	532.86	16,35	885,7 Kg

30x260 packed with carton box.  
30x260 embalado con caja de cartón.

# Ventilated facades

## Fachadas ventiladas

# Steps / Peldaños

STEPS -260 cm  
PELDAÑOS - 260 cm

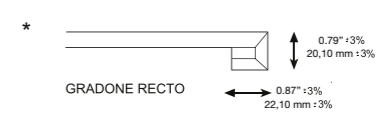
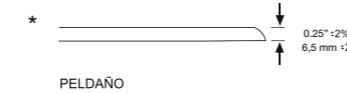
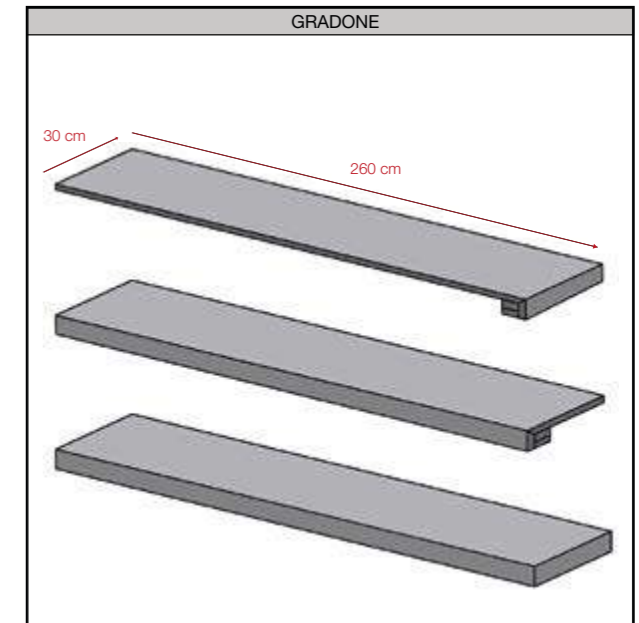
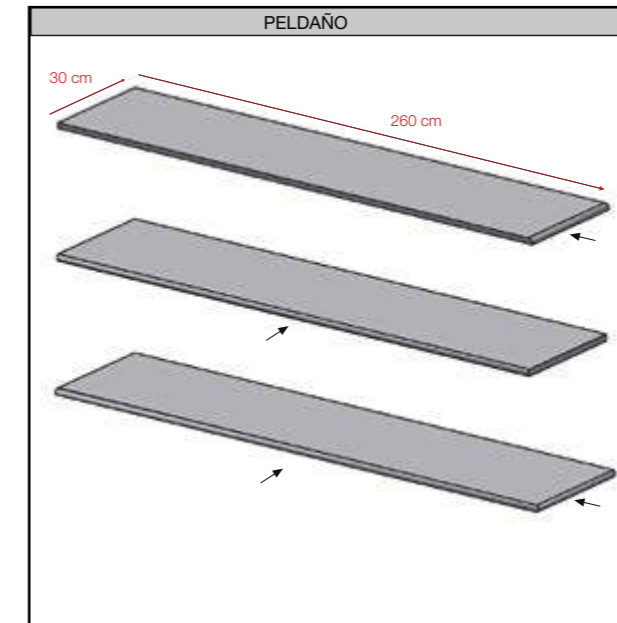

Peldaño 30x260 Polished G-2849  
Peldaño 30x260 Natural G-2839

Gradone 30x260 Polished G-2883  
Gradone 30x260 Natural G-2875

STEPS -130 cm  
PELDAÑOS - 130 cm

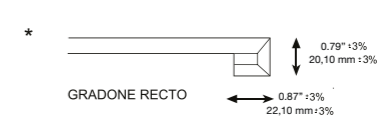
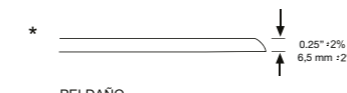
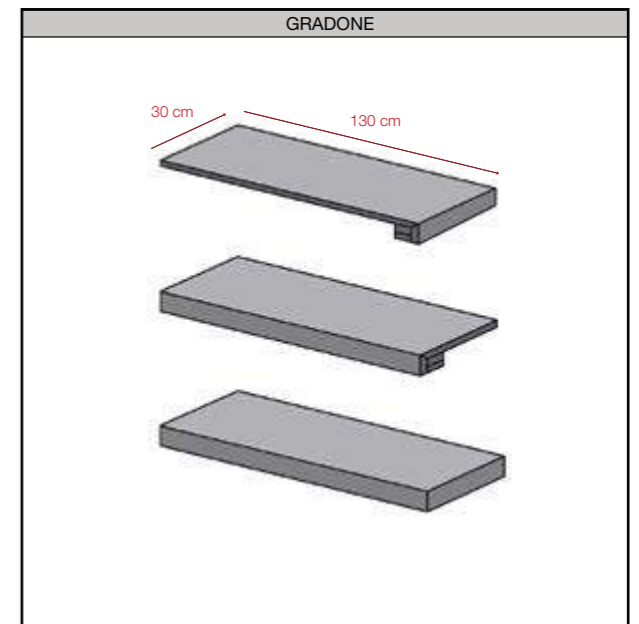
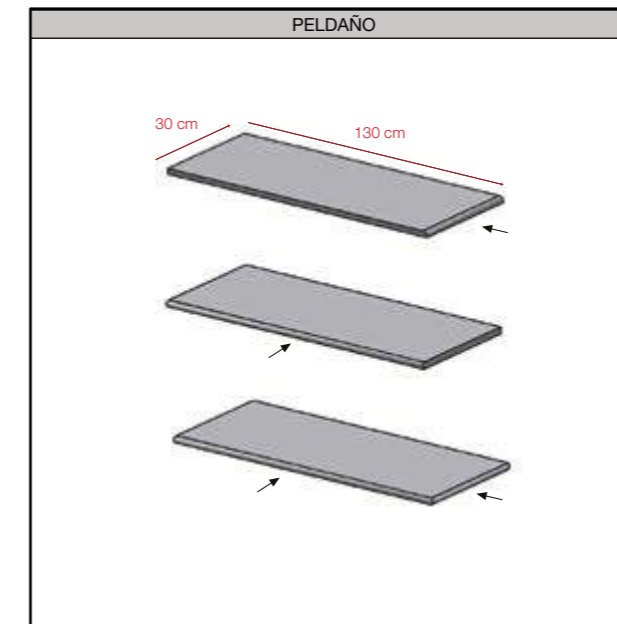

Peldaño 30x130 Polished G-2677  
Peldaño 30x130 Natural G-2651

Gradone 30x130 Polished G-2761  
Gradone 30x130 Natural G-2741

Partes del sistema

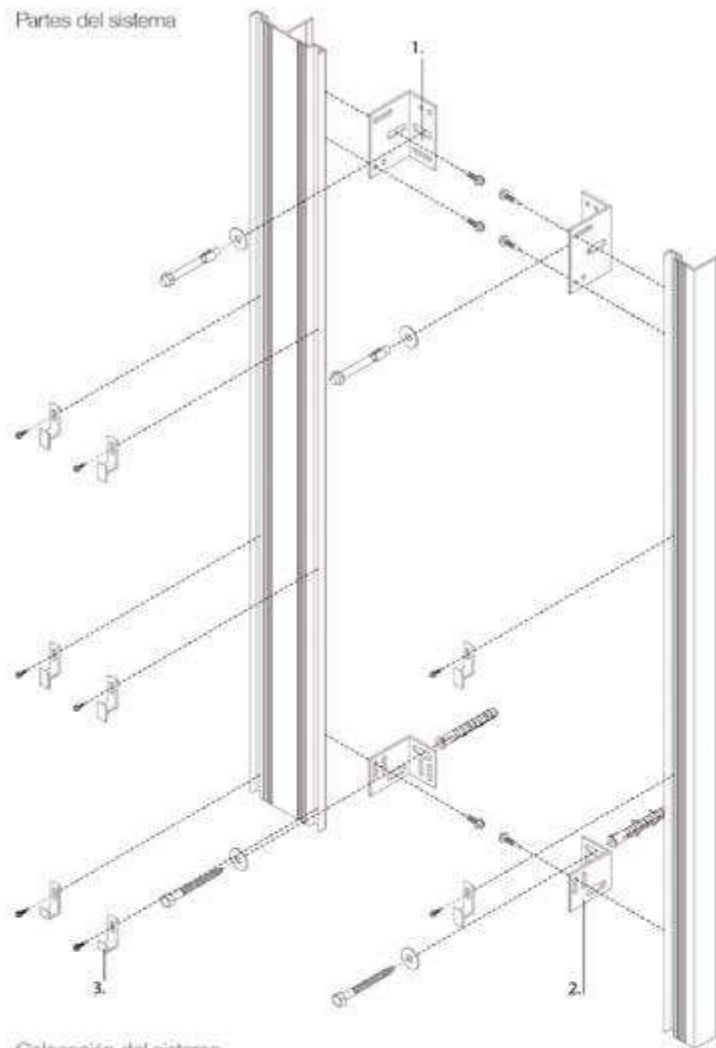

Componentes del sistema



1- Escudras de carga 80-160 mm



2- Escudras de apoyo 80-160 mm



3 - grapas ALFA

Colocación del sistema

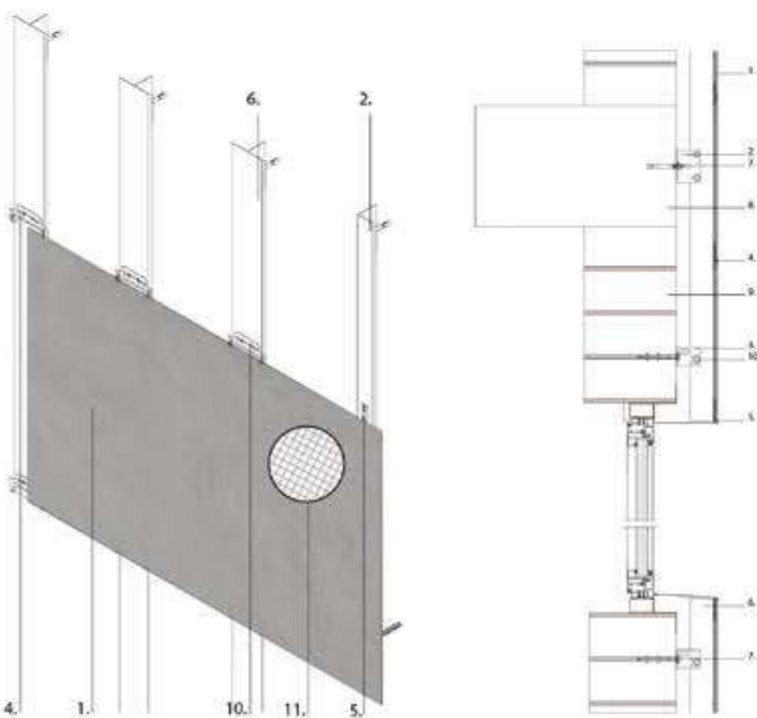

detalle de grapas visible



detalle de grapas invisible



1. Apuñeta Slabs 120x260 x 0,65cm
2. Escudra de carga (80+40) 80x3
3. Escudra de apoyo (80+40) 46x3
4. Grapa Alfa continuación
5. Grapa Alfa inicio-remate
6. Perfil Epsilon T 100 60°
7. Fijación
8. Forjado
9. Perfil Epsilon L 50 60°
10. Autoladrante 5,5 x25
11. Detalle malla

# Product list





## Listado de productos





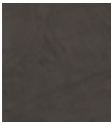
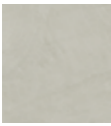
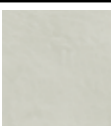

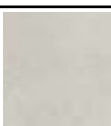
Reference Referencia	Thickness ->	12 mm		6 mm				7 mm					20 mm
	Finish	162x324	160x320	120x260	120x120	60x260	30x260	60x120	60x60	30x60	90x90	45x90	50x100
Borghini white	Polished			G-3467	G-3467	G-3467		G-1442	G-1298				
	Decor Polished								G-1314				
Equinox Anthracite	Natural	-		G-3381	G-3381	G-3381	-	-	-	-			-
	Satin	-		-	-	-	-	G-1298	G-1202	G-1180			-
	Non-Slip	-		-	-	-	-	-	-	G-1208			-
Equinox Grey	Natural	G-3647		G-3381	G-3381	G-3381	-	-	-	-			-
	Satin	-		-	-	-	-	G-1282	G-1180	G1162			-
	Non-Slip	-		-	-	-	-	-	-	G-1194			-
	Solid 2 CM	-		-	-	-	-	-	-	-			G-1258
Equinox White	Natural	-		G-3381	G-3381	G-3381	-	-	-	-			-
	Satin	-		-	-	-	-	G-1282	G-1180	G1162			-
Elegance White Bookmatch	Polished	-		G-3495	-	-	-	-	-	-			-
	Natural			G-3365	G-3365	G-3365					G-1298	G-1202	G-1258
Instinto Taupe	Lappato										G-1330	G-1234	
	Rescato											G-1234	
	Natural			G-3365	G-3365	G-3365					G-1298	G-1202	
Instinto White	Lappato										G-1330	G-1234	
	Rescato											G-1234	
	Natural			G-3365	G-3365	G-3365					G-1298	G-1202	
Junoon Beige	Natural	-		G-3391	-	-	G-3371	-	-	-			G-1258
	Decor Polished	-									G-1314		
Junoon Brown	Natural	-		G-3391	-	-	G-3371	-	-	-			
	Polished												

Reference Referencia	Thickness	12 mm	6 mm						7 mm					20 mm
	Finish	162x324	160x320	120x260	120x120	60x260	30x260	160x160	80x160	60x120	60x60	90x90	45x90	30x60
Junoon Maple	Natural			G-3391			G-3371							G-1258
	Decor Polished													
Pietra Grey	Natural	G-3663		G-3397	G-3397	G-3397								
	Polished	G-3717		G-3459	G-3459	G-3459								
St. Vincent Anthracite	Natural	G-3663		G-3381	G-3381	G-3381	-				-	-	-	-
	Polished	G-3717		G-3451	G-3451	G-3451	-				-	-	-	-
	Solid 2 CM	-		-	-	-	-				-	-	-	G-1258
Statuario White Bookmatch	Natural	G-3701		-	-	-	-				-	-	-	-
	Polished	G-3753		G-3495	-	-	-				-	-	-	-
Statuario White Mix	Natural	-		G-3413	G-3413	G-3413	-				-	-	-	-
	Polished	-		G-3467	G-3467	G-3467	-				-	-	-	-
Tattoo Black	Decor	-		G-3413	G-3413	G-3413	-				G-1372	G-1250	G-1202	-
	Non-Slip	-		-	-	-	-				-	-	G-1232	-
	Solid 2 CM	-		-	-	-	-				-	-	-	G-1258
Tattoo Oxidum	Decor	G-3653		G-3413	G-3413	G-3413	-				G-1372	G-1250	G-1202	
	Natural			G-3365	G-3365	G-3365	-				-	-	-	-
Tattoo White	Satin										G-1372	G-1250	G-1202	-
	Non-Slip	-		-	-	-	-				-	-	G-1232	-
	Polished	-	G-3495				-	G-3495	G-3495	G-1442	G-1298	-	-	-
Ocean Blue	Decor Polished	-									G-1314			
	Natural			G-3459	G-3397	G-3397								
Wild Forest	Polished			G-3459	G-3459	G-3459				G-1442	G-1298			
	Natural													

# Anti-Slip Values

## Valores Anti-Slip

Reference / Referencia	Values / Valores
 Equinox Anthracite	<p>Natural</p> <p>DIN R10 CLASS B DCOF &gt;0,42 PTV &gt;36 CLASE 1</p> <p>Satin</p> <p>DIN R10 DCOF &gt;0,42 CLASE 1</p> <p>Non-Slip</p> <p>DIN R11 CLASS C DCOF &gt;0,42 CLASE 3</p>
 Equinox Grey	<p>Natural</p> <p>DIN R10 CLASS B DCOF &gt;0,42 PTV &gt;36 CLASE 1</p> <p>Satin</p> <p>DIN R10 DCOF &gt;0,42 CLASE 1</p> <p>Non-Slip</p> <p>DIN R11 CLASS C DCOF &gt;0,42 CLASE 3</p> <p>Solid 2 cm</p> <p>DIN R11 CLASS C PTV &gt;36 CLASE 3</p>
 Equinox White	<p>Natural</p> <p>DIN R10 CLASS B DCOF &gt;0,42 PTV &gt;36 CLASE 1</p> <p>Satin</p> <p>DIN R10 DCOF &gt;0,42 CLASE 1</p>
 Instinto taupe	<p>Natural</p> <p>DIN R10 DCOF &gt;0,42 PTV &gt;36 CLASE 1</p> <p>Lappato &amp; Non-Slip</p> <p>DIN R10 DCOF &gt;0,42 PTV &gt;36 CLASE 3</p> <p>Solid 2cm</p> <p>DIN R11 CLASS C PTV &gt;36 CLASE 3</p> <p>Rescato</p> <p>DIN R10 DCOF &gt;0,42 PTV &gt;36 CLASE 1</p>
 Instinto white	<p>Natural</p> <p>DIN R10 DCOF &gt;0,42 CLASE 1 PTV &gt;36</p> <p>Lappato</p> <p>DIN R10 DCOF &gt;0,42 PTV &gt;36 CLASE 3</p> <p>Non-Slip</p> <p>DIN R10 DCOF &gt;0,42 PTV &gt;36 CLASE 3</p> <p>Rescato</p> <p>DIN R10 DCOF &gt;0,42 PTV &gt;36 CLASE 1</p>
 Junoon Beige	<p>Natural</p> <p>DIN R10 DCOF &gt;0,42 PTV &gt;36 CLASE 1</p> <p>Solid 2 cm</p> <p>DIN R11 CLASS C PTV &gt;36 CLASE 3</p>
 Junoon Brown	<p>Natural</p> <p>DIN R10 DCOF &gt;0,42 PTV &gt;36 CLASE 1</p>

Reference / Referencia	Values / Valores
 Junoon Maple	<p>Natural</p> <p>DIN R10 DCOF &gt;0,42 PTV &gt;36 CLASE 1</p> <p>Solid 2 cm</p> <p>DIN R11 CLASS C PTV &gt;36 CLASE 3</p>
 Pietra Grey	<p>Natural</p> <p>DIN R10 DCOF &gt;0,42 PTV &gt;24 CLASE 1</p>
 St. Vincent Anthracite	<p>Natural</p> <p>DIN R10 DCOF &gt;0,42 PTV &gt;36 CLASE 2</p> <p>Solid 2 cm</p> <p>DIN R11 CLASS C PTV &gt;36 CLASE 3</p>
 Statuario Extra White M	<p>Natural</p> <p>DIN R9 DCOF &gt;0,42 PTV &lt;24 CLASE 1</p>
 Tattoo Black	<p>Decor</p> <p>DIN R10 DCOF &gt;0,42 PTV &gt;24 CLASE 1</p> <p>Non-Slip</p> <p>DCOF &gt;0,42 DIN R11 CLASS C CLASE 3</p> <p>Solid 2 cm</p> <p>DIN R11 CLASS C PTV &gt;36 CLASE 3</p>
 Tattoo Oxidum	<p>Decor</p> <p>DIN R10 DCOF &gt;0,42 PTV &gt;24 CLASE 1</p>
 Tattoo White	<p>Natural</p> <p>DIN R10 CLASS B DCOF &gt;0,42 PTV &gt;36 CLASE 1</p> <p>Satin</p> <p>DIN R10 DCOF &gt;0,42 CLASE 1</p> <p>Non-Slip</p> <p>DIN R11 CLASS C DCOF &gt;0,42 CLASE 3</p>

# Specs / Características

Polished / Pulido

TECHNICAL CHARACTERISTICS CARACTERÍSTICAS TÉCNICAS	STANDARD TEST METHOD MÉTODO DE LA NORMA	STANDARD PRESCRIBED VALUES VALOR PRESCRITO POR LA NORMA	SLABS VALUE VALOR SLABS
<b>MEASUREMENTS SURFACE APPEARANCE / DIMENSIONES Y ASPECTO SUPERFICIAL</b>			
<b>NOMINAL THICKNESS/ ESPESOR NOMINAL</b>			6,5mm - 1/4"
<b>LENGTH AND WIDTH / LONGITUD Y ANCHURA</b>	UNE - EN ISO 10545 - 2	+/- 0.6 % max	+/- 0.1 %
<b>THICKNESS / ESPESOR</b>	UNE - EN ISO 10545 - 2	+/- 5.0 % max	+/- 2.0 %
<b>ORTHOGONALITY / ORTOGONALIDAD</b>	UNE - EN ISO 10545 - 2	+/- 0.6 % max	+/- 0.2 %
<b>SURFACE FLATNESS / PLANITUD DE SUPERFICIE</b>	UNE - EN ISO 10545 - 2	+/- 0.5 % max	+/- 0.2 %
<b>PHYSICAL PROPERTIES / PROPIEDADES FÍSICAS</b>			
<b>WATER ABSORPTION / ABSORCIÓN DE AGUA</b>	UNE - EN ISO 10545 - 3	< 0.5 %	<0.1 %
<b>BENDING RESISTANCE / RESISTENCIA A LA FLEXIÓN</b>	UNE - EN ISO 10545 - 4	> 35 N/mm <sup>2</sup>	>50 N/mm <sup>2</sup>
<b>BREAKING STRENGTH / FUERZA DE ROTURA</b>	UNE - EN ISO 10545 - 4	> 700 N	>2000 N
<b>RESISTANCE TO DEEP ABRASION / RESISTENCIA A LA ABRASIÓN PROFUNDA</b>	UNE - EN ISO 10545 - 6	< 175 mm <sup>3</sup>	<170mm <sup>3</sup>
<b>TEMPERATURE SHOCK RESISTANCE / RESISTENCIA AL CHOQUE TERMICO</b>	UNE - EN ISO 10545 - 9	NO SURFACE DEFECTS SHOULD BE VISIBLE NO DEBE PRESENTAR DEFECTOS O ROTURAS VISIBLES	Resistant / Resistente
<b>RESISTANCE TO COLD / RESISTENCIA A LA HELADA</b>	UNE - EN ISO 10545 - 12	NO SURFACE DEFECTS OR CRACKS SHOULD BE VISIBLE NO DEBE PRESENTAR DEFECTOS VISIBLES	ANTI-ICE / Antihielo
<b>ANTI-SLIP / ANTIDESLIZAMIENTO</b>	DIN 51130	-	-
	DIN 51097	-	-
	UNE - ENV 12633	-	-
	ASTM C 1028-96	-	-
	BS EN 13036-4	-	-
<b>COLOUR RESISTANCE TO LIGHT / RESISTENCIA DEL COLOR A LA LUZ</b>	DIN 51094	THERE SHOULD BE NO COLOUR VARIATIONS NO DEBE PRESENTAR VARIACIONES DE COLOR	NO ALTERATIONS
<b>CHEMICAL PROPERTIES / PROPIEDADES QUÍMICAS</b>			
<b>CHEMICAL RESISTANCE / RESISTENCIA QUÍMICA</b>	UNE - EN ISO 10545 - 13	RESISTANCE TO CHEMICAL PRODUCTS	Min. ULB /UHB
<b>RESISTANCE TO STAINING / RESISTENCIA A LAS MANCHAS</b>	UNE - EN ISO 10545 - 14	>3 RESISTENCIA A PRODUCTOS QUÍMICOS	4

## General information / Información general

### Recommended information

All products receive a protective coating to prevent possible attacks during their placement in the implementation process at work. This protection should be completely removed resulting in clean material. Please consult our commercial network if you have any questions regarding recommended cleaning for our products.

### Información recomendada

Todos los productos llevan una aplicación protectora para evitar posibles agresiones durante su colocación en el proceso de ejecución de la obra. Esta aplicación debe eliminarse completamente para conseguir una limpieza óptima del material. Consulte con nuestra red comercial cualquier duda acerca de las recomendaciones de limpieza de nuestro producto.

### Information reommandée

Tous nos produits viennent avec une pellicule protectrice pour éviter les éventuelles agressions lors de la pose du matériel sur chantier. Cette protection doit être complètement éliminée pour obtenir un nettoyage optimum des carreaux. Veuillez consulter auprès de notre réseau commercial pour toute demande sur les recommandations de nettoyage de nos produits.

### Empfohlene information

Alle Produkte sind mit einer Schutzschicht versehen um mögliche Angriffe während der Verlegung und Verarbeitung zu vermeiden. Diese Schutzschicht muss vollständig entfernt werden um eine optimale Reinigung des Materials zu erzielen. Bei Fragen zur Reinigungsempfehlung unserer Produkte wenden sie sich bitte an unser Händlernetz.

# Specs / Características

Natural

TECHNICAL CHARACTERISTICS CARACTERÍSTICAS TÉCNICAS	STANDARD TEST METHOD MÉTODO DE LA NORMA	STANDARD PRESCRIBED VALUES VALOR PRESCRITO POR LA NORMA	SLABS VALUE VALOR SLABS
<b>MEASUREMENTS SURFACE APPEARANCE / DIMENSIONES Y ASPECTO SUPERFICIAL</b>			
<b>NOMINAL THICKNESS/ ESPESOR NOMINAL</b>			6,5mm - 1/4"
<b>LENGTH AND WIDTH / LONGITUD Y ANCHURA</b>	UNE - EN ISO 10545 - 2	+/- 0.6 % max	+/- 0.1 %
<b>THICKNESS / ESPESOR</b>	UNE - EN ISO 10545 - 2	+/- 5.0 % max	+/- 2.0 %
<b>ORTHOGONALITY / ORTOGONALIDAD</b>	UNE - EN ISO 10545 - 2	+/- 0.6 % max	+/- 0.2 %
<b>SURFACE FLATNESS / PLANITUD DE SUPERFICIE</b>	UNE - EN ISO 10545 - 2	+/- 0.5 % max	+/- 0.2 %
<b>PHYSICAL PROPERTIES / PROPIEDADES FÍSICAS</b>			
<b>WATER ABSORPTION / ABSORCIÓN DE AGUA</b>	UNE - EN ISO 10545 - 3	< 0.5 %	<0.1 %
<b>BENDING RESISTANCE / RESISTENCIA A LA FLEXIÓN</b>	UNE - EN ISO 10545 - 4	> 35 N/mm <sup>2</sup>	>50 N/mm <sup>2</sup>
<b>BREAKING STRENGTH / FUERZA DE ROTURA</b>	UNE - EN ISO 10545 - 4	> 700 N	>2000 N
<b>RESISTANCE TO DEEP ABRASION / RESISTENCIA A LA ABRASIÓN PROFUNDA</b>	UNE - EN ISO 10545 - 6	< 175 mm <sup>3</sup>	<170mm <sup>3</sup>
<b>TEMPERATURE SHOCK RESISTANCE / RESISTENCIA AL CHOQUE TERMICO</b>	UNE - EN ISO 10545 - 9	NO SURFACE DEFECTS SHOULD BE VISIBLE NO DEBE PRESENTAR DEFECTOS O ROTURAS VISIBLES	Resistant / Resistente
<b>RESISTANCE TO COLD / RESISTENCIA A LA HELADA</b>	UNE - EN ISO 10545 - 12	NO SURFACE DEFECTS OR CRACKS SHOULD BE VISIBLE NO DEBE PRESENTAR DEFECTOS VISIBLES	ANTI-ICE / Antihielo
<b>ANTI-SLIP / ANTIDESLIZAMIENTO</b>	DIN 51130	-	See table / Ver tabla*
	DIN 51097	-	-
	UNE - ENV 12633	-	-
	ANSI A137.1 S-9-6-1	-	>0,42
	BS EN 13036-4	-	-
<b>COLOUR RESISTANCE TO LIGHT / RESISTENCIA DEL COLOR A LA LUZ</b>	DIN 51094	THERE SHOULD BE NO COLOUR VARIATIONS NO DEBE PRESENTAR VARIACIONES DE COLOR	NO ALTERATIONS
<b>CHEMICAL PROPERTIES / PROPIEDADES QUÍMICAS</b>			
<b>CHEMICAL RESISTANCE / RESISTENCIA QUÍMICA</b>	UNE - EN ISO 10545 - 13	RESISTANCE TO CHEMICAL PRODUCTS	Min. ULB /UHB
<b>RESISTANCE TO STAINING / RESISTENCIA A LAS MANCHAS</b>	UNE - EN ISO 10545 - 14	>3 RESISTENCIA A PRODUCTOS QUÍMICOS	4

\*See Anti-Slip Values table - pages 114-115

\*Ver tabla de valores Anti-Slip - páginas 114-115

Tests for polished finish characteristics done in Statuario White Polished 120x260. Average test result value on March 2017. Consult specific product test result value before supplying.

Pruebas para las características del acabado pulido realizadas sobre el producto Statuario White Polished 120x260. Valor de media a fecha de Marzo 2017. Consultar valor de un producto específico antes del suministro.

Tests for natural finish characteristics done in Tattoo Oxidum Decor 120x260. Average test result value on March 2017. Consult specific product test result value before supplying.

Pruebas para las características del acabado natural realizadas sobre el producto Tattoo Oxidum Decor 120x260. Valor de media a fecha de Marzo 2017. Consultar valor de un producto específico antes del suministro.

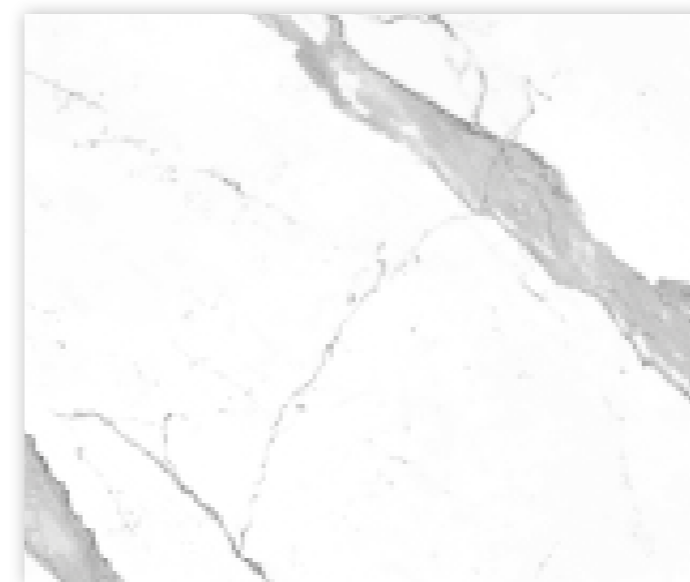

Statuario White Polished



Tattoo Oxidum Decor



slabs

**APAVISA**

[www.apavisaslabs.com](http://www.apavisaslabs.com)

Ctra. Castellón – San Juan de Moró, hm.7,5 - 12130 SAN JUAN DE MORÓ (Castellón) Spain  
Tel. +34 964 701 120 - Export Fax +34 964 701 067 - Fax Nacional 964 701 195 - [info@apavisa.com](mailto:info@apavisa.com)